



# **GENERIC**



## **Race 50**

*DESIGN*  **AUSTRIA**

# **Service Manual**



**SCANDINAVIAN MACHINERY IMPORT ApS**

**Holtvej 8-10, Høruphav, 6470 Sydals**

**Telefon: +45 73 15 11 00**

**Fax: +45 73 15 11 01**

**E-mail: [info@scanmi.dk](mailto:info@scanmi.dk) · [www.scanmi.dk](http://www.scanmi.dk)**

**CVR: 27 73 31 07**

**November 2010**

# **User's operation and maintenance manual for double-wheel motorcycle RACE 50**



# Zhejiang Qianjiang Motorcycle Co., Ltd.

## Contents

Contents	2
Preface	4
Documents to be prepared .....	5
Inspection/adjustment .....	6
Inspection and Service of Electrical System	63
I. Battery/ Charging system	67
1.1 Preparation data .....	53
1.2 Fault diagnosis .....	53
1.3 Battery .....	71
1.4 Charging system .....	72
1.5 Voltage and current regulator .....	73
1.6 Charge coil of the alternator .....	74
1.7 Disassembly of alternator .....	74
II. Ignition system	61
2.1 Preparation data .....	61
2.2 Fault diagnosis .....	79
2.3 Ignition system inspection .....	83
2.4 CDI group .....	84
2.5 Ignition coil .....	86
2.6 Trigger .....	86
III. Startup system	90
3.1 Preparation data .....	91
3.2 Fault diagnosis .....	93
3.3 Start electric machinery .....	93
3.4 Start relay .....	96
IV. Bulbs/ switch/instrument	73
4.1 Preparation data .....	99
4.2 Fault diagnosis .....	99

4.3 Replace the head light bulb.....	99
4.4 Replace bulb of the front turning light.....	100
4.5 Disassembly/replace the bulb of the taillight and rear-right turning light .....	100
4.6 Instrument.....	101
4.7 Main switch .....	101
4.8 Horn.....	102
4.9 Handle switch .....	102
Inspection and Service of Chassis	103
V. Brake	80
5.1 Maintenance instruction.....	107
5.2 Fault diagnosis .....	108
5.3 Front hydraulic brake.....	108
5.4 Rear drum brake .....	110
VI . Body cover	86
VII. Front wheel/ front suspension	90
7.1 Preparation data .....	119
7.2 Fault diagnosis.....	119
7.3 Front wheel .....	120
7.4 Steering bar.....	123
7.5 Front fork.....	124
VIII. Rear wheel/rear suspension	97
8.1 Preparation data .....	128
8.2 Fault diagnosis.....	128
8.3 Real wheel .....	129
8.4Rear shock absorber.....	130
IX. Fuel tank/seat mat	136
9.1 Preparation data .....	136
9.2 Fault diagnosis.....	136
9.3 Fuel tank/seat mat.....	137
Inspection and maintenance of engine	139
X. Lubrication system	107
10.1 Preparation data .....	143
10.2 Fault diagnosis.....	144
10.3 Oil pump.....	144
XI. Carburetor	111
11.1 Preparation data .....	149
11.2 Fault diagnosis.....	150
11.3 Disassembly of carburetor .....	150
11.4 Installation & adjustment.....	155
XII. Cylinder cover	116
12.1 Preparation data .....	157
12.2 Fault diagnosis.....	157
12.3 Cylinder head.....	157
12.4 Examination on cylinder head .....	159
12.5 Cylinder head installation.....	159
XIII. Air cylinder/piston	120

13.1 Preparation data .....	162
13.2 Fault diagnosis .....	163
13.3 Cylinder body .....	163
13.4 Piston .....	165
13.5 Installation of piston .....	170
XIV. Drive disk/Clutch/Driven Wheel / Foot start mechanism	174
14.1 Preparation data .....	174
14.2 Fault diagnosis .....	174
14.3 Left crankcase cover .....	175
14.4 Drive disk.....	175
14.5 Clutch/driven wheel.....	178
14.6 Disassemble the clutch and the driven wheel .....	180
14.7 Installation .....	186
14.8 Foot start mechanism .....	186
XV. Decelerator	137
15.1 Preparation data .....	189
15.2 Fault diagnosis .....	189
15.3 Gear Case.....	189
15.4 Installation .....	191
XVI. Crankcase	140
16.1 Preparation data .....	194
16.2 Fault diagnosis .....	195
16.3 Crankcase.....	195
16.4 Installation .....	199
Exhaust emission system inspection and maintenance	144
XVII. Exhaust emission and control system	145
17.1 Warranty of Exhaust emission and control system.....	201
17.2 Regular maintenance guideline.....	202
17.3 Mechanical function of the exhaust control system.....	203
17.4 Catalyst converter system .....	205
17.5 Countermeasure of idle speed emission exceeding specified value ( Two-stroke ) .....	206

## **Preface**

This Manual explains the maintenance of Qianjiang RACE 50.

The documents to be prepared are the maintenance manual and all the operations are included in, please read the manual prior to operation.

Inspection and Adjustment explains the gist of inspection and adjustment; the maintenance of safety of vehicle and the performance of each part should come into force since regular inspection.

After Chapter I is the explanation of the gist of disassembly, assembly and inspection of engine, entire vehicle and electric fittings.

There are exploded view, system diagram, maintenance, fault diagnosis and explanation before each chapter.

Notice :

There is no prior individual notification on the alteration of mode or structure of motorcycle and the actual product shall prevail if there is discrepancy between the photos, pictures or explanation contained in this Manual and the actual product.

**Zhejiang Qianjiang Motorcycle Co., Ltd.**

## Documents to be prepared

General safety

Maintenance regulation

Specification sheet

Troubleshooting

General safety

Carbon monoxide

If the engine must be activated, make sure that the workplace is well ventilated. The engine can not be running in a confined place.

**Attention**

The exhaust contains toxic gas, carbon monoxide, which can numb people and may result in death.

The engine should be started in an open area and the exhaust scavenging system should be applied if the engine has to be started in a closed area.

**Gasoline**

The operation should be made in a ventilated area and smoking or lighting fires should be strictly forbidden in working space or the place stored gasoline.

## Battery

Battery could give off explosive gases, so, keep it away from incineration area or open flame or where smoking is permissible. When charging, keep it well-ventilated.

Battery contains sulphuric acid (electrolyte) which could result in burn if contacting your skin or eye, so, wear protective clothing and faceshield.

-If electrolyte spatters on your skin, use fresh water to flush immediately.

-If electrolyte spatters in your eye, use fresh water to flush for more than 15 minutes and see a doctor immediately.

Electrolyte is toxic. In case you drink some electrolyte inadvertently, drink a large volume of fresh water, milk and milk of magnesia (a kind of laxative antiacid) or vegetable oil and see a doctor immediately. Keep it at a place where is beyond reach of children.

## Maintenance regulation

As maintaining this vehicle, the instrument of metric system should be applied as possible for the reason that the application of incorrect instrument may damage this vehicle.

Before dismantling from or frame cover of vehicle to maintain the dirt of parts or external subassembly should be purged in order to prevent that falling into engine , chasis or braking system.

After dismantling and before measuring attrition value, please clean parts and purge it with compressor.

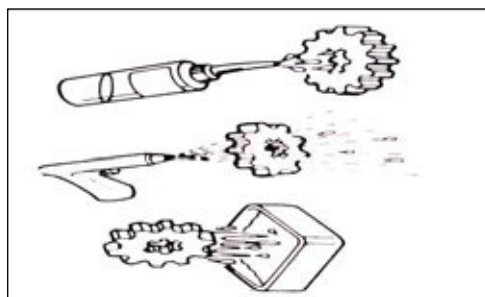

The rubber parts will be deteriorated due to aging which is prone to be damaged by solvent or oil and it should be inspected (if necessary, it should be replaced) before reinstallation.

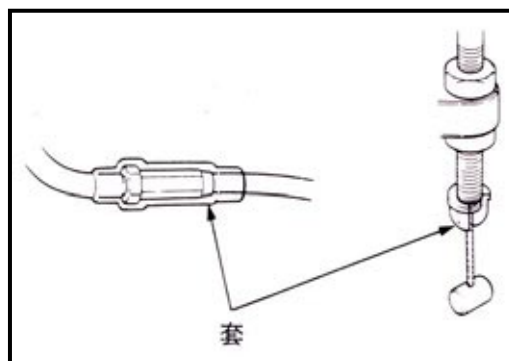

Sleeve



Loosen the parts with multiple assemblies that should be made from outside to inside and started from small one.

The complicated assembly, transmission case, for instance, should be stored according to proper assembly sequence in order to facilitate the assembly in the future.

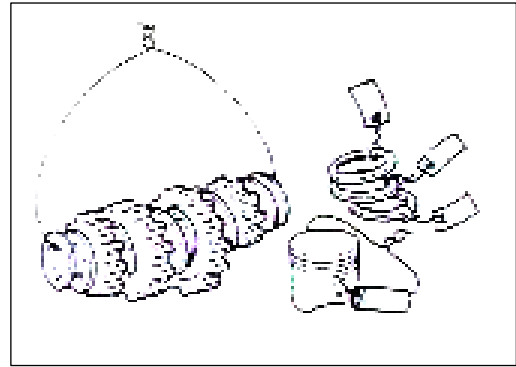

For the important assembly position, it should be given special attention before dismantling. The parts out of use should be replaced before dismantling in time.

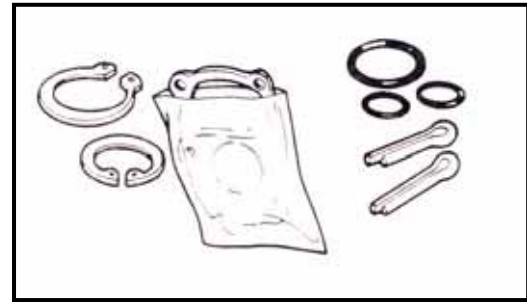

The length of bolts to assemblies and frame cover are different which should be installed in correct position and the bolts may be placed in the hole to find out whether they are suitable if they are mixed.

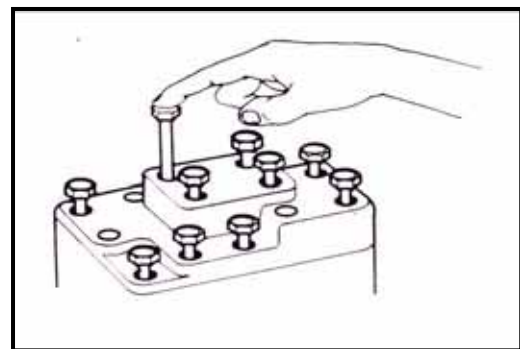

For the installation of oil seal, the grease should be filled in oil seal groove; as installing oil seal, it should check the smoothness of oil seal whether it will likely damage the oil seal.

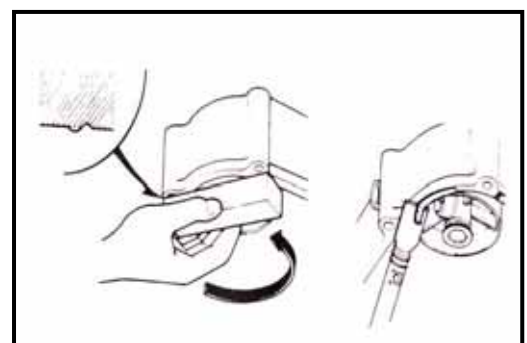

For the installation of rubber hose (fuel, vacuum or coolant), the ends of which should plug into the bottom of the joint in order to ensure that there is enough space for hose clamp to clamp the joint. The rubber or plastic soldering cup should restore its

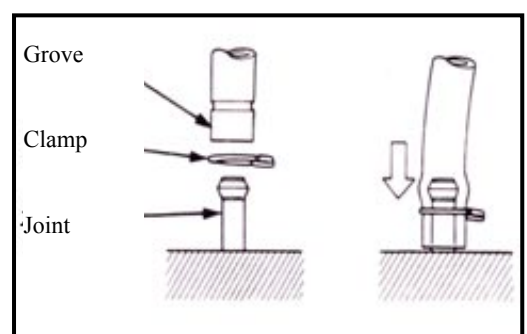

original design position.

As dismantling ball bearing, please use the tool to withstand one or two (internal and external) bearing runners. If the strength is only applied onto a rolling ring (no matter internal or external), the bearing may be damaged as dismantling and has to be replaced.

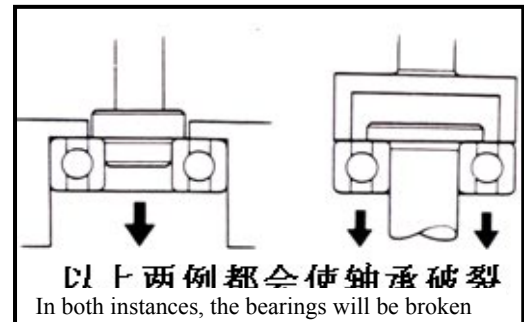

Loose cable is a hidden trouble to electrical safety. After clamped, check each cable to ensure electrical safety;

It is not allowed to leave any wire clip bending towards bonding points;

Bind each cable to its designated position;

It is not allowed to lay a cable to end or a sharp corner on frame;

It is not allowed to lay a cable to end of a bolt or screw;

When laying a cable, keep it away from any heat source or any place where may bite it when it is moving;

When laying a cable along a handle, avoid it being strained too tightly or loosely and it can not interfere with any adjacent part at any turning point;

All cables should be laid smoothly without twist or knot;

Before butt-jointing a connector, check if its sheath has been damaged and if it is overstretched;

If a cable is at a sharp corner or outer corner, use tape or hose to protect it;

After a cable is repaired, use tape to bind it securely;

Keep all control cables from bend or twist because dumb control will result in case any control cable is damaged.

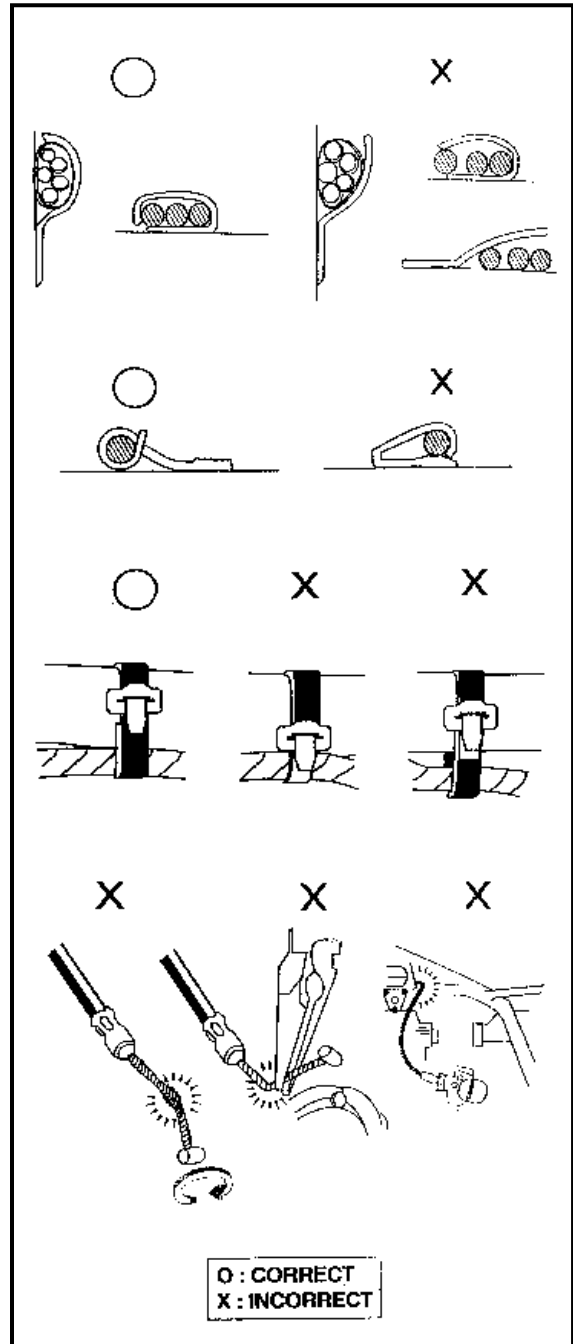

## Motorcycle Identification

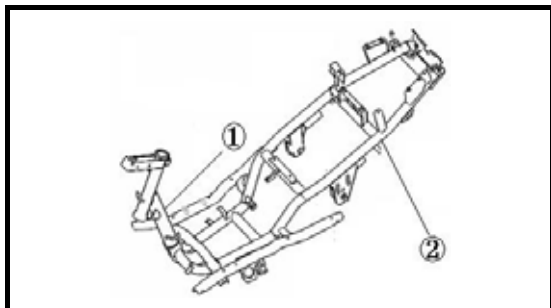

frame.

Figure 1-1

1. The vehicle identification number (VIN) is inscribed at ① on the frame. See Figure 1-1. Identification number: LBBB9212?????????. On the VIN, the 10<sup>th</sup> digit shows the year of manufacture and the 11<sup>th</sup> digit shows the code of the manufacture plant. The anti-refit name plate is stuck inside the helmet bucket; the frame name plate is riveted to ② on the

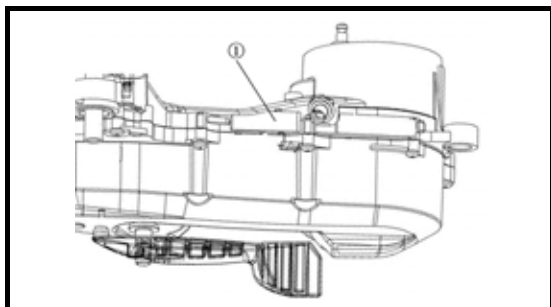

Figure 1-2

2. The engine series number ① is inscribed on the crankcase housing. See Figure 1-2.

## Important Notices

1. Please use genuine parts of Qianjiang Motorcycle. Use of the parts that fail the design specifications of Qianjiang Motorcycle may cause damage to engine.

2. During servicing, use metric tools only. Do not interchange a metric bolt, nut or screw and an English system fastener.
3. During reassembly, replace with new washers, O-rings, cotter pins and locking pieces.
4. When tightening bolts or nuts, tighten the ones with larger diameters or comparatively located at inside first, and then tighten all bolts or nuts diagonally to specified torques step by step unless described otherwise.
5. Clean the removed parts with washing fluid. Before assembly, lubricate all sliding planes.
6. After assembly, check all parts for proper installation and correct operation.
7. Before measurement, remove dirt and oil; during assembly, add recommended lubricants to oil sites.
8. When engine and driveline require a long-term storage after dismantled, please apply lubricant to surfaces of parts to prevent rust and dust accumulation.

## Specific tools

The so-called specific tools refer to those specifically designed for assemble or dismantle of certain components of the motorcycle. These tools are usually used in specific locations. Appropriate specific tools are indispensable in the complete and accurate adjustment as well as in the assembly operations. By taking advantage of specific tools, the components can be safely, reliably and quickly assemble or dismantle, thus enhancing the work efficiency and saving lots of efforts.

### 1 . tools used for the engine-overhaul

When assembling or dismantling the engine, specifically designed tools should be used for some certain components to guarantee a smooth dismantling.

The list of specific tools for the assembly and dismantling of engine components and the figure of real objects can be seen in table 1-1 and table 1-2.

**Table 1-1**

Name	Remarks
Specialized circular wrench	Used for the assembly and dismantle of flywheel bolt ,figure 1-3 Figure 1-4 Figure 1-5 Figure 1-6 Figure 1-7 Figure 1-8 Figure 1-9 Figure 1-10 Figure 1-11 Figure 1-12 Figure 1-13 Figure 1-14 Figure 1-15 Measure the inner canon of piston pin,Figure 1-16
Clutch holder	
Flywheel extractor	
Spacer gauge	
Dismounting tools for bearing	
Assembling tools for bearing	
Oil-seal dismounting tool	
Handle of dismounting tools	
Piston pin exhaustion apparatus	
Piston ring opening pincer	
Heating plug circular wrench	
Measure the thickness of clutch	
Cylinder diameter tester	
Dial dictator	

**Successive table 1-2**

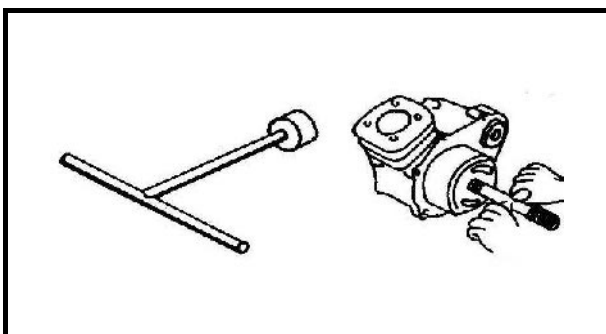

Figure 1-3

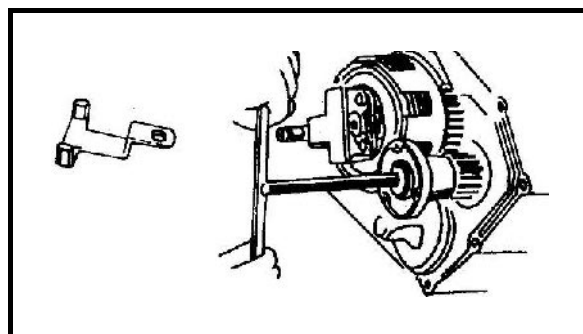

Figure 1-4

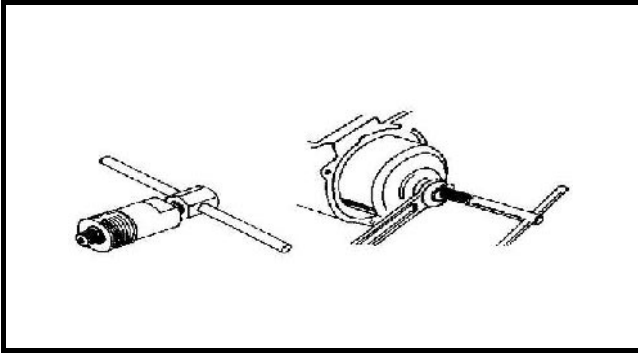
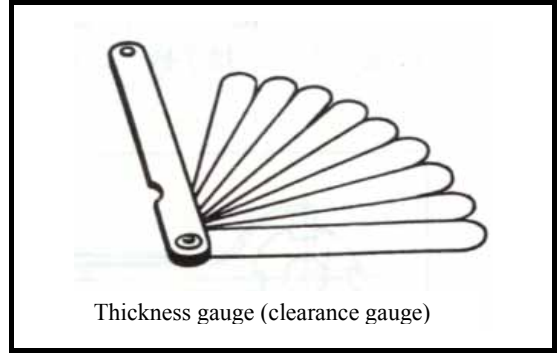

Figure 1-5



Thickness gauge (clearance gauge)

Figure 1-6

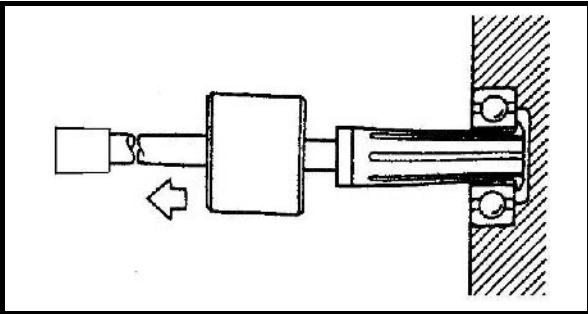

Figure 1-7

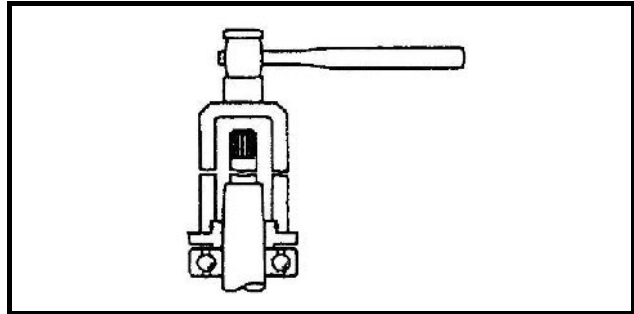

Figure 1-8

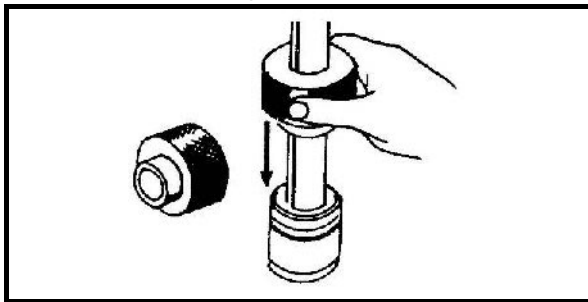

Figure 1-9

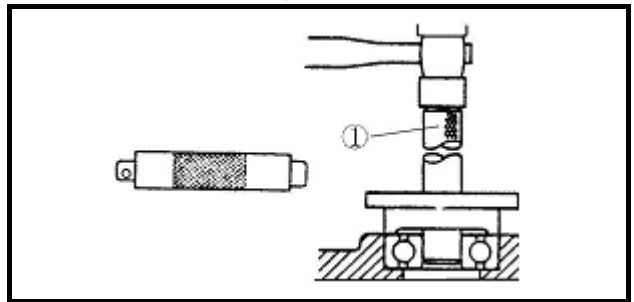

Figure 1-10  
①Handle

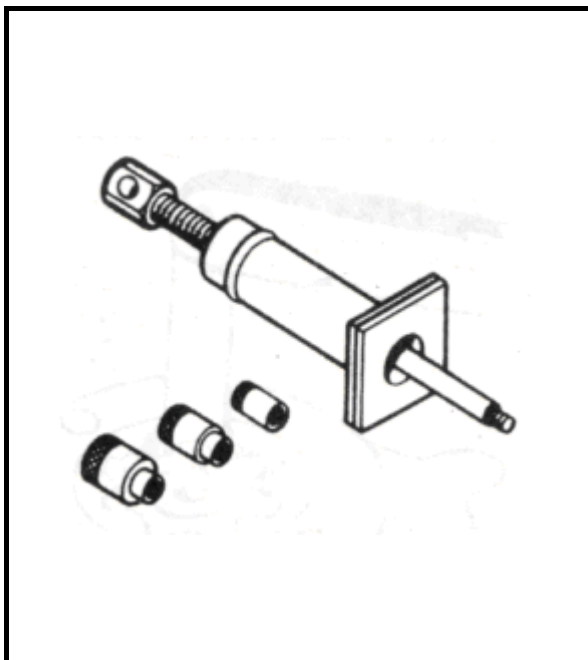

Figure 1-11

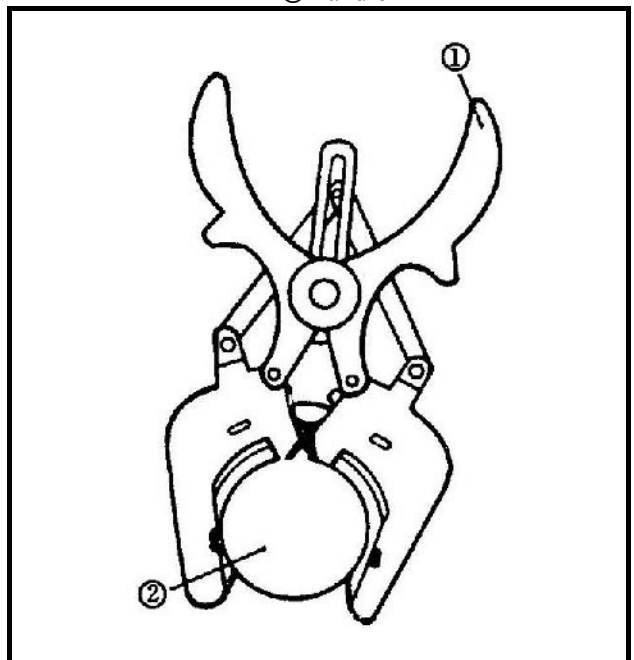

Figure 1-12



① opening pincer ② piston

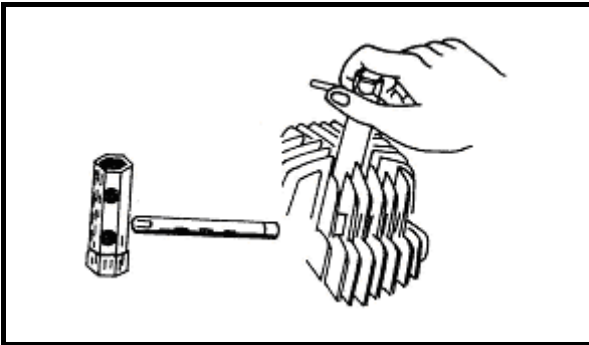

Figure 1-13

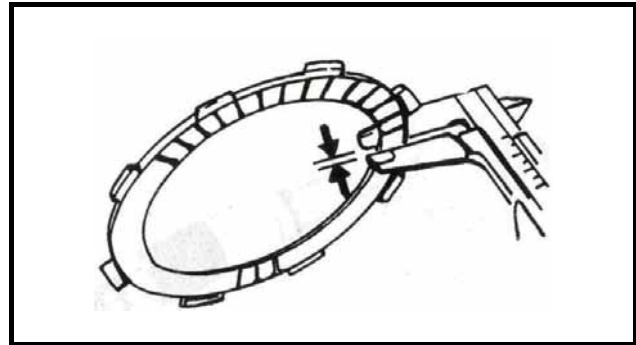

Figure 1-14

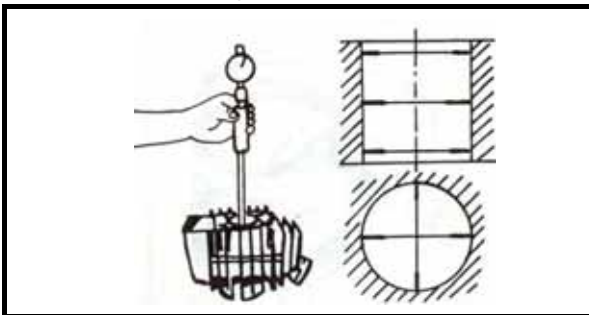

Figure 1-15

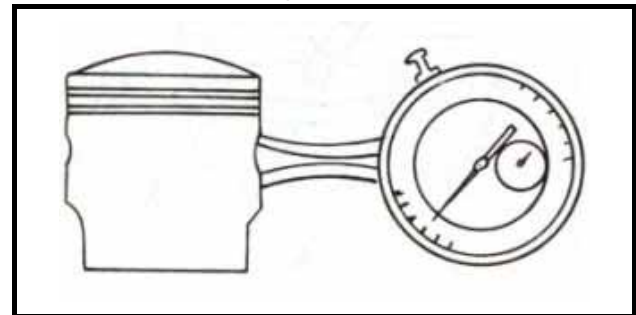

Figure 1-16

## 2 . Tools used for the underpan-overhaul

The list of general tools and specific tools for the dismantling of underpan components as well as the figure of real objects can be seen in table 1-17 and table 1-18.

**Figure 1-17**

Name	Remarks
rest wrench	Figure 1-19
inner hexagon wrench	Figure 1-20
circular wrench	Figure 1-21
micrometer	Figure 1-22
magnetic stand, V-shape block	Figure 1-23
dial indicator	Figure 1-24
square caliper	Figure 1-25
spring clip-ring clipper	Figure 1-26
whack-type screw drive	Figure 1-27
front fork oil seal dismantling tools	Figure 1-28
front part seal element driving-in tools	Figure 1-29
steering nut wrench	Figure 1-30

( 1 ) General tools for the underpan-overhaul

**Successive table 1-18**

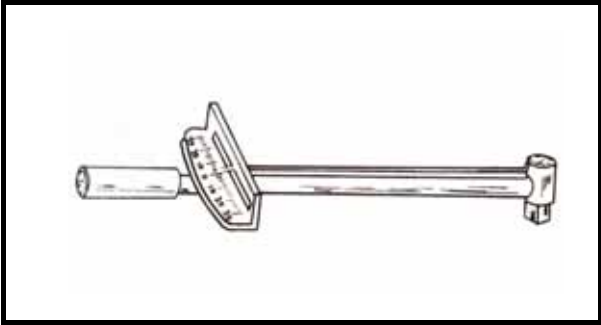

Figure 1-19

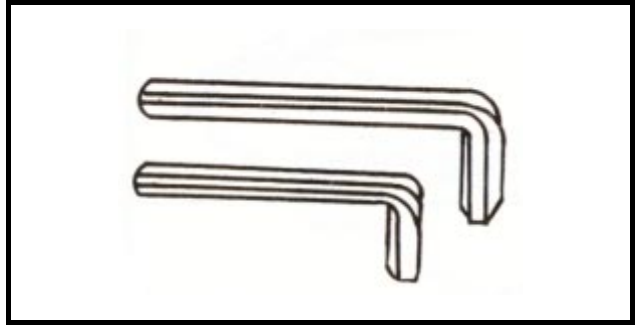
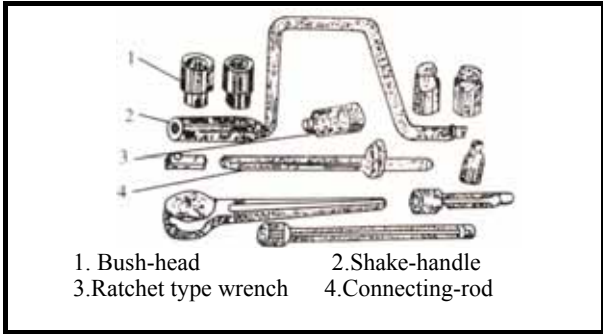

Figure 1-20



- 1. Bush-head
- 2. Shake-handle
- 3. Ratchet type wrench
- 4. Connecting-rod

Figure 1-21

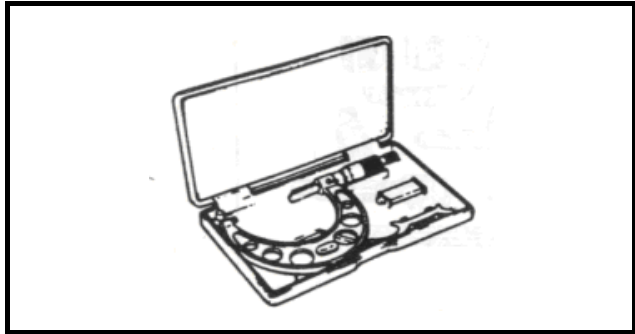

Figure 1-22

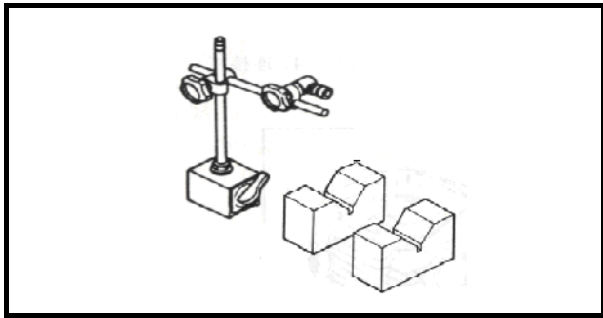

Figure 1-23



Figure 1-24

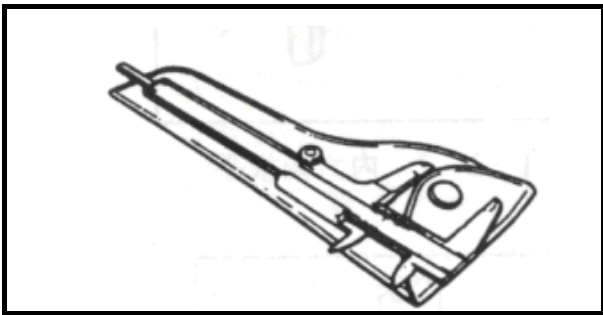

Figure 1-25

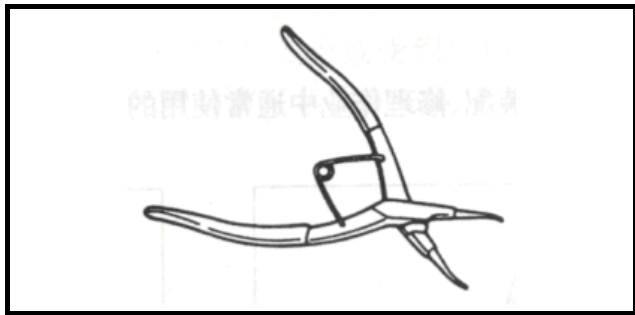

Figure 1-26

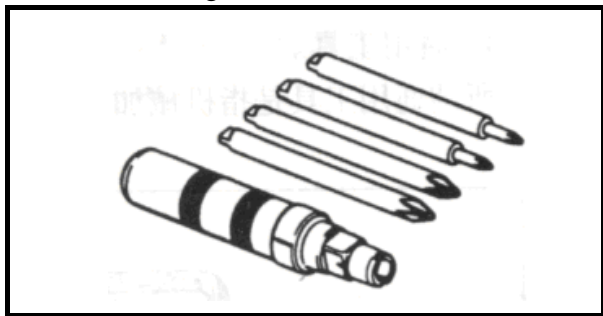

Figure 1-27

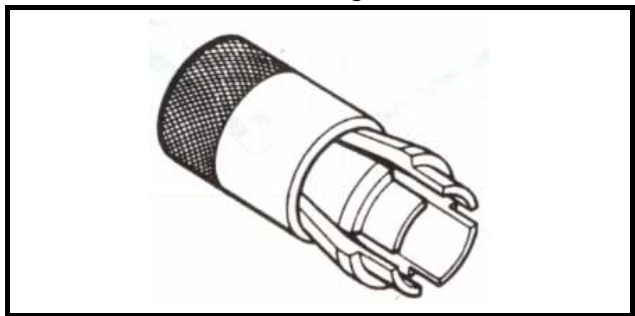

Figure 1-28

( 2 ) Specific tools for underpan-overhaul: front fork seal element driving-in tools

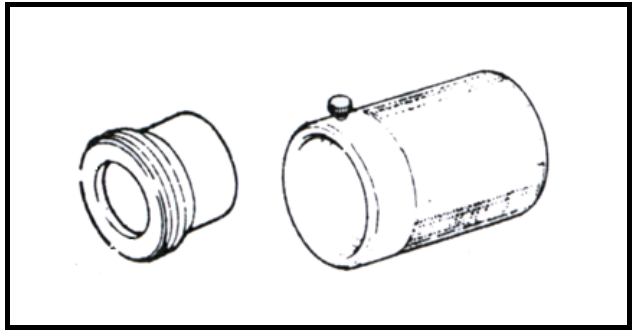
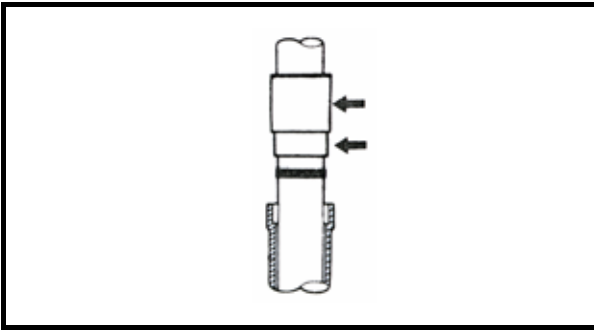

Figure 1-29

( 3 ) Steering nut wrench

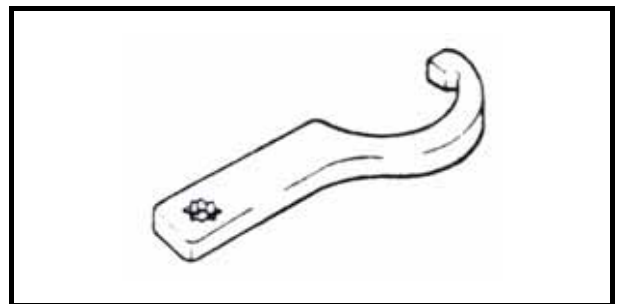
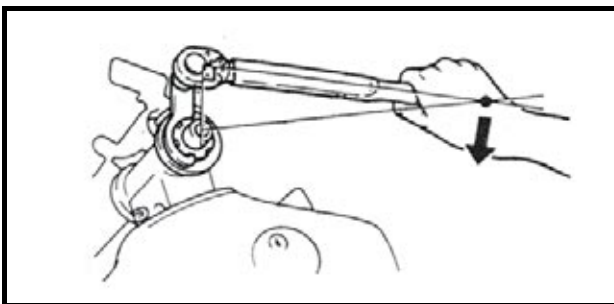

Figure 1-30

3 . Tools used for electric apparatus components

The list of specific tools for the testing of electric apparatus components, as well as the figure of real objects can be seen in table 1-31 and table 1-32.

**Table 1-31**

Name	Remarks
universal meter	Figure 1-33
ignition tester	Figure 1-34

**Successive table 1-32**

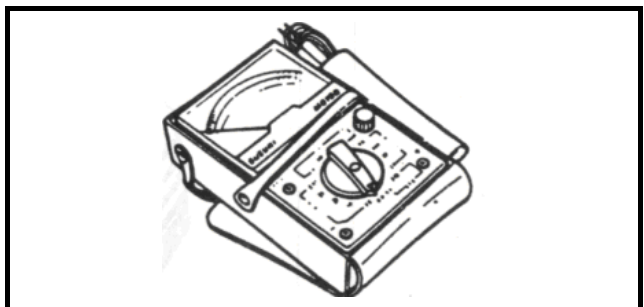
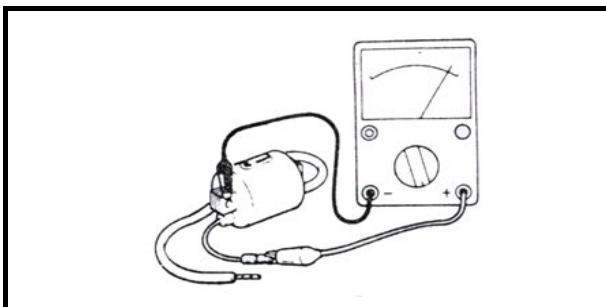

Figure 1-33

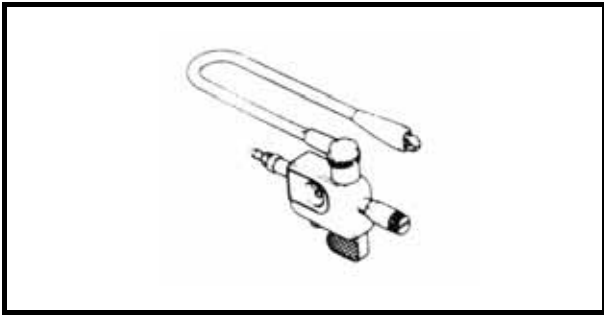
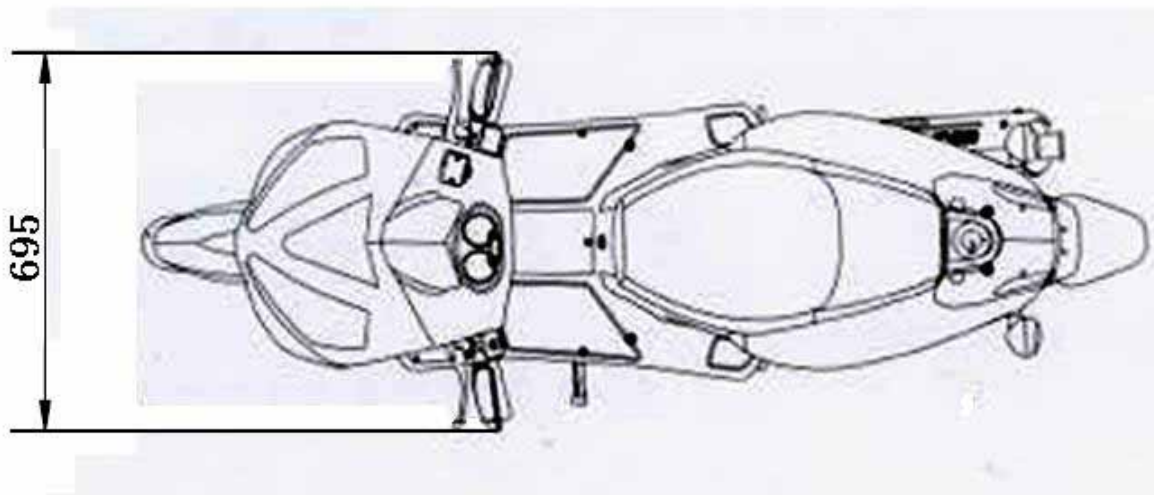
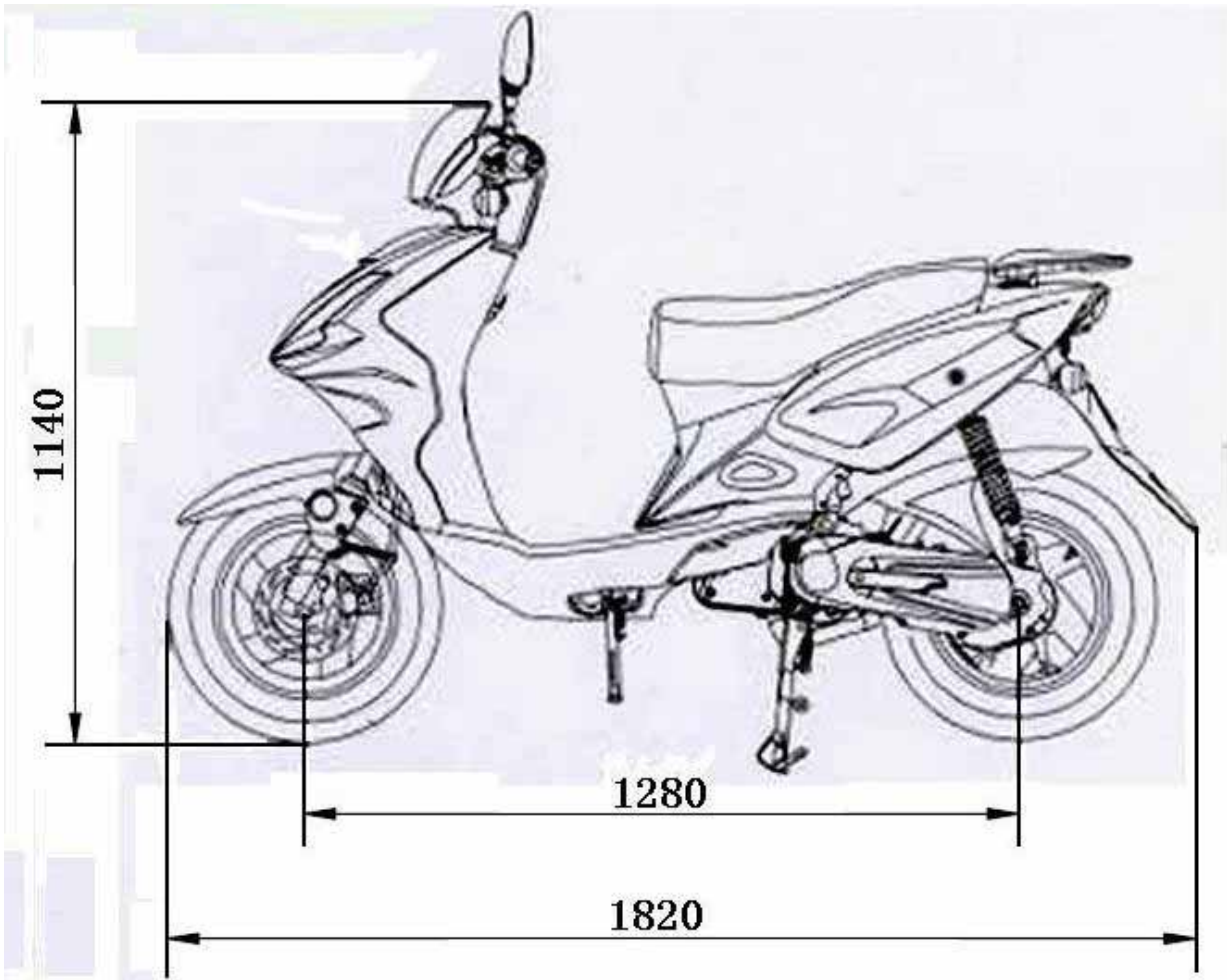

Figure 1-34

## Specification Sheet (RACE 50)

<b>Model</b>		<b>RACE 50</b>		<b>Engine</b>	<b>Engine Type</b>	QJ1E40QMB-4
<b>Full length mm</b>		1820			Fuel type	Unleaded gasoline ( 92/95 )
<b>Full width mm</b>		695			Number of cylinders	1
<b>Full height mm</b>		1140			Inside measure * stroke	40×39.2
<b>Wheelbase mm</b>		1280			Total flow rate	49.2
<b>Vehicle weight kg (serving quality)</b>		<b>Front axle</b>	37		Start mode	Start by electricity Foot start mechanism
		<b>Rear axle</b>	55		Cooling mode	Wind-cooling
		<b>Total</b>	92		Lubrication	Lubricate separately
<b>Tyre specification</b>		Outer cover of front wheel	120/70-12		Air cleaner	3XG
		Front rim	3.50×12		Petrol capacity	5±0.2L
		Outer cover of rear wheel	130/70-12	Carburetor type	IIF-45	
		Rear rim	3.50×12	Idling speed - rpm	1750±100rpm/min	
<b>Gearing</b>	Clutch type	Dry-centrifugal type		<b>Perform ance</b>	Maximum torque	4.3 N.m/5500rpm
	Transmission	Stepless shift			Maximum torque	2.50kW/6000 rpm
	Driving mode	Belt drive			Compression ratio	6.9 : 1
<b>Electrical installation</b>	Battery capacity/type	12V-4AH/ dry-charged type			Maximum speed	45km/h
	Capacity of alternator	90W/8000rpm			<b>Brake</b>	Diameter of front brake disk ( mm )
	Spark plug	NGK/TORCH , BR7ES		Inner diameter of rear brake drum ( mm )		φ110mm
	Spark plug	0.6-0.7mm				
	Ignition mode	CDI				

# RACE 50





# Troubleshooting

## Trouble diagnosis program for engine start failure or difficulty

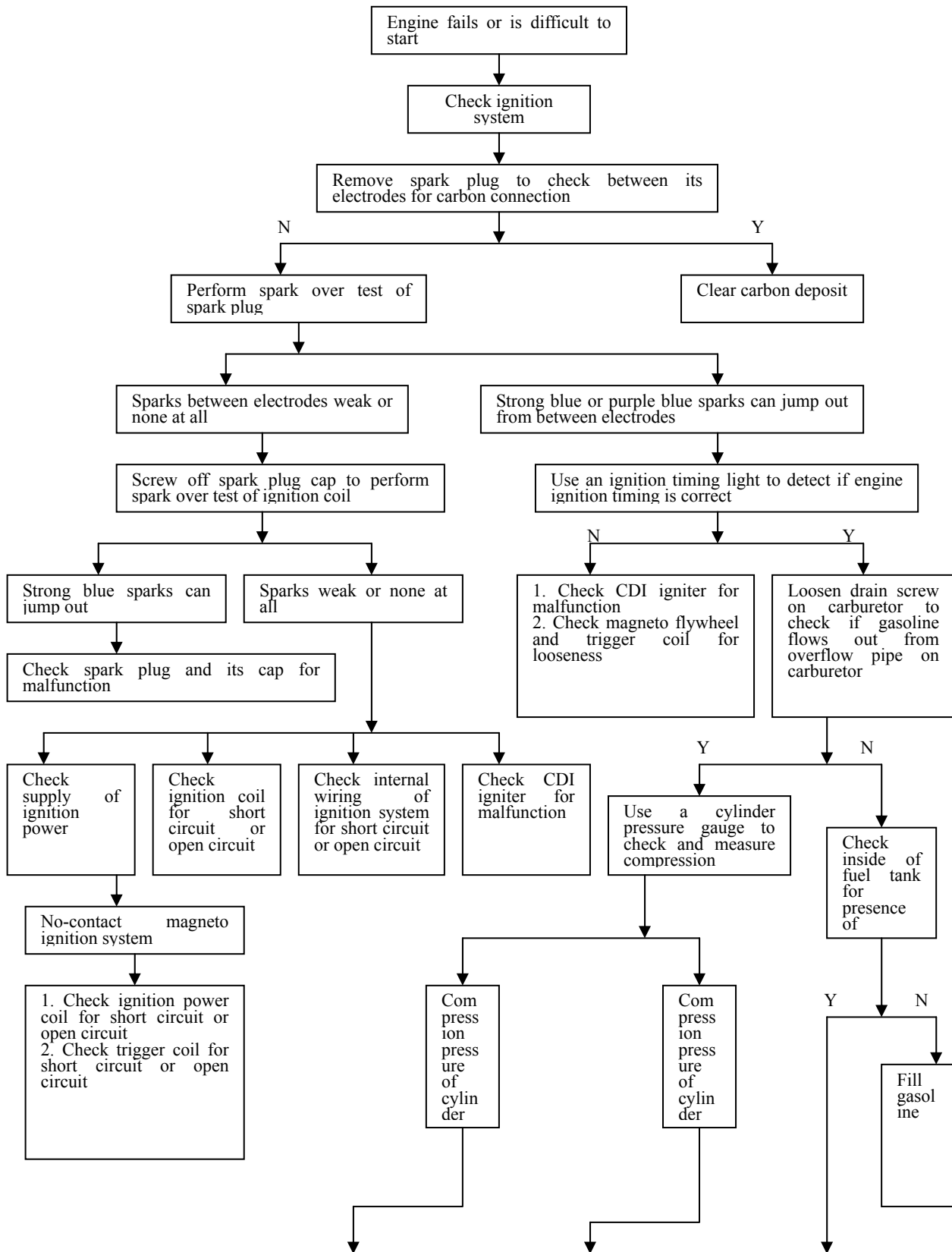



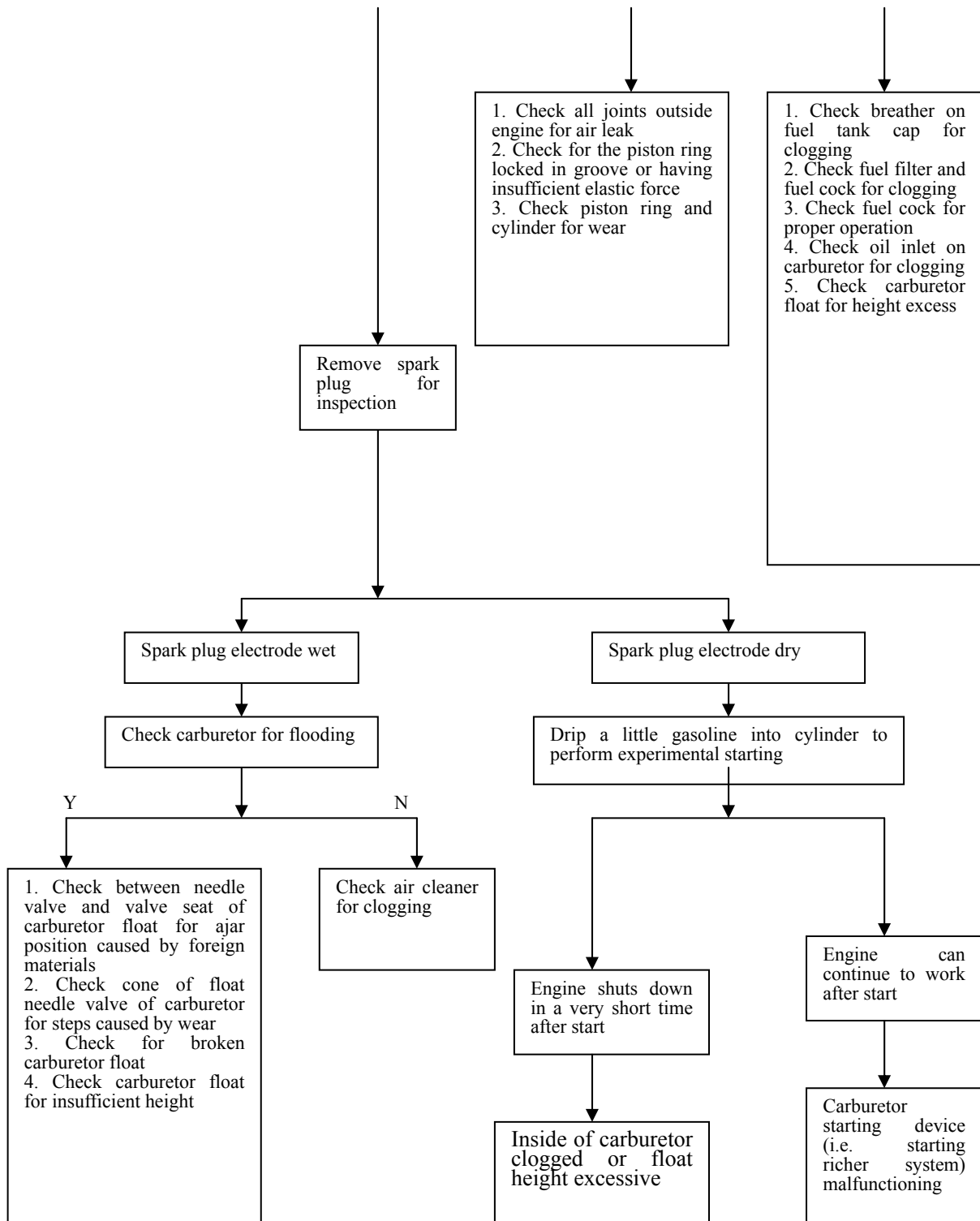

### Trouble diagnosis program for engine overheat

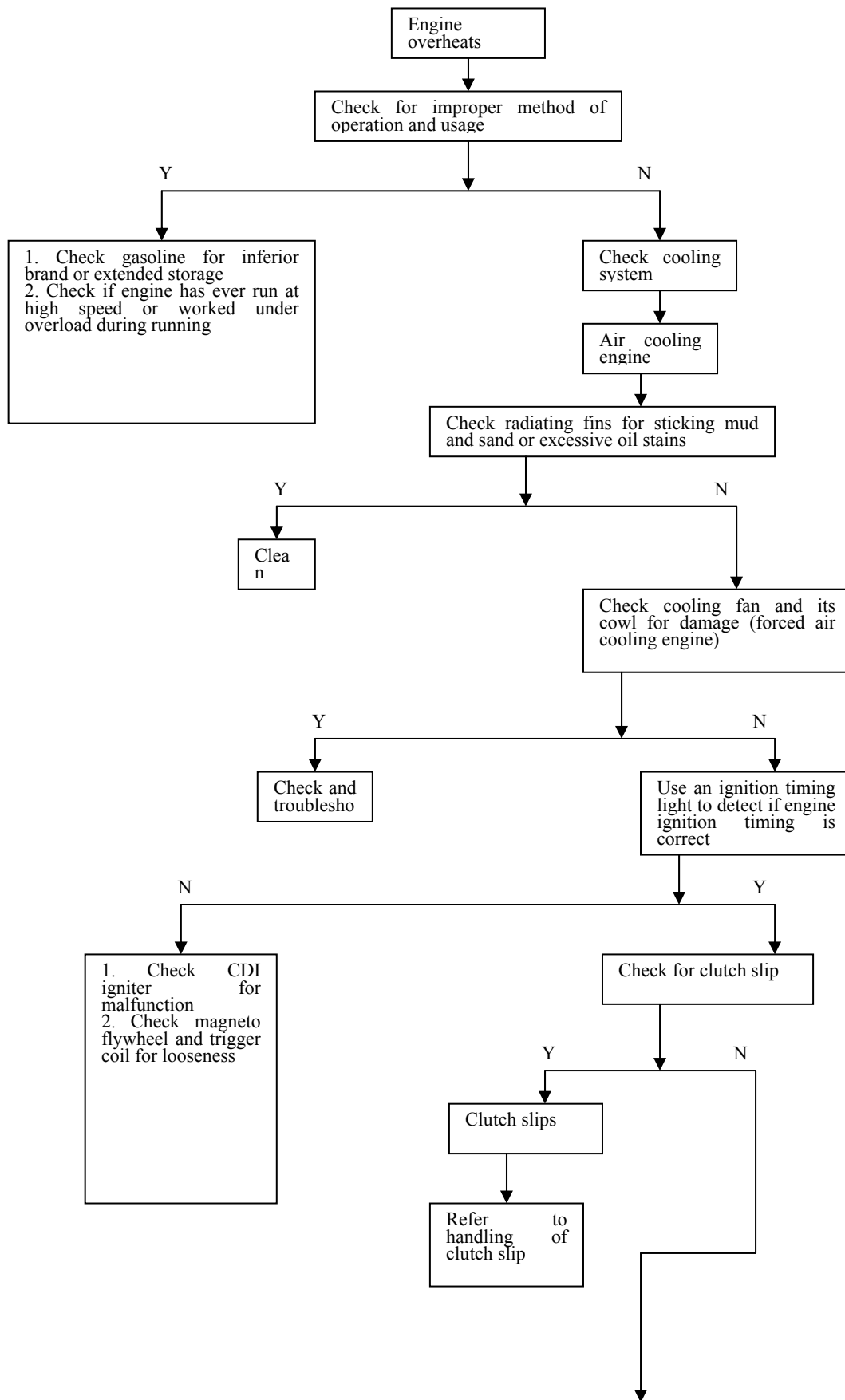

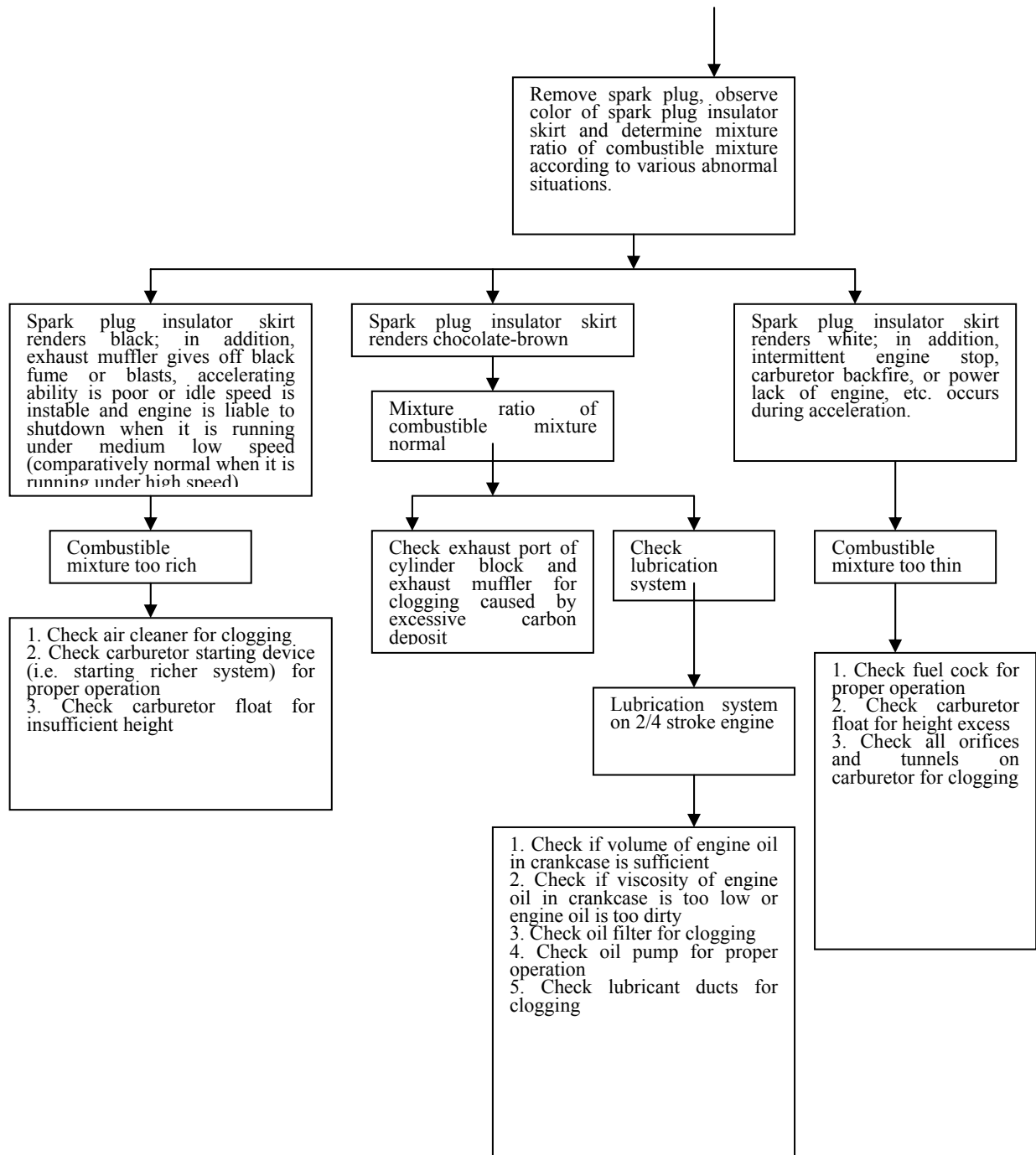



## Trouble diagnosis program for poor engine idle speed

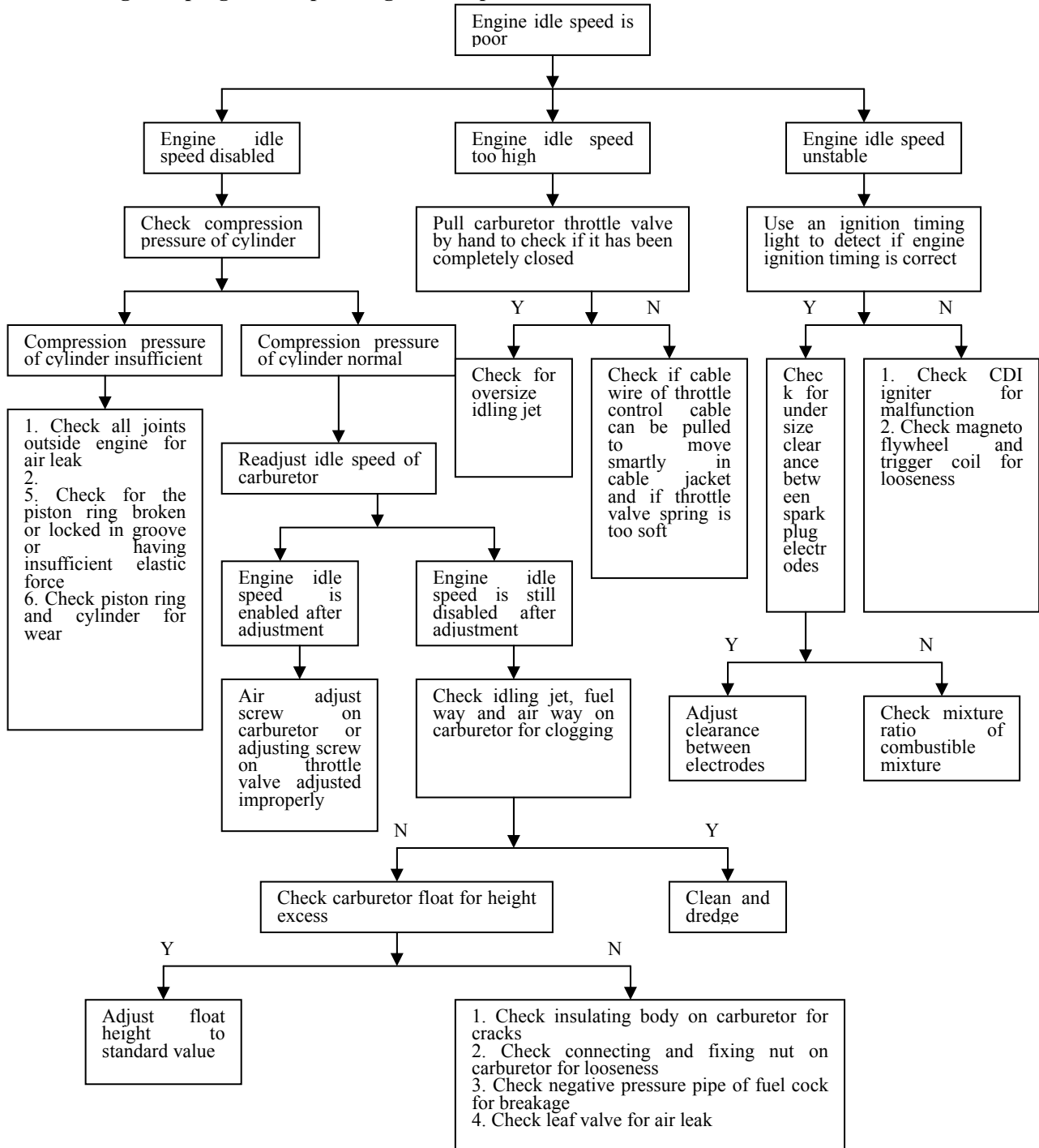

## Trouble diagnosis program for excessive fuel consumption

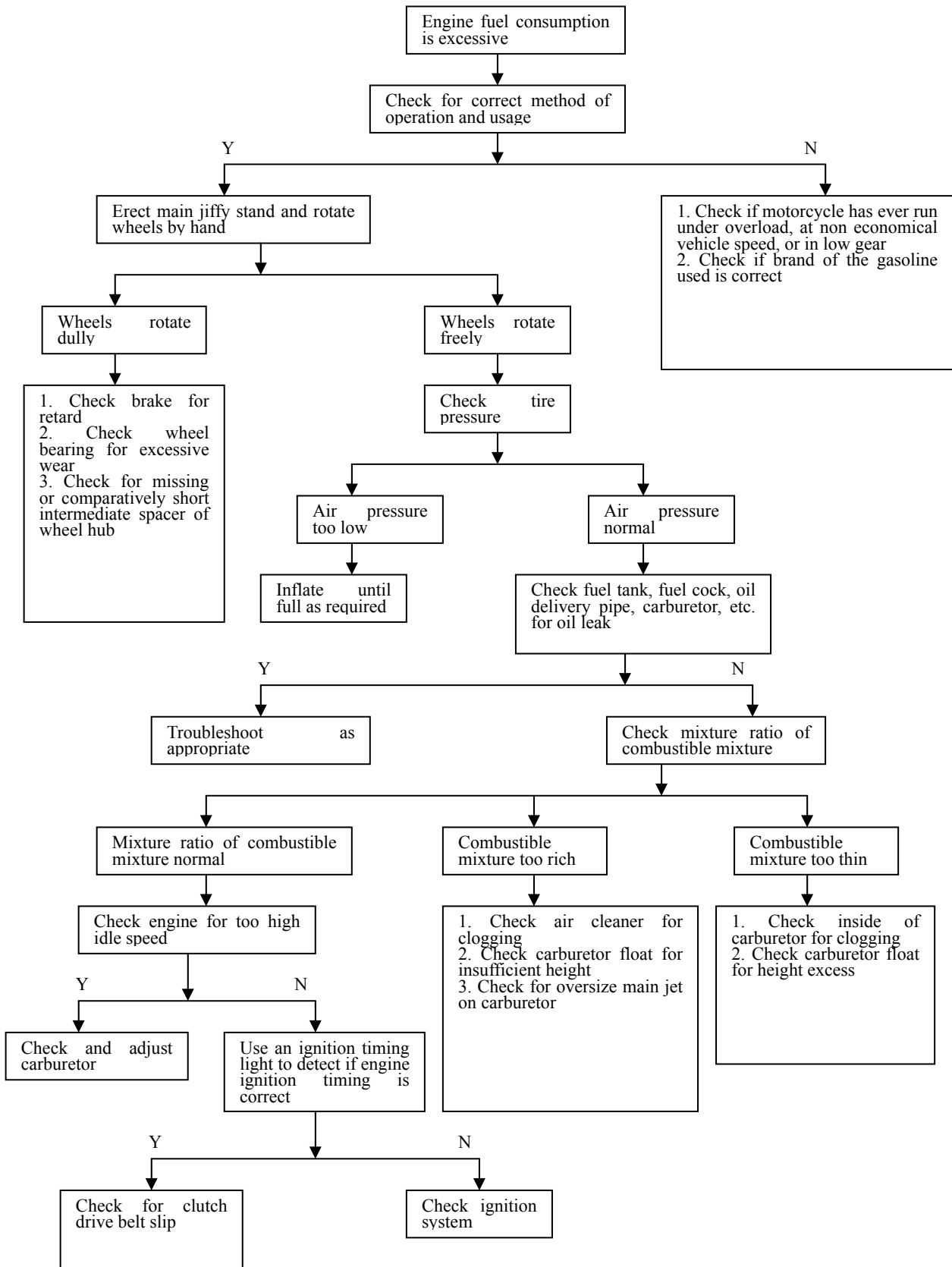

**Trouble diagnosis program for the malfunction that exhaust muffler on a 2 stroke engine gives off strong blue-white smoke**

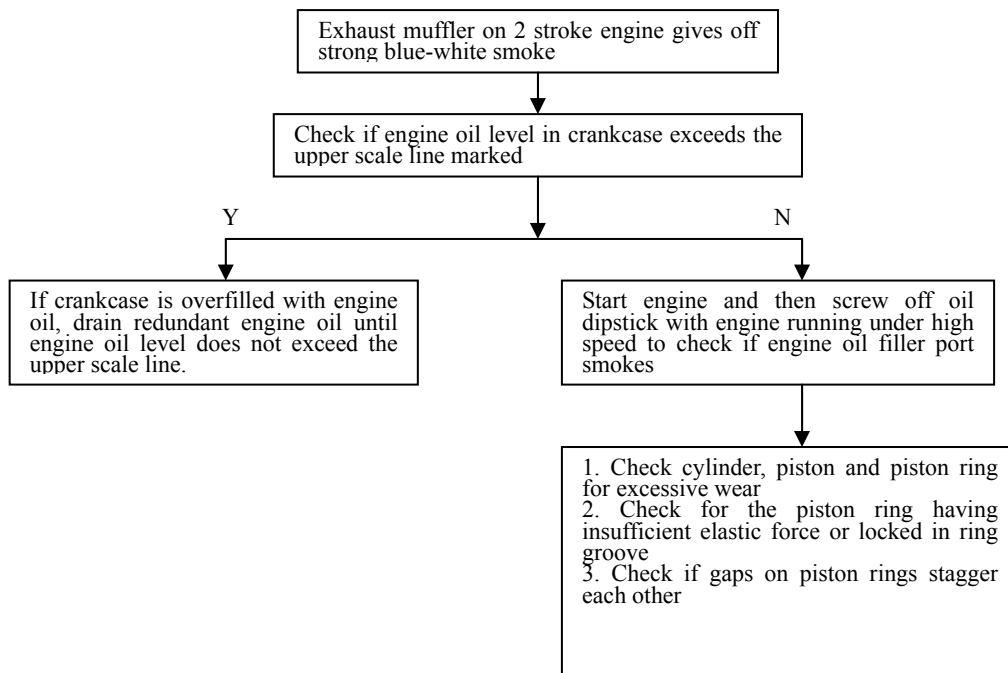

**Trouble diagnosis program for shift difficulty of transmission**

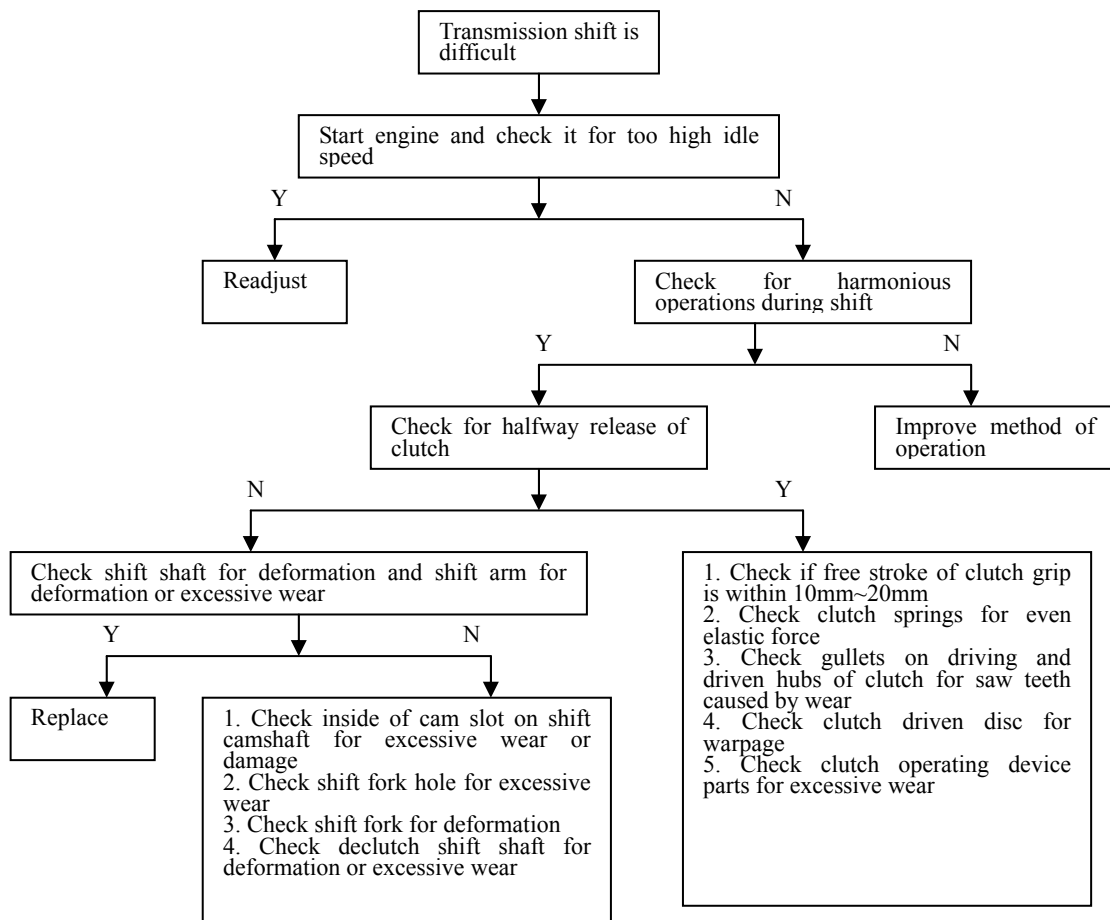

### Trouble diagnosis for trip stop of transmission

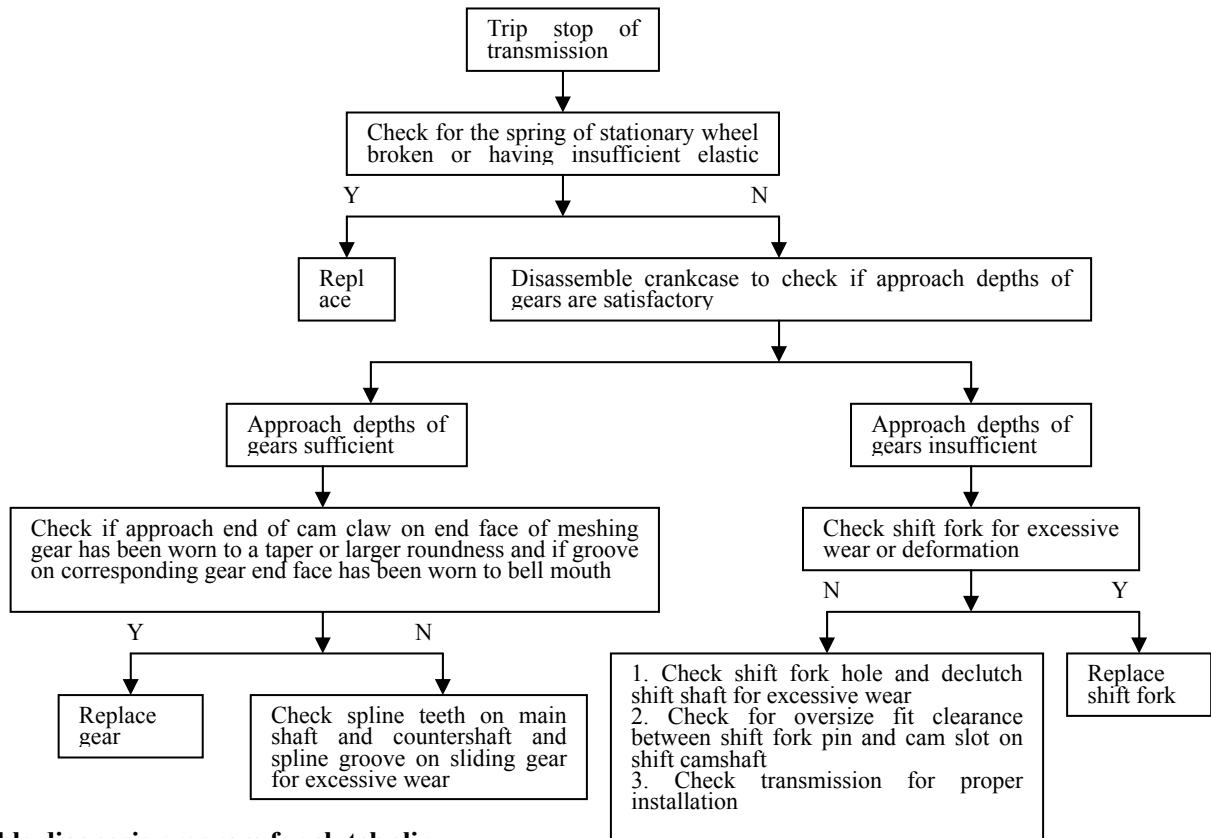

### Trouble diagnosis program for clutch slip

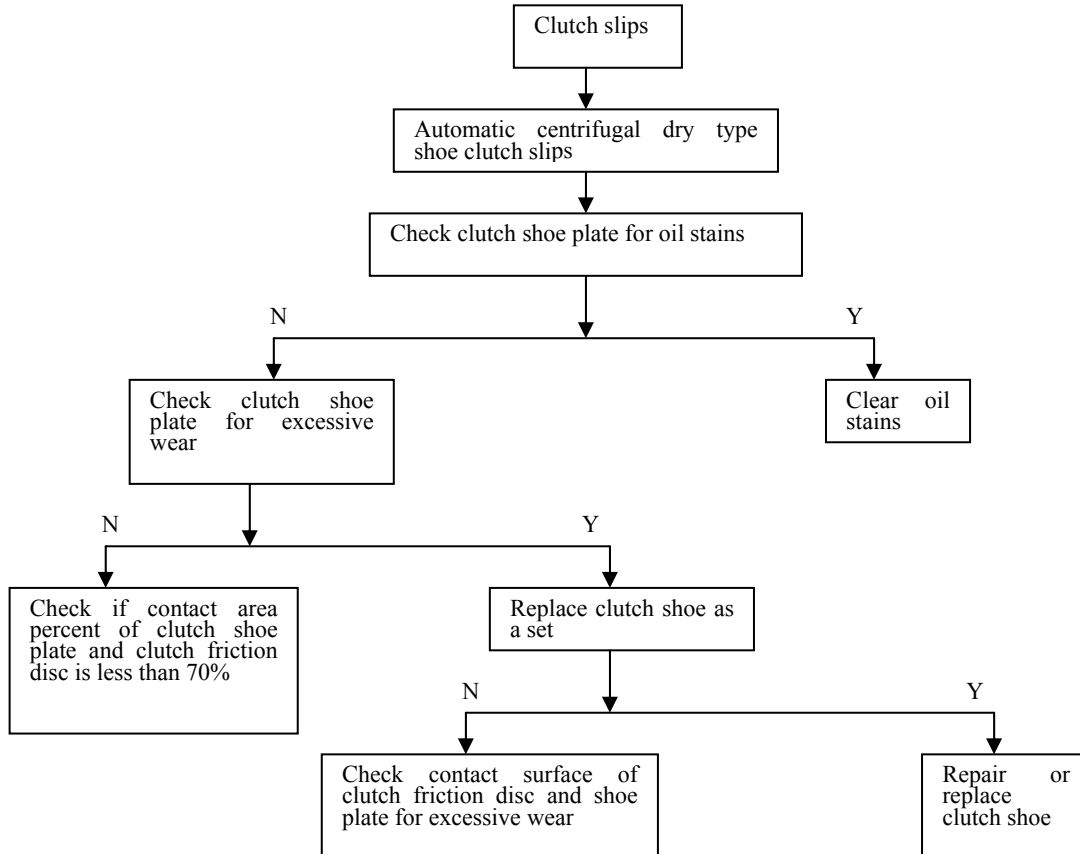



### Trouble diagnosis program for hydraulic disc brake failure

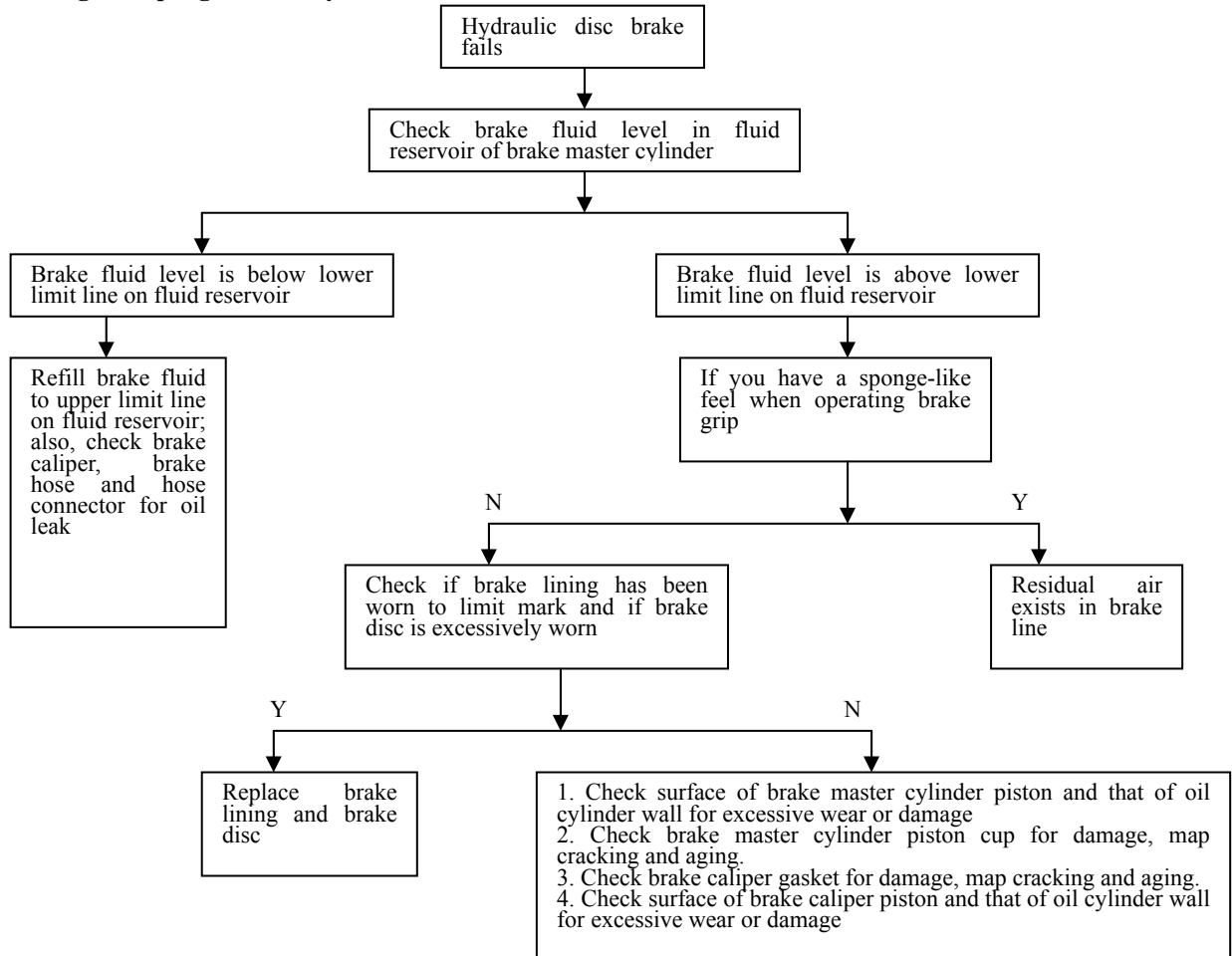

### Trouble diagnosis program for drum brake failure

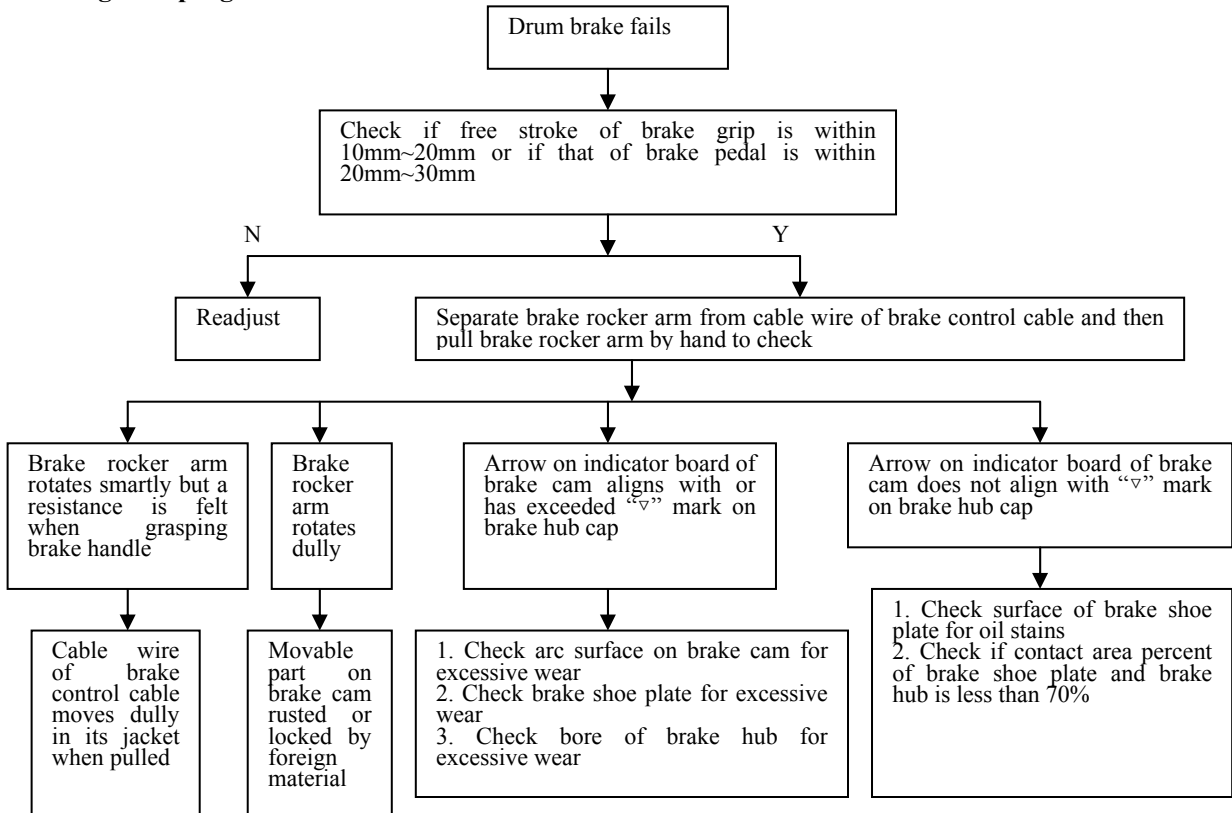

### Trouble diagnosis program for charge failure of battery

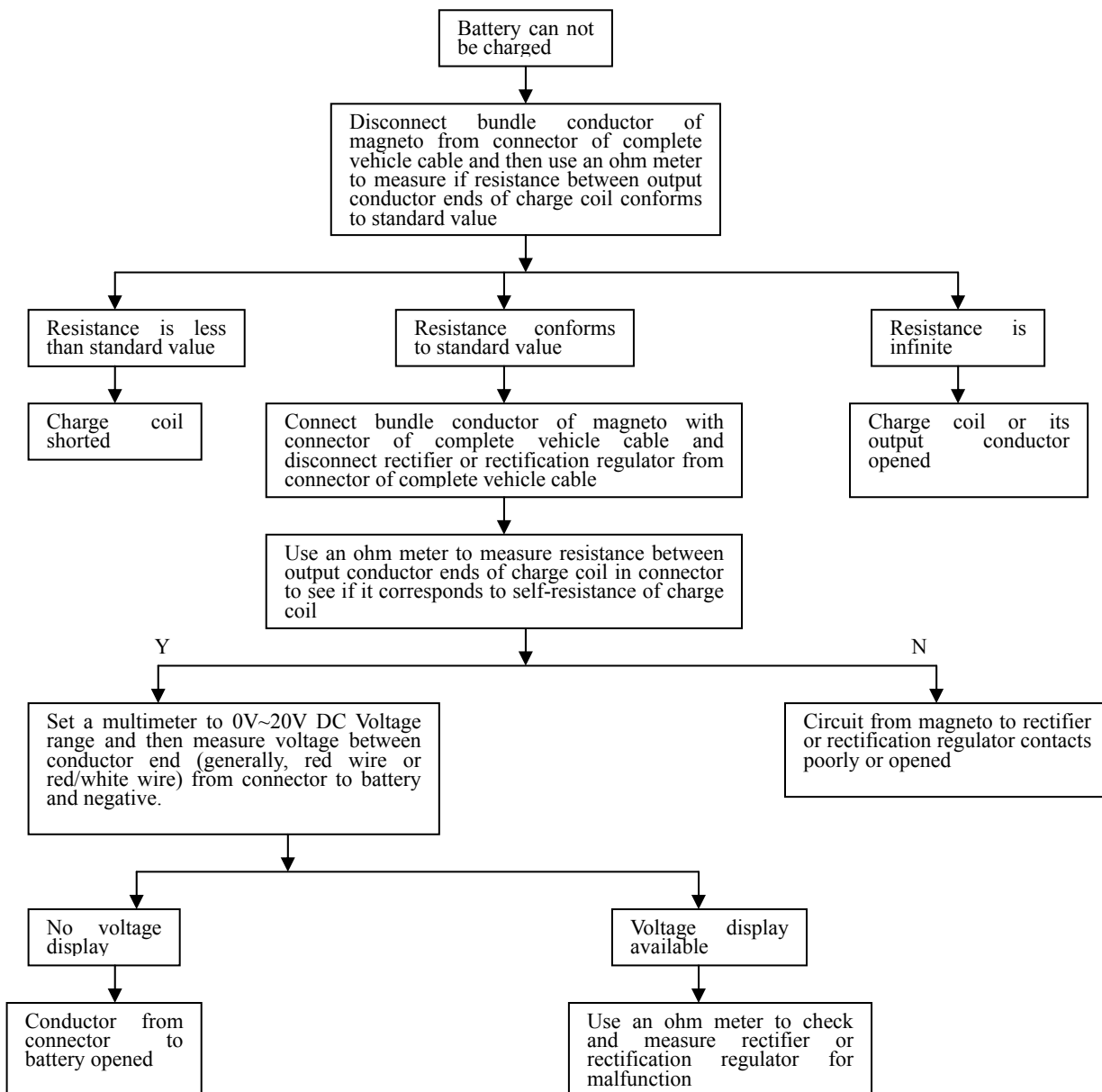

### Trouble diagnosis program for undercharge of battery

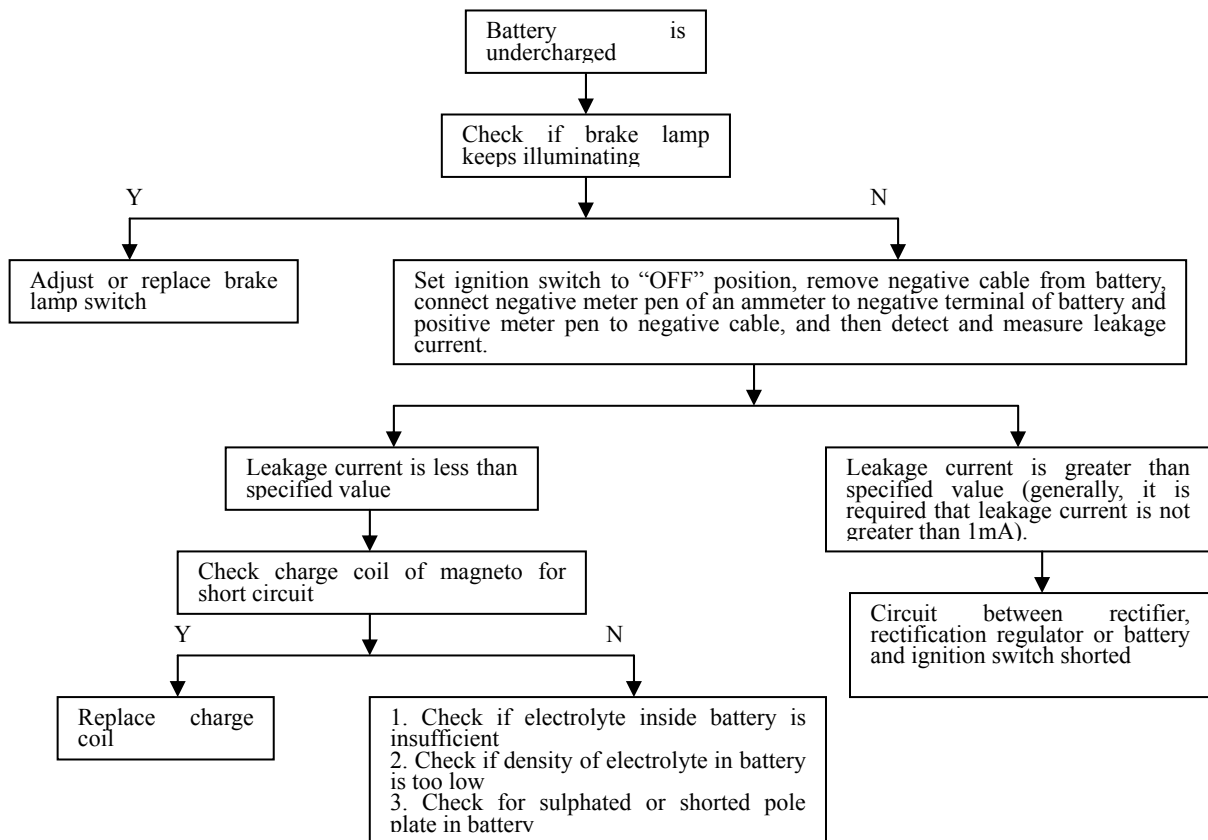

**Trouble diagnosis program for rotation failure of starting motor**

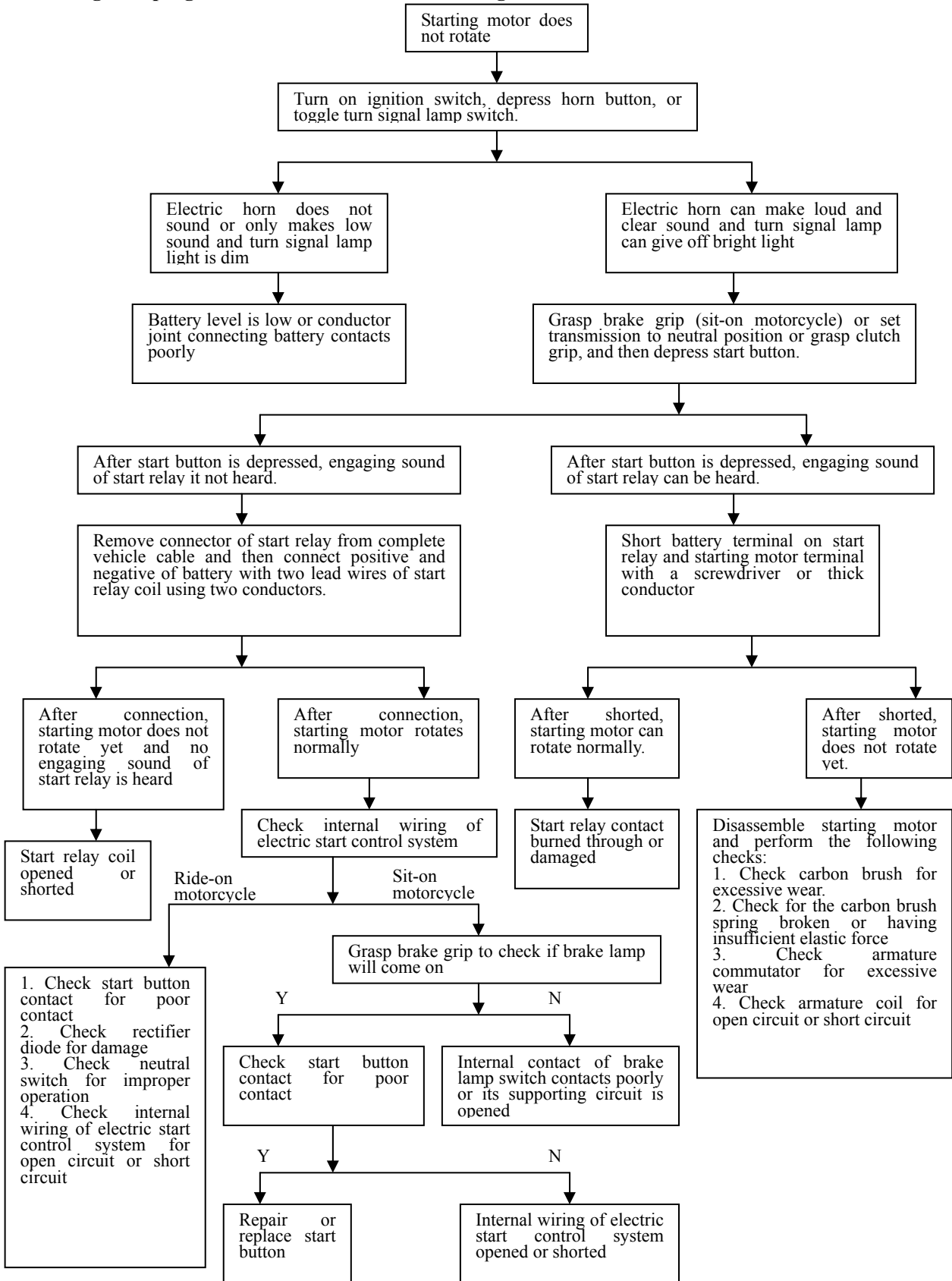

### Trouble diagnosis program for weak rotation of starting motor

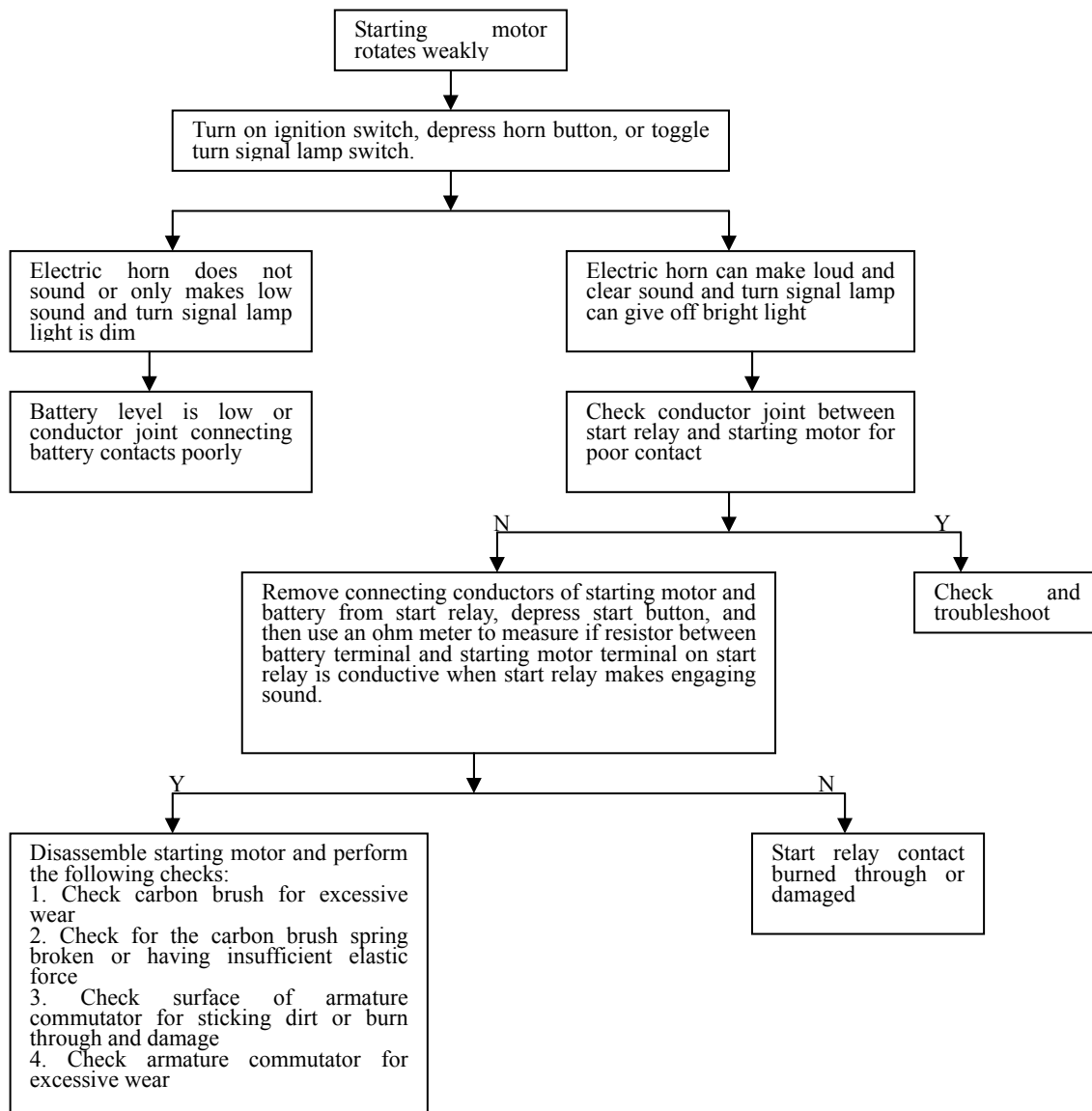

**Trouble diagnosis program for the malfunction that none of illuminating lamps comes on**

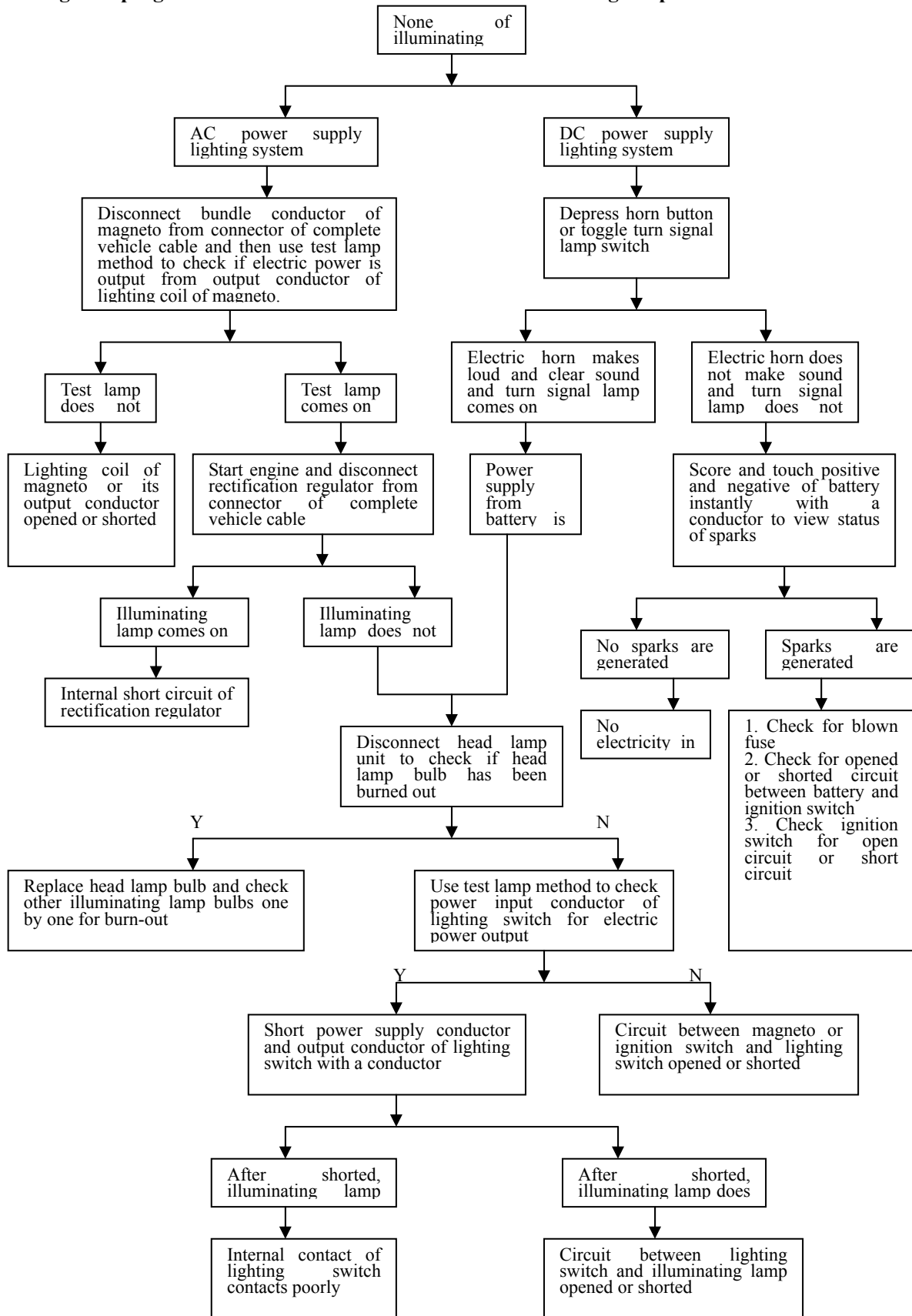

**Trouble diagnosis program for the malfunction that illuminating lamp bulb is liable to burn-out**

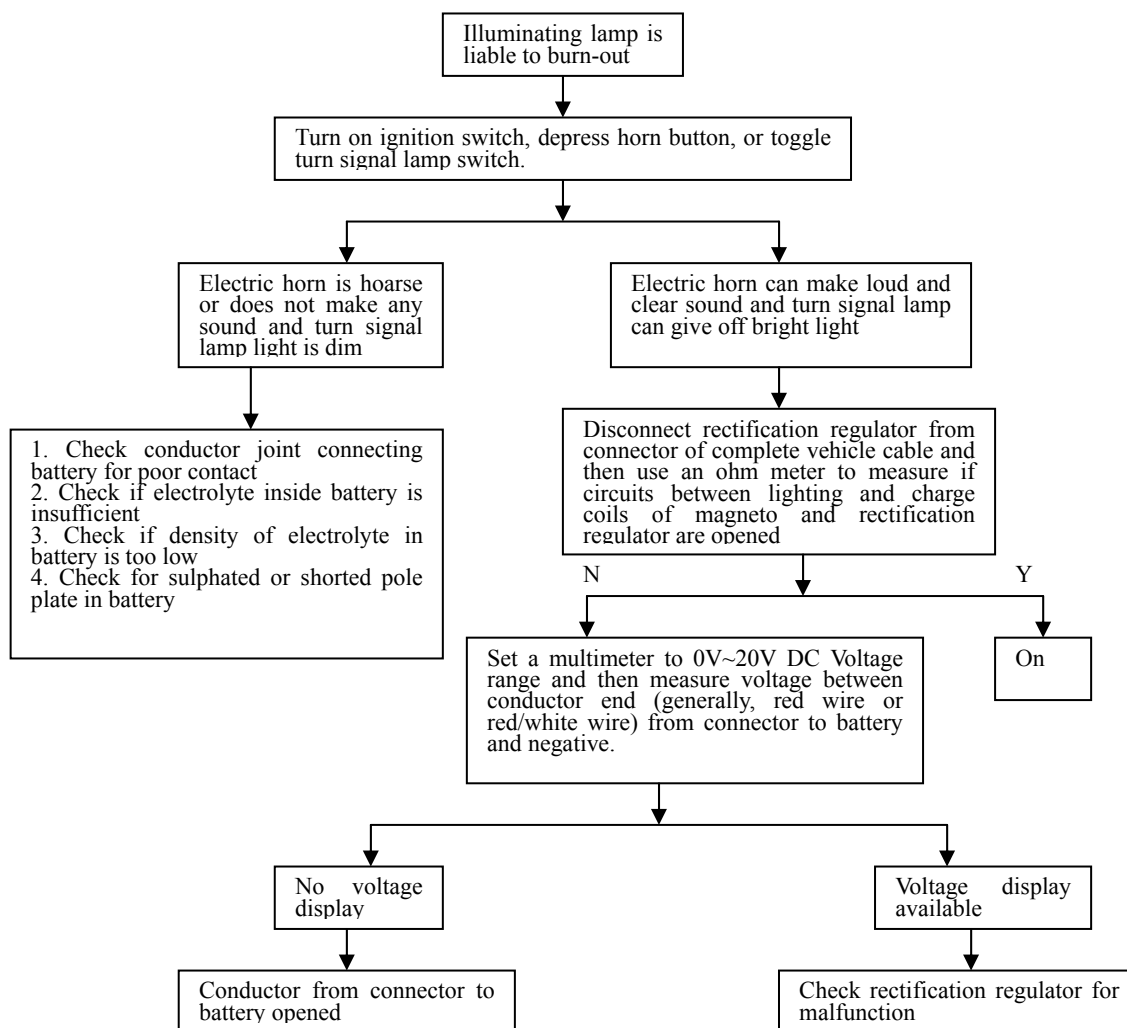

## Trouble diagnosis program for weak illuminating lamp light

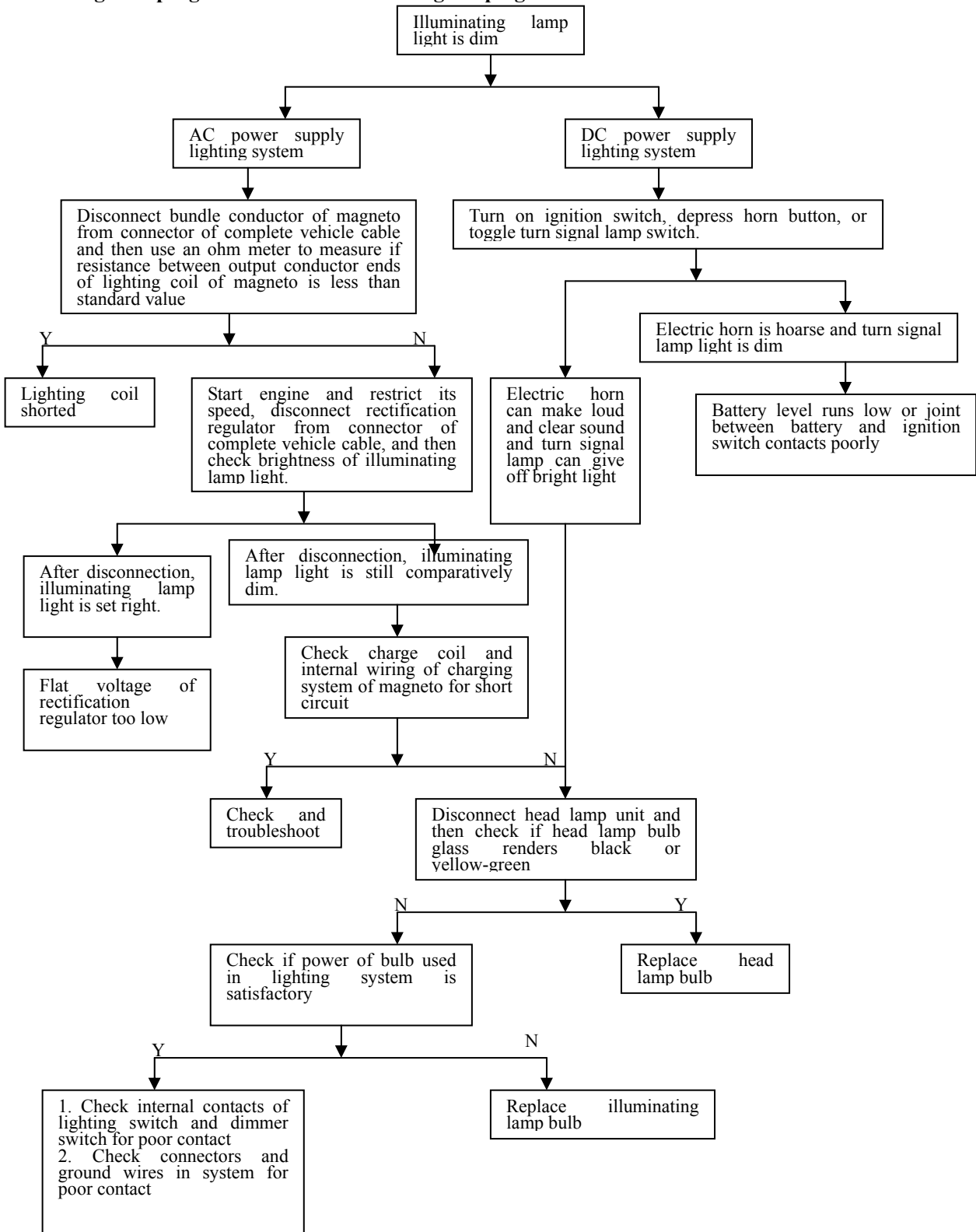



**Trouble diagnosis program for the malfunction that turn signal lamp does not come on**

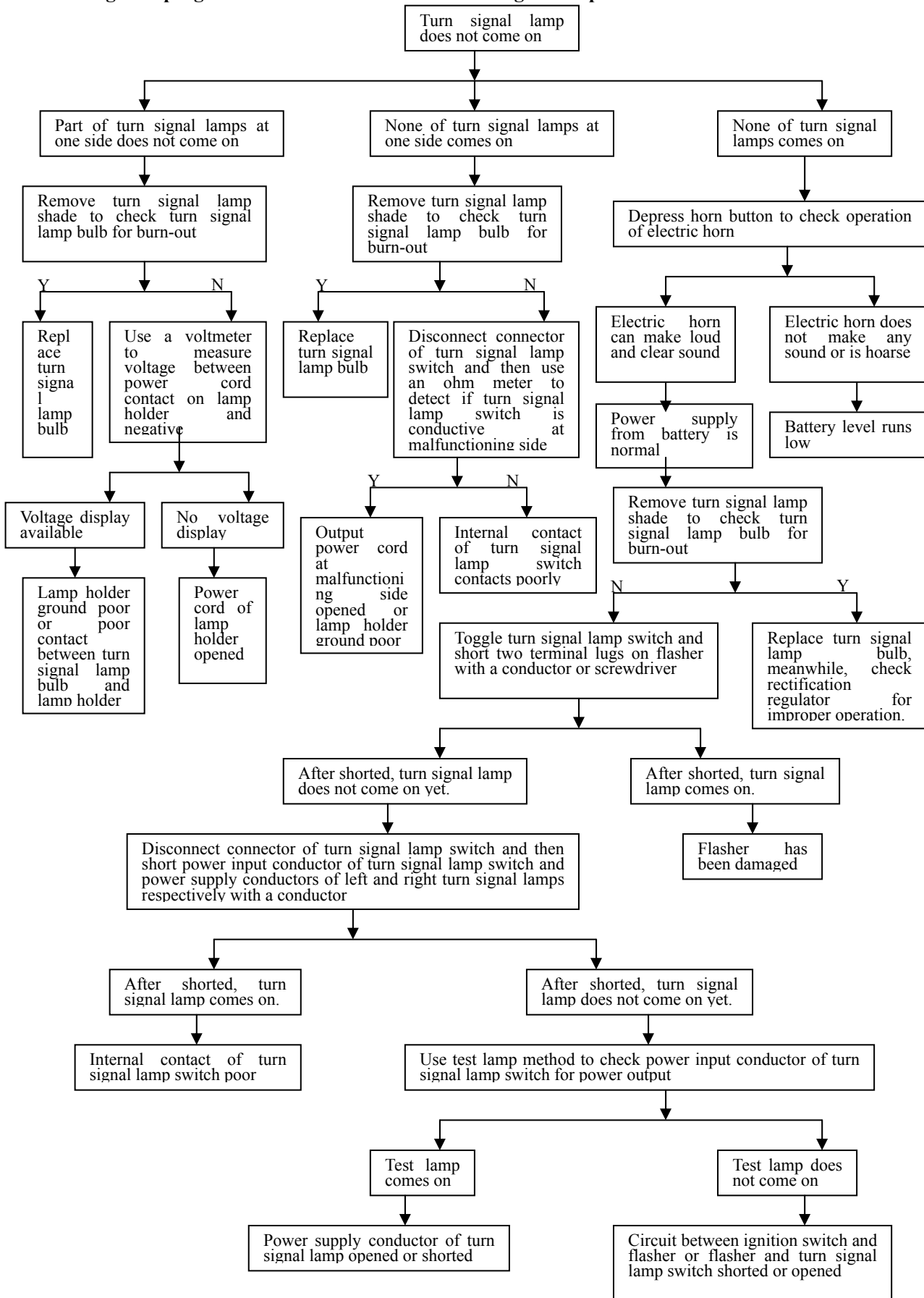

**Trouble diagnosis program for the malfunction that electric horn does not sound**

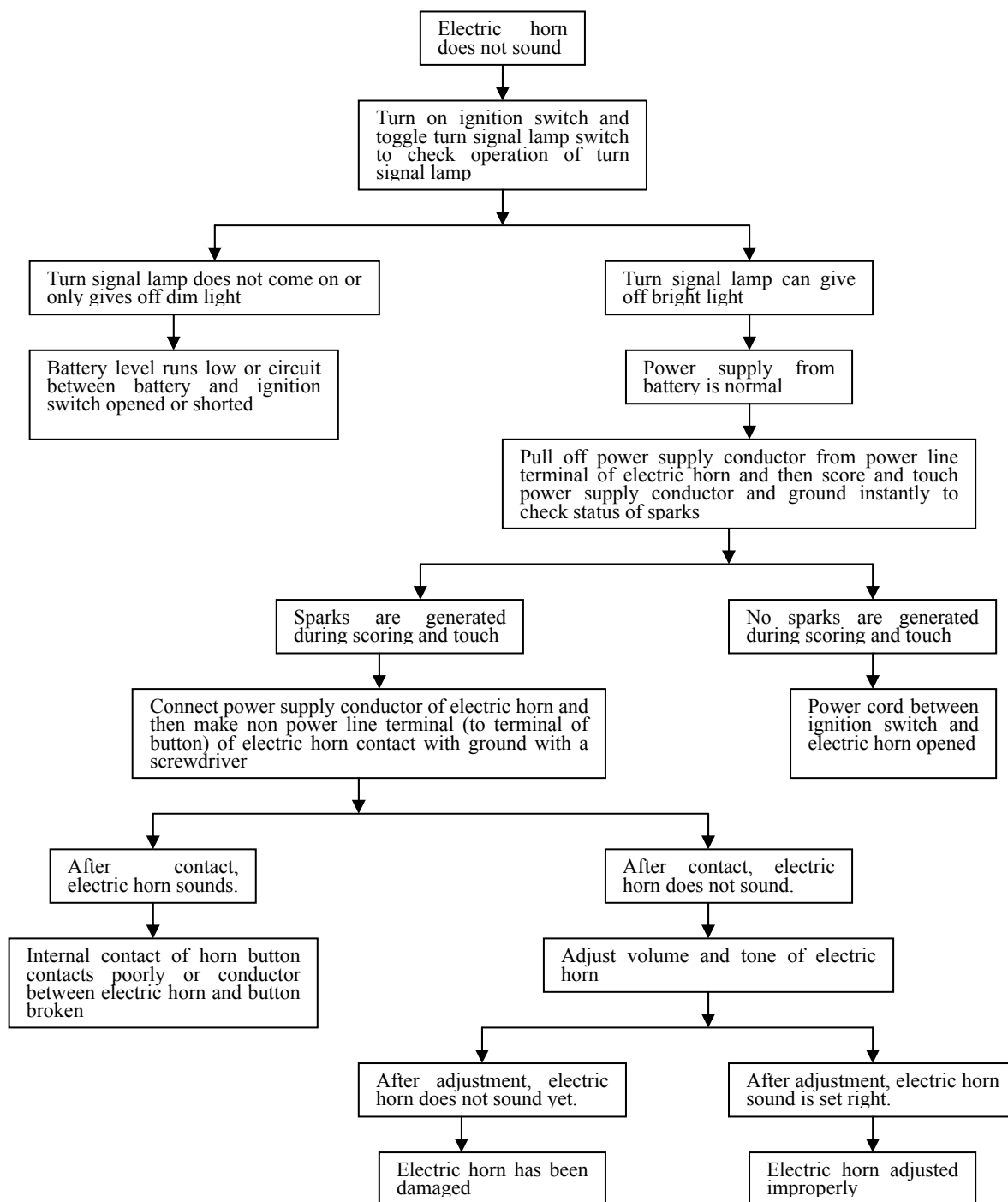

**Trouble diagnosis program for the malfunction that brake lamp does not come on**

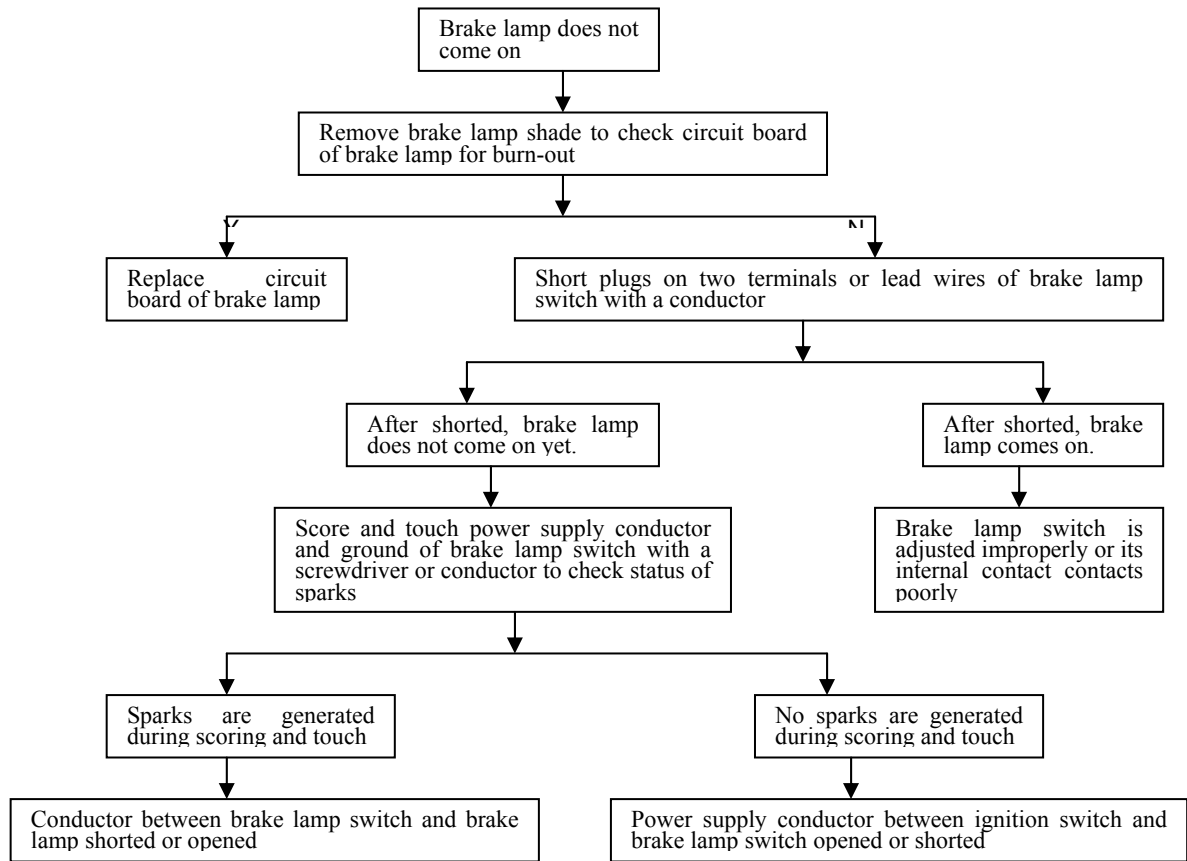

**Trouble diagnosis program for undercharge of battery**

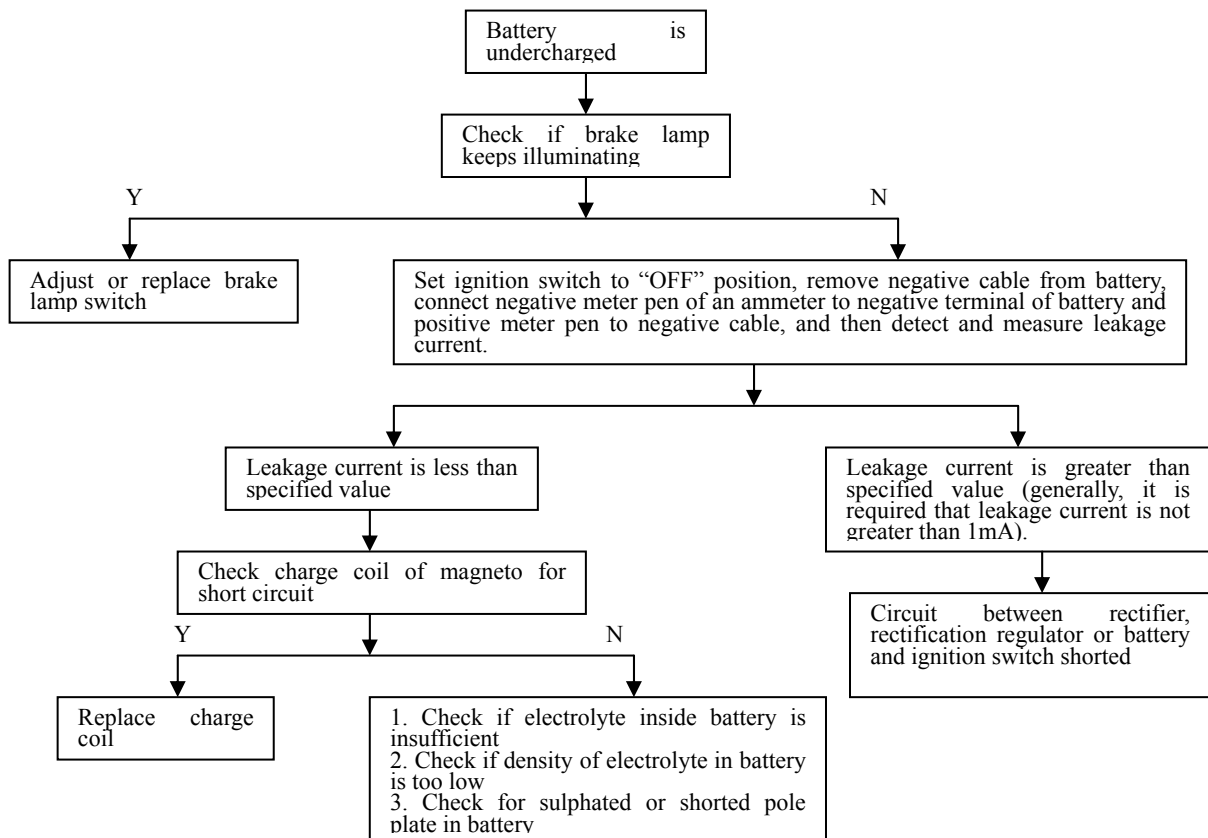

## Inspection/adjustment

Preparation of documents	Cylinder pressure
Check list of constant maintenance	Gear mobile oil
Engine mobile oil/oil filter	Changing gear oil
direction column bearing and handle fixing	Diving belt
Inspection/adjustment of accelerator's pull wire	Front/back brake free displacement
Air cleaner	The liquid volume examination of break fluid
Spark plug	Head lamp
Battery	Clutch
Carburator	Front/rear suspension system
Ignition timing	Bolt/nut/fixture
Rim/tyre	Tyre specification

## Preparation requirement

General

### Warning!

- Before starting engine, please confirm whether there is favorable ventilation and do not start engine in a closed location for that the exhaust gas contains carbon monoxide which may numb or kill people.
- Under certain condition, gasoline is prone to volatilize and explode so that the working place should be ventilated and kill the engine and should be free from smoking and lighting in the working area or oil storage. Please do not disconnect battery when you perform overall lineup; otherwise, internal damage of complete vehicle components may result.



## Specification

### Engine

Gyration speed at idle speed	1750±100rpm/min
Spark plug gap	0.6-0.7mm
Spark plug specification	BR7ES (NGK/TORCH)

### Carriage

Free stroke of front brake drawbar	10-20mm		
Free stroke of rear brake drawbar	10-20mm		
Tire pressure unit : Kpa	Specification		Tire pressure
	RACE 50	Outer cover of front wheel	120/70-12
		Front rim	3.50×12
	RACE 50	Outer cover of rear wheel	130/70-12
		Rear rim	3.50×12
Tire pressure	145-170kpa		
Tire pressure	170-195kpa		
Torque force value	front wheel-axle clamping nut	100-113 N·m	
	rear wheel fixed nut	100-113 N·m	

### Certification of related components

Sort	Name	Certification number
Tire	Outer cover of front wheel	E11 75R 000210
	Outer cover of rear wheel	E11 75R 000216
Light fitting	Head lamp	E4 0012026
	Tail lamp	E11 000054
	Front turn signal lamp	E3 001024

	Rear turn signal lamp	E3 001024
Rear-view mirror	Rear-view mirror	E3 001002
Horn	Horn	E4 000066
Reflector	Side reflector	E11 020614
	Rear reflector	E11 020613
Muffler	Muffler	EUR02-CAT

## Check list of constant maintenance

Inspection items	Mileage and time of maintenance							Tools
	Every 300 KM	Every 1000 KM	Every 3000 KM	Every 6000 KM	Every 12000 KM	Every 14500 KM		
	New motor cycle	One month	3 months	6 months	A year	15 months		
*	Air cleaner	I		C	C	R	C	General purpose tool
*	Gasoline filter	I			I	R		General purpose tool
*	Oil cleaner	C			C	C		General purpose tool
	Changing engine mobile oil	R	Changed every 1000KM					General purpose tool
	Tire pressure	I	I	I	I	I	I	Pressure meter, inflator
	Battery inspection	I	I	I	I	I	I	Gravimeter, universal meter
	Clearance inspection	I	I	I	I	I	I	General purpose tool
	examination on the tightness of direction handle	I			I	I		General purpose tool
	Shock absorber inspection	I			I	I		General purpose tool
	Bolt inspection	I	I	I	I	I	I	Torque spanner
	Oil leak inspection of gear case	I	I	I	I	I	I	General purpose tool
*	Spark plug inspection or replacement	I		I	R	R	I	General purpose tool
*	Replacement of gear case oil	I	Changed every 5000KM					General purpose tool
	Lubrication of each part				L	L		Lubrication filler
	Muffler	I	I	I	I	I	I	General purpose tool
*	Ignition timing	I	I	I	I	I	I	Timing lamp
*	Carburator	A	I	A	A	A	A	Tachometer, CO HC analyser
*	Inspection of idle speed and exhaust gas	A	I	A	A	A	A	
*	Accelerator inspection	I		I	I	I	I	General purpose tool
	Fuel line inspection	I		I	I	I	I	General purpose tool
	Lamplight, instruments, electric installations	I	I	I	I	I	I	Visual universal meter
	Main rack, side rack	I			I	I		General purpose tool
	Shock absorber			I	I	I	I	General purpose tool
*	Torque force of engine bolt	I		I	I	I	I	Torque spanner



## Pre-inspection

1	Ignition system - maintenance and inspection of ignition malfunction of distinct continuity, engine failed to start and superheat of afterburning.
2	Carbon laydown purging - purging the carbon laydown in the head of air cylinder, piston head and exhaust air system when the horsepower is in distinct deficiency.
3	Piston, air cylinder - excessive wear of air cylinder and cylinder smoothness, please replace.

Please be inspected at the dealer in Qianjiang regularly in order to keep motorcycle under its optimized condition.

The said table is based on that the motorcycle runs 1000km per month.

**I - inspection, A - adjustment, R - replacement, C - clean, L - lubrication**

### Remarks:

1. "\*" for the project of exhaust emission, according to the provisions of State Environmental Protection Administration of China, the maintenance should be implemented according to the specifications of the Instruction Manual of the Company and should not be adjusted or repaired without permission, otherwise the company will not take any responsibility.
2. If the motorcycle is driven on the sandstone road or under the environment of severe contamination, the times of purging air filtrator should be increased to prolong the service life.
3. For the motorcycle which is frequently driven at high speed or the milage is large the frequency of maintenance should be increased.

## Engine mobile oil/filtrator

### Mobile oil level

#### \*Attention

- The motorcycle of which the mobile oil is to be inspected should be done on the flat floor.
- After running 2-3 minutes, the engine should be stopped for 2-3 minutes for inspecting mobile oil level.

Inspect mobile oil level.

When the mobile oil level is below the lower limit, please supplement it up to the upper limit position.

1. Sump module
2. Sump cap module
3. Bolt M6×16
4. Oil sensor module
5. Clip 8

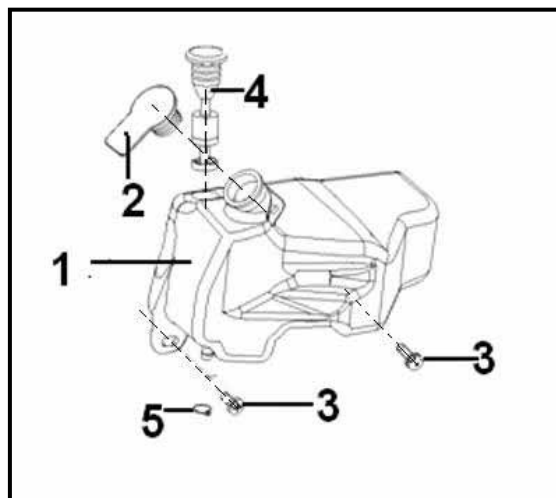

## Changing mobile oil

#### \*Attention

Change the mobile oil when the engine is warm for that it is easy to be effuse.

Kill the engine.

Dismantle the mobile oil drain bolt under the crankcase and discharge the mobile oil.

When the mobile oil is completely discharged, reinstall the mobile oil drain bolt and joint washer after cleaning.

Add mobile oil to specified volume.

Check mobile oil leakage; start engine at idle speed for several minutes.

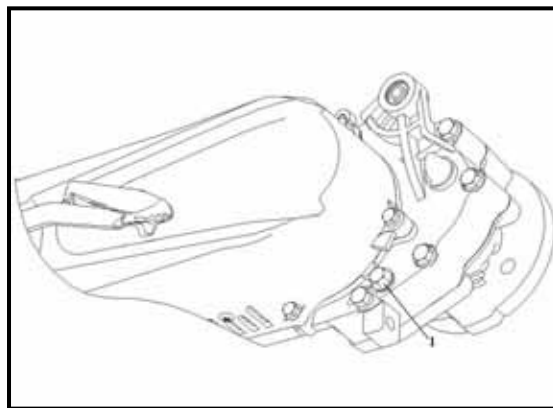

Reinspect mobile oil level.

## Inspection/adjustment of accelerator's pull wire

Check the smoothness of accelerator pull wire.  
 Examination of the free replacement of accelerator stayguy  
**Free displacement : 5-10mm**

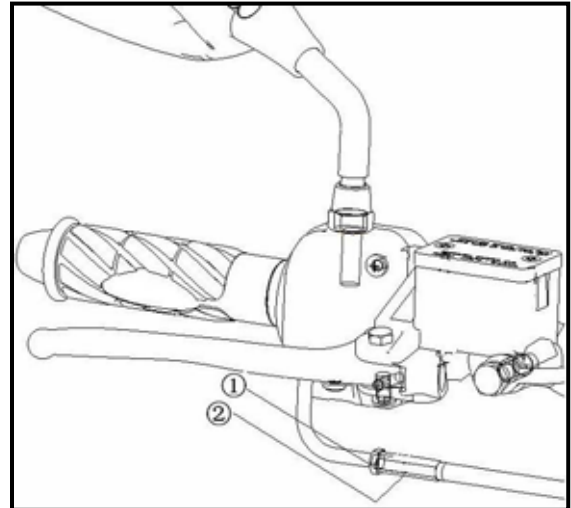

The main adjusting position is on the carburetor side.  
 Loosen the fixing nut and adjust by turning adjusting nut.

## Air cleaner

Replacement of the filterator  
 Remove body fender.  
 Remove fixing bolt (3) of air cleaner cover.  
 Remove pipe clip (4).  
 Remove the air filter.  
 Dismantle the clamping screw of the cover of air filter.  
 Take down the upper-cover of the filter.  
 Dismantle the filter element from the filter.

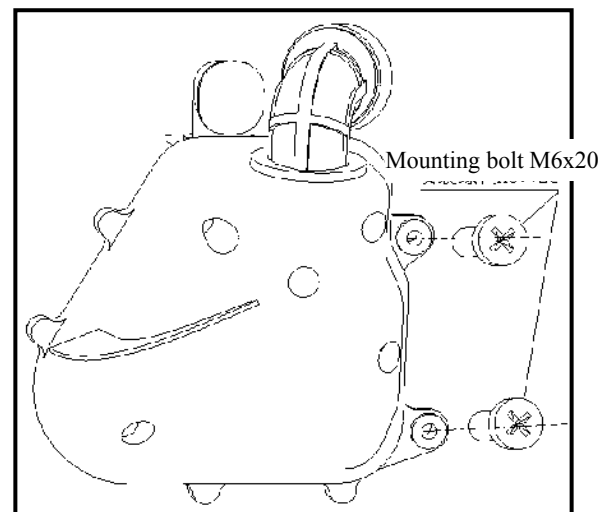

Check to see if the filter element is polluted or damaged.  
 If it is polluted or damaged, please replace with new one.  
 Dismantle the clamp component.  
 Remove the filter.  
 Check whether the filtrator is polluted or damaged.  
 If it is polluted or damaged, please replace with new one.

## Changing time

If the motorcycle is frequently driven on bad road or in rain,  
 it should be replaced early.

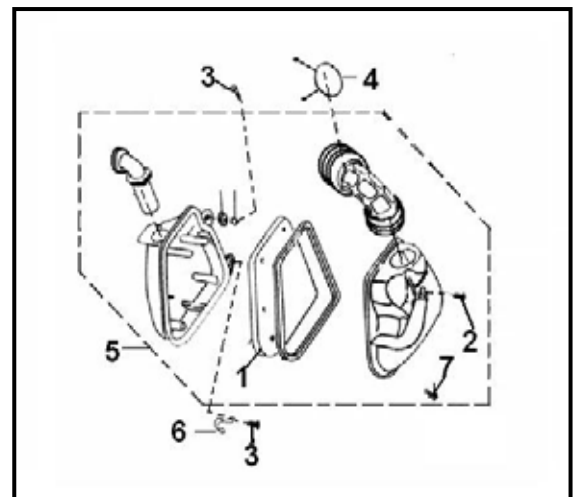

**\*Attention**

- Please confirm whether the air cleaner is installed as installing air cleaner cover.

## Spark plug

Dismantle spark plug.

Check the overburning, pollution and carbon laydown of spark plug.

If there is the said problem, please purge it with cleaner of spark plug or steel brush.

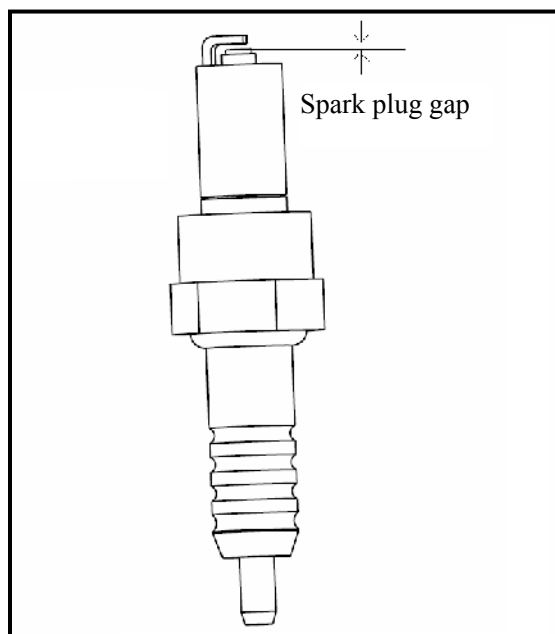

Inspection of spark plug gap

**Clearance : 0.6-0.7mm**

### \*Attention

As installing spark plug, please install it with hands and tighten by spark-plug socket.

## Battery

### Dismantle battery

Open the battery-cell lid.

Dismantle the clamping bar components of battery cell.

Dismantle the negative lead of prior to the positive lead.

Take out battery.

### Warning!

As dismantling positive pole, the tools should not contact the carriage in order to avoid short-circuit spark and igniting gasoline and the battery will be damaged that will be

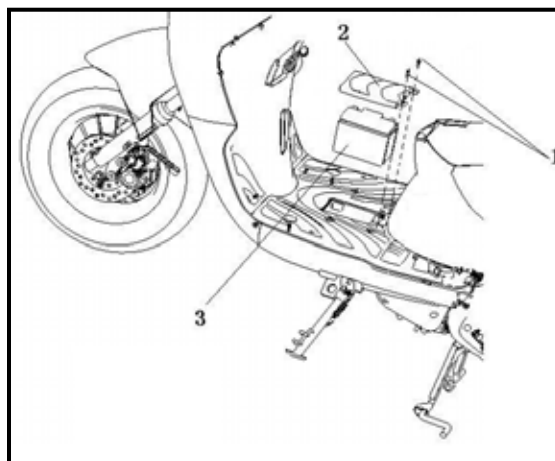

extremely dangerous.

The installation is in the reverse order of dismantling.

**Warning!**

In order to prevent short circuit, please connect positive pole prior to the negative one.

Please do not disconnect battery when you perform overall lineup; otherwise, internal damage of complete vehicle components may result.

**Inspection of charging state (CCU)**

Open the battery-cell lid.

Dismantle the clamping bar components of battery cell.

Remove the negative pole wire first, and then the positive pole wire.

Take out battery.

Measure the voltage between the battery terminals.

**Fully charged: 13.1V**

**Undercharge : 12.3V**

**\*Attention**

The inspection of charging state should be made by voltage meter.

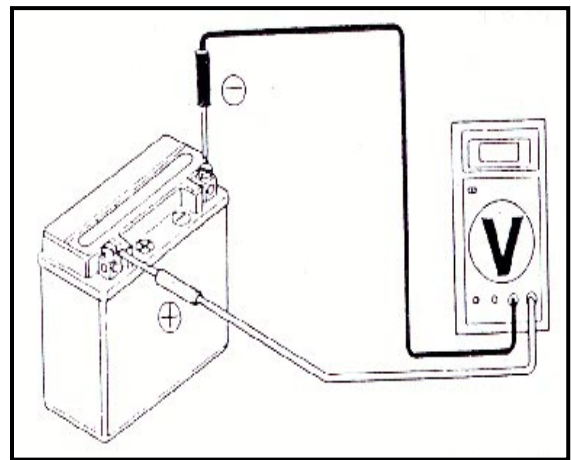

**Charging**

**Connecting method:**

**Connect the positive pole of charger to that of battery.**

**The negative pole of charge connects to that of battery.**

**Warning!**

- Fire should be strictly prohibited around battery.
- As starting to charge or upon the completion of charge, the switch of charger should be turned off first in order to prevent the spark of connecting position from explosion hazard.
- The current time specified on the battery should be the reference for charging.

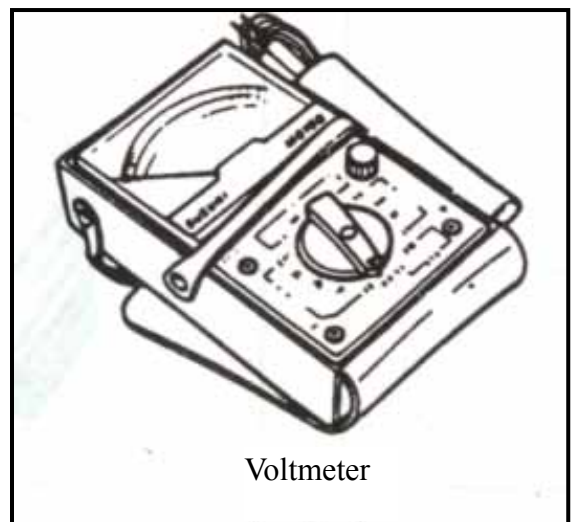

**\*Attention**

- If the storage cell is rapidly charged, it can not be used generally except in emergency.
- The voltage should be measured every 30 minutes after charging.

**Charging current :** standard : 0.4 A

**Quick : 4.0A**

**Charging period:** standard : 10 - 15 hours

**Quick : 30 minutes**

**Completion of charge: open-circuit voltage: above 12.8V**

## Carburator

### Idle adjustment

#### \*Attention

The idle adjustment should be made when the engine is warm.

It should be conducted after the warm-up of engine.

Start engine and connect the turnmeter of engine.

Adjust the accelerator pull wire and bolt stopper to specify the winding number.

#### Winding number at idle speed : $1750 \pm 100 \text{rpm/min}$

Readjust the idle adjustment bolt (2) when the gyration at idle speed is instable or there is difficulty of slight acceleration.

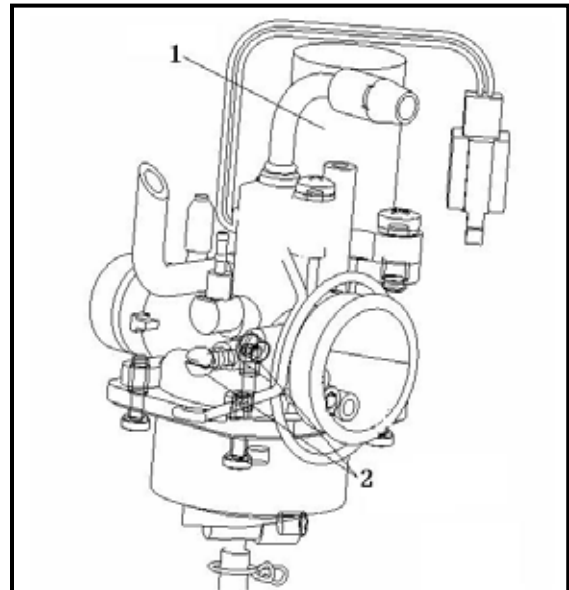

### Ignition timing

#### \*Attention

Warm up engine for 3~5 minutes.

Shut down engine and connect timing lamp to spark plug conductor.

\*Notice: Please refer to instructions for timing lamp before any operation.

Remove fender (1).

Start engine and idle it.

Check ignition timing.

If symbol "F" aligns with the mark symbol on right crankcase cover, it indicates that the ignition timing is correct.

Raise engine speed and check if symbol "F" starts to move.

#### Idle speed : $1750 \pm 100 \text{rpm/min}$

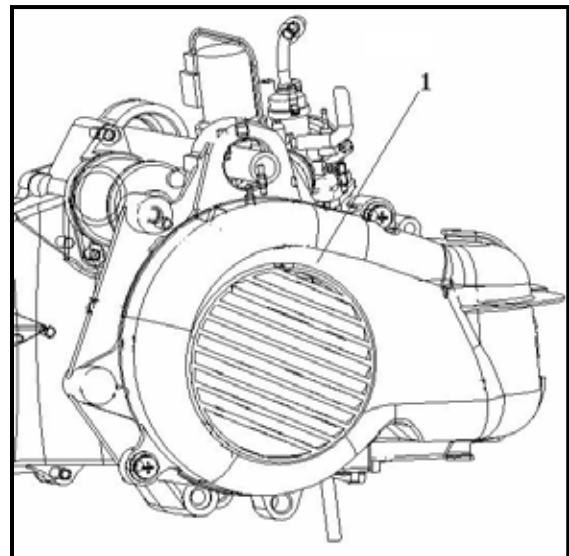

### Cylinder pressure

It should be made when the engine is warm.

Remove the guard plate of car body.

Dismantle spark plug.

Install cylinder pressure meter.

Full throttle, press "Start" to run motor and measure the cylinder pressure.

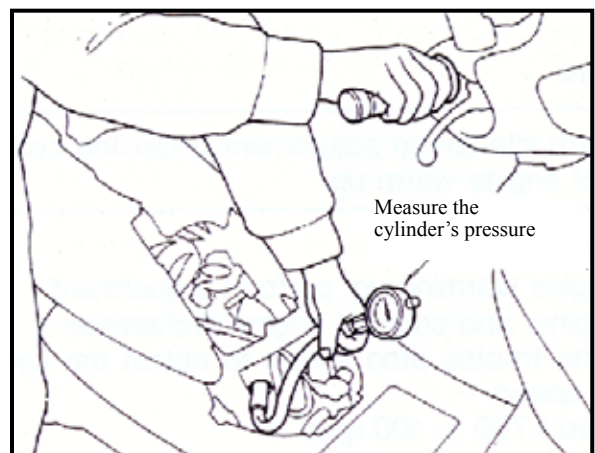

Check the following items if the compression pressure is too low:

- Cylinder head gasket is damaged
- Damage of piston ring
- Ring wear
- Piston , cylinder , valve wear

Check the combustion chamber and the carbon laydown on the top of piston if the compression pressure is too



high.

## Gear mobile oil

### Inspection

#### \*Attention

Fuel check, let down the middle supporter to be perpendicular to motorcycle on the flat floor.

Dismantle the inspection bolt of gear oil after stopping engine. ( 1 ) .

The oil level is below the lower limit of bolt hole is good.  
Please supplement gear oil when the oil level is too low.  
Install the inspection bolt of gear oil.

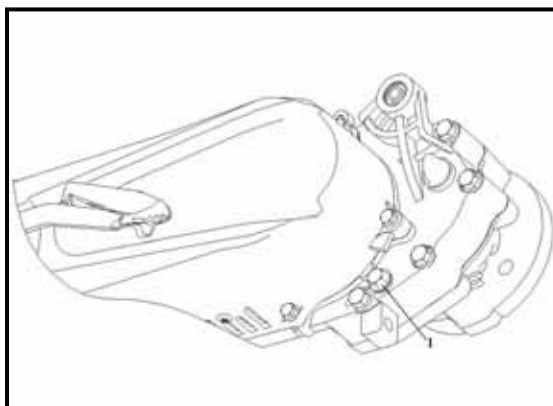

#### \*Attention

Confirm the airtightness of bolt and whether it is out of clutch and damage.

## Changing gear oil

Dismantle the inspection bolt of gear oil.

Dismantle the oil drain bolt ( 1 ) , the gear oil will effuse.

Install the oil drain bolt.

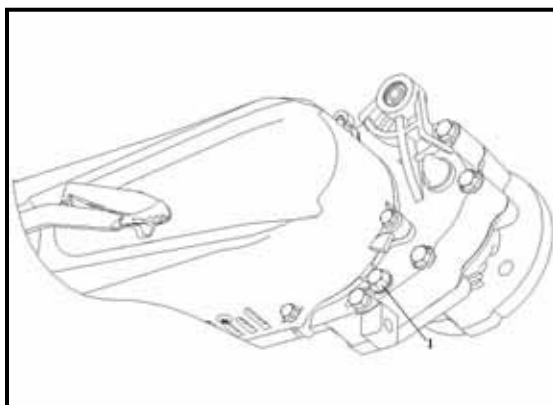

#### \*Attention

Confirm the airtightness of bolt and whether it is out of clutch and damage.

Supplement gear oil.

Check the oil leak of each position after operation.

Install the inspection bolt of gear oil.

## Driving chain

Dismantle the left crankcase lid.

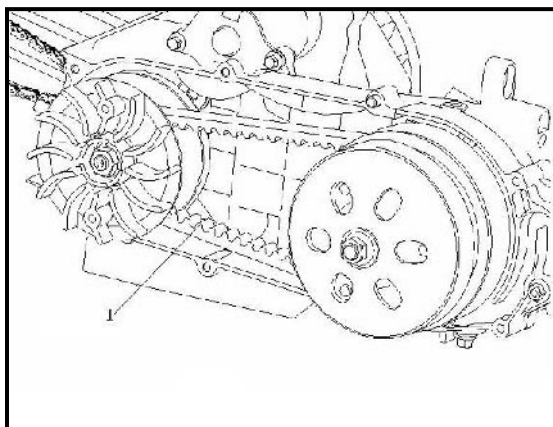

Check to see if the driving belt is broken or worn out.  
Replace for new products when necessary or periodically.

### Free displacement of the front/rear brake

#### Free displacement of the front brake

Measure the free displacement of the front brake handle at the tip of the brake handle.

**Free displacement: 10-20mm**

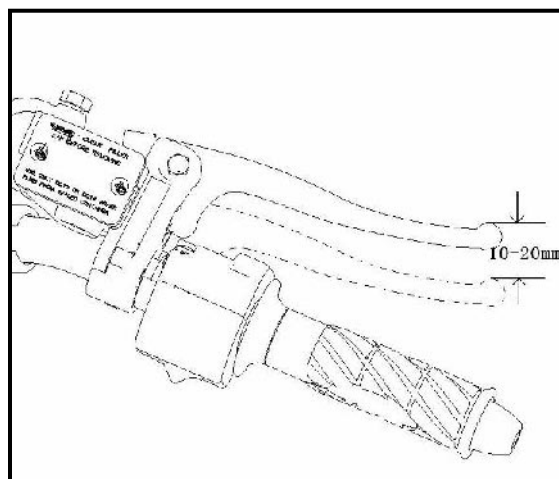

#### Free displacement of the rear brake

Measure the free displacement of the rear brake handle at the tip of the brake handle.

**Free displacement: 10-20mm**

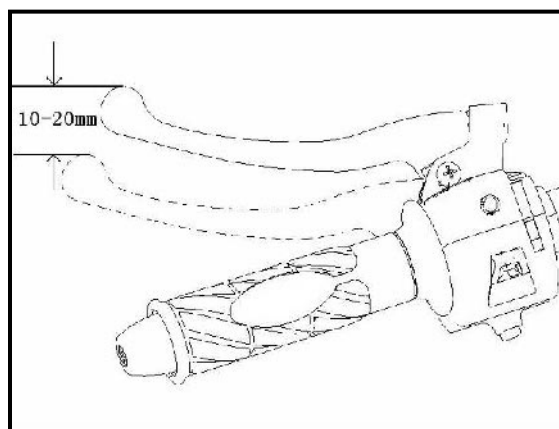

### Examination on the liquid amount of the brake liquid

When braking to its end, check up the oil amount through the oil lens. If the liquid level of the brake fluid is vertical to or is lower than the graphic arrow, brake liquid should be injected in till the ceiling level.

**Note:**

During the examination, the oil pump body should be parallel with the surface.

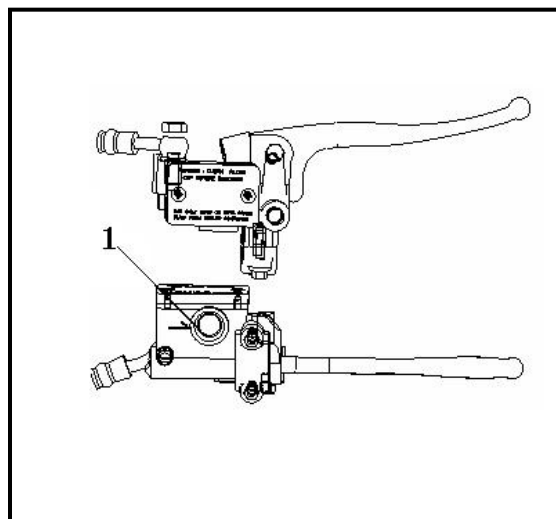

### Head lamp

Remove the front cover.

Cut off the switch connector of the head lamp.

Remove the head lamp.

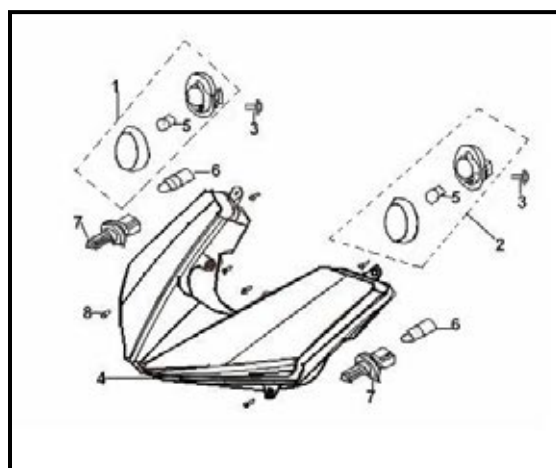

## Clutch

Start engine and increase the winding number slowly to inspect the actuation of clutch and check the clutch block if the motorcycle does not move or the engine misses.

Replace the new part if necessary.

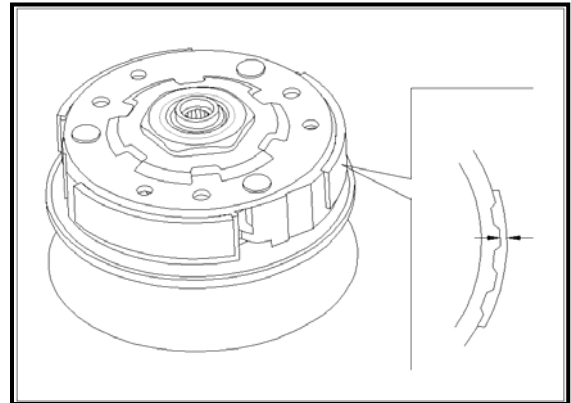

## Front/rear suspension system

### Front

Strain the front brake and compress the front shock absorber up and down to check the actuation.

Check whether the front shock absorber is leak and each part is

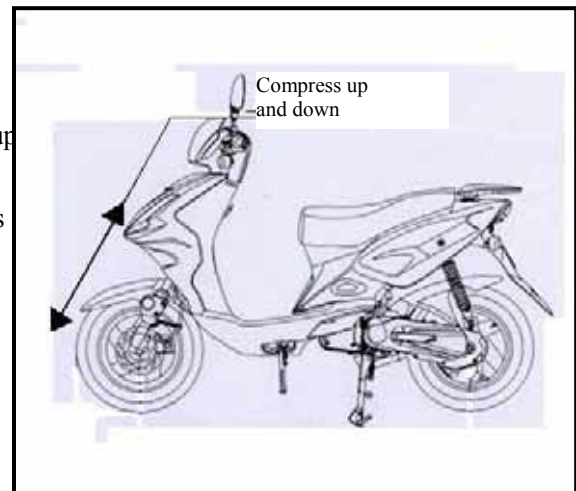

### Rear

Compress the rear shock absorber up and down to check the actuation.

Check whether each part of the rear shock absorber is damaged or loosened.

Suspense the rear wheel and swing it to check whether the engine suspension bush is loosened.

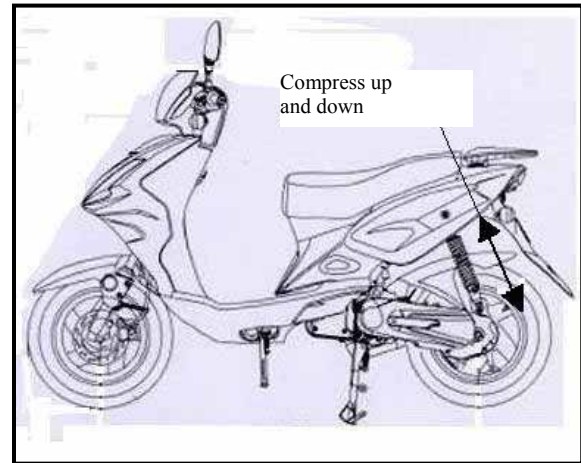

### Nut/bolt/fixture

Check whether the bolt, nut and fixture of the motorcycle is loosened.

If so, please tighten to specified torque force value.

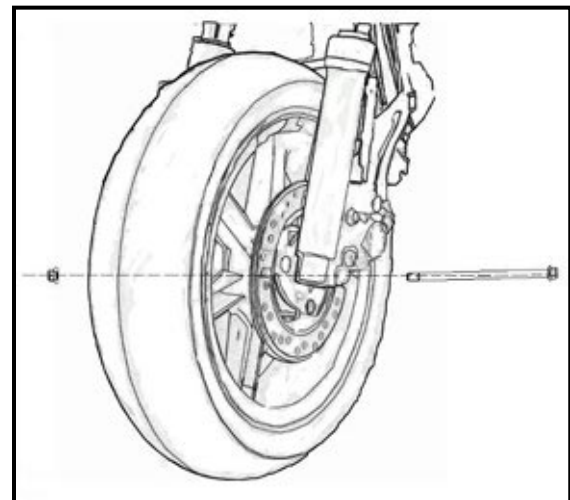

### Rim/tyre

Check whether there is crack, nail or other damage of the tyre.

Check the tyre pressure.

#### \*Attention

The tyre pressure should be measured under cold condition.

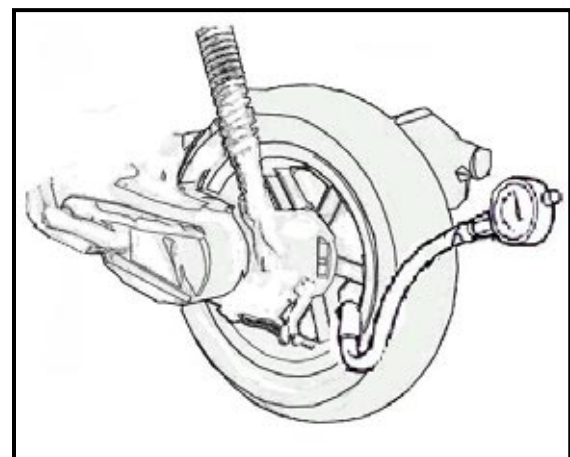







## Inspection and Service of Electrical System

**Table of Torques for Fasteners in Electrical System**

<b>Fastening location and name of fastener</b>	<b>Tightening torque (N·m)</b>
<b>Starting motor clutch cover bolt</b>	<b>12</b>
<b>Fixing nut of starting motor clutch cover</b>	<b>95</b>
<b>Rectifier bolt</b>	<b>5.0</b>
<b>Fixing bolt of ignition coil</b>	<b>9.0</b>
<b>Fixing nut of flywheel</b>	<b>5.0</b>
<b>Body fender bolt</b>	<b>9.0</b>



# Charging system

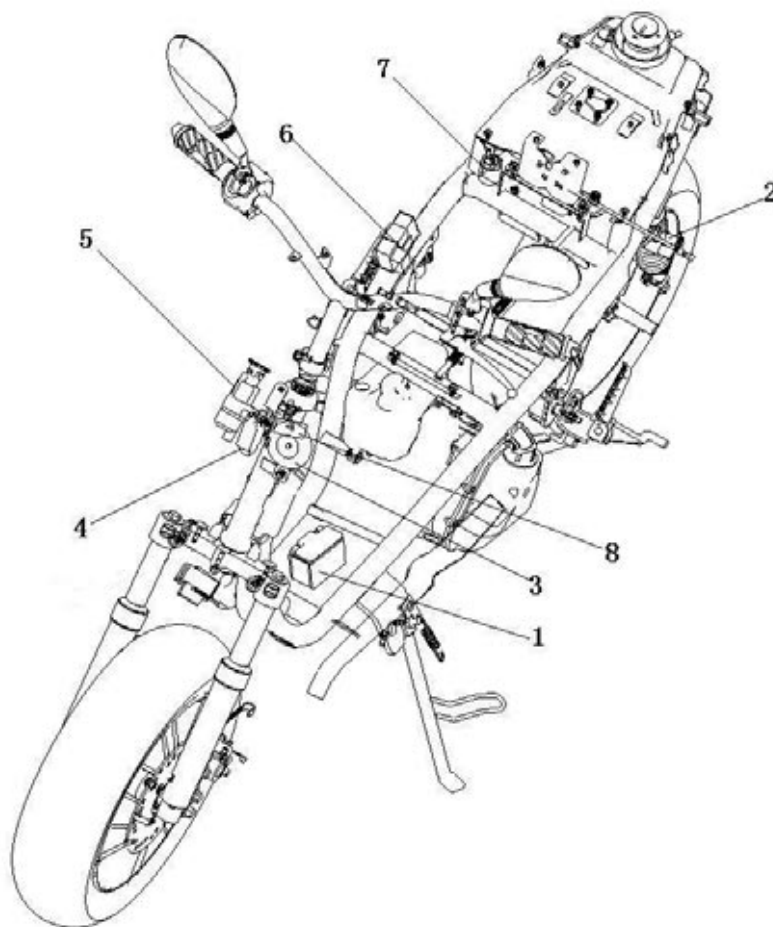
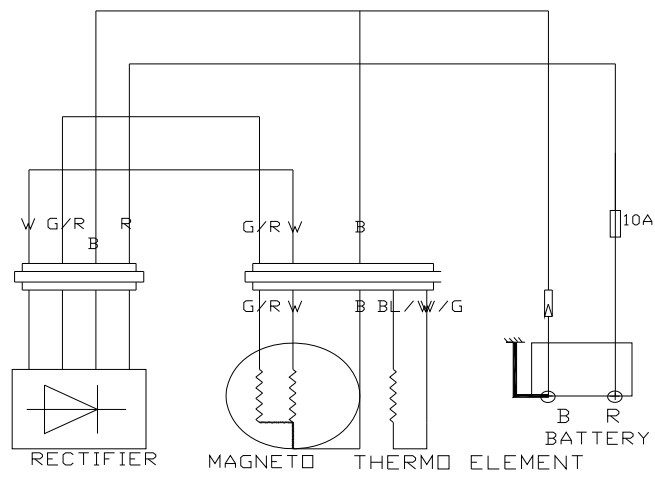



1. Battery 12V, 4AH    2. Cushion lock module    3. Horn    4. Rectifier    5. Power lock module    6. Igniter  
7. Relay    8. Release resistor

# I. Battery/charging system

Preparation data -----1.1	Fault diagnosis -----1.2
Battery -----1.3	Charging system -----1.4
Voltage and current regulator -----1.5	Charge coil of the alternator ---1.6
Disassembly of alternator -----1.7	

## 1.1 Preparation data

### Matters needing attention in operation

#### \* Note

1. The battery can be charged and discharged over again. If the battery is unused after discharge, the service life will shorten and the performance will degrade. Generally, performance of the battery used for 2 or 3 years will degrade. Such battery( capacity declined )may restore its voltage after charging but the voltage will drop off rapidly when loaded.
2. Surcharge of battery : generally surcharge can be observed from the battery proper. If the battery is cut short inside, no voltage can be tested at the terminal of the battery or the voltage is very low. Invalidation of the regulator : the battery will have too high voltage, which may shorten its service life.
3. Long rest of the battery will result in self discharge and the electric capacity will reduce, therefore, it must be charged every 3 months.
4. Inspect the charging system in accordance with the order stipulated in the fault diagnosis table.
5. If there is electric current passes through an electrical unit, do not disassemble the connector, otherwise, overtension will occur which can damage the electronic parts inside the voltage regulator. The main switch must be pushed to "off" before any operation.
6. Maintenance free ( dry charged type ) battery does not need inspection, replenish of electrolyte solution or distilled water.
7. Inspect the entire power load.
8. Emergency charging cannot be used except in contingency situations.
9. In emergency charging of the battery , it must be unloaded from the motorcycle before charging.
10. Please do not use liquid type battery when exchanging batteries.
11. A voltage meter must be used when inspecting the charging conditions.

## Preparation reference

Item		Specification	
Battery	Capacity/ type	12V-4AH/ charge type	
	Voltage ( 20°C )	Fully charged	13.1V
		Must be charge	12.3V(not work for an hour)
	Charging current	Standard : 0.4A , Fast : 4A	
	Charging time	Standard : 10-15h , Fast : 30m	
Magneto	Capacity	90W/8000rpm	
	Impedance value of lighting coil (20 $\square$ )	Between green/red and black 2.0-2.5 $\Omega$	
	Impedance value of charge coil (20 $\square$ )	Between white and black 1.5-2 $\Omega$	
Voltage regulator	Type	Single-phase half-wave SCR charge; SCR half-wave short circuit method	
	Voltage limit	Lighting limit	14.0V $\pm$ 0.4V/5000rpm
		Charge limit	13.5V/5000rpm
		14.8V $\pm$ 0.4V/5000rpm	

### Torque value

Rectifier bolt	5.0 N·m
Fixing bolt of high tension coil	9.0 N·m
Flywheel fixed nut	5.0 N·m
Car body guard plate bolt	9.0 N·m

### Tools

Multiple-use fixing spanner
Flywheel dissembler
Testing instrument
Avometer

## 1.2 Fault diagnosis

### No power supply

Over-discharge of battery  
 Battery wire not connected  
 Fuse blown  
 Bad act of power switch

### Low voltage

Battery badly charged  
 Poor contact  
 Bad act of charging system

### Discontinuous current

Poor wiring contact of battery  
 Poor contact of discharge system  
 Poor contact or short circuit in lighting system

### Bad act of charging system

Poor contact , short line or short circuit of wire terminal  
 Bad act of voltage and current regulator  
 Bad act of alternator

Bad act of voltage and current regulator

## 1.3 Battery

### 1.3.1 Disassembly of the battery

Open the battery-cell lid.

Dismantle the clamping bar components of battery cell.

Disassemble the negative wire and then the positive wire.

Take out the battery.

#### **Warning!**

In the disassembly of positive pole the tools mustn't contact the frame because the short-circuit spark will ignite gasoline and damage the battery.

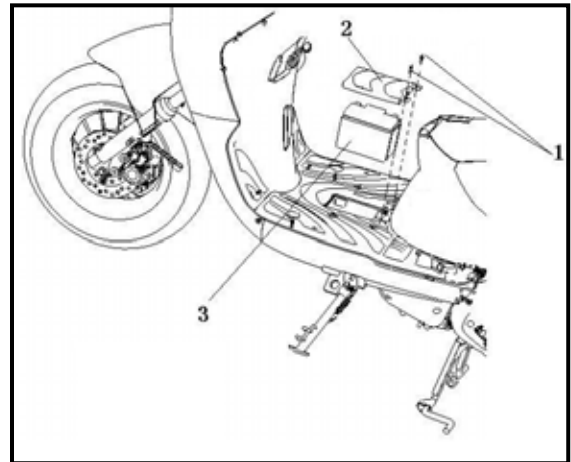

Installation is conducted in the reverse order of disassembly.

#### **\*Attention**

In order to prevent short circuit, connect positive pole first before the negative pole.

Please do not disconnect battery when you perform overall lineup; otherwise, internal damage of complete vehicle components may result.

Inspect the charging state ( open-circuit voltage ) .

Open the battery-cell lid. Dismantle the clamping bar components of battery cell.

Remove the joint wire of storage cell.

Measure the voltage between battery terminals.

**Fully charged : 13.1V**

**Undercharged : 12.3V ( The battery does not work for an hour )**

#### **\*Attention**

Inspection of charging state must be performed with a voltage meter.

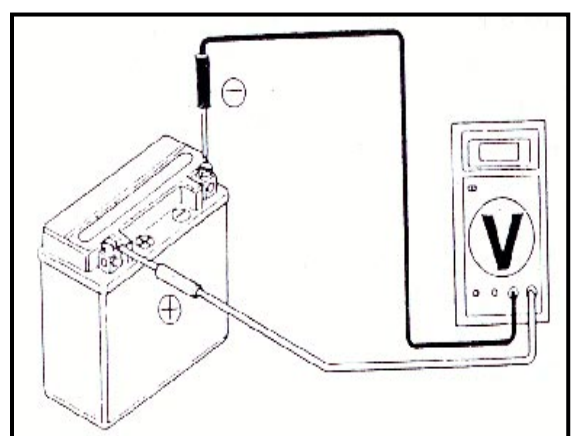



## 1.3.2 Charge

### Connecting method :

Connecting the positive pole of charger and the positive pole of battery.

Connecting the negative pole of charger and the negative pole of battery.

### Warning !

- Keep the battery away from ignition sources.
- Shut off the charger first once charge is started or finished so as to prevent explosion hazard caused by flashes at the interconnecting part.
- Charge operation must follow the marked time on the battery.

### \*Attention

- Fast charging cannot be used except in contingency situations.
- Do not measure the voltage until 30 minutes after the charge.

**Charging current : Standard : 0.4 A**

**Fast : 4.0A**

**Charging time : Standard : 10-15h**

**Fast : 30m**

**Charge completed : open-circuit voltage : 12.8V or above**

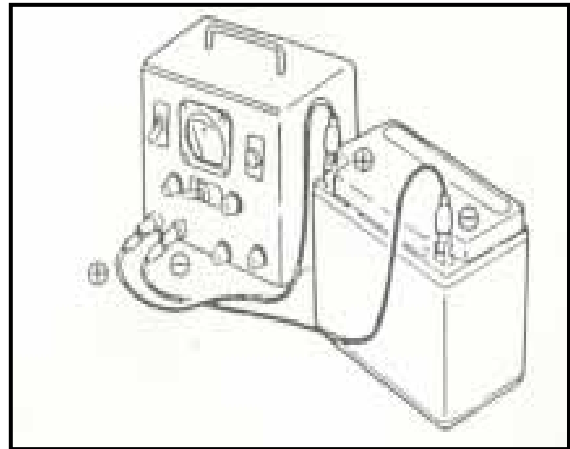

## 1.4 Charging system

### 1.4.1 Short circuit test

Remove the ground wire off the battery, connect the voltmeter between the battery negative pole and ground wire with the switch at OFF and inspect whether there is short circuit.

### \*Attention

Connect the positive pole of avometer with the negative pole of battery.

If there is any disorder, please inspect whether the main switch and main wire are in short circuit condition.

### 1.4.2 Inspect the charging state

Test with an avometer when the battery is fully charged. Mount the fully charged battery after the engine warms up. Connect a voltage meter between the battery terminals. Connect an amperemeter at the position where two terminals

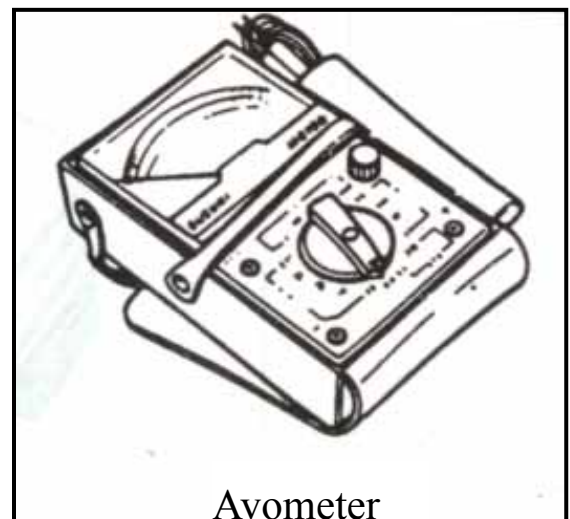

Avometer

are disassembled to the main fuse.

Start the engine and measure the clamping voltage and current when the rotation speed gradually increases.

**Clamping voltage/rotation speed : 14-15V ( 2500rpm )**

If the clamping voltage exceeds the specified value range, inspect the voltage regulator.

Inspect the clamping voltage of the lighting system.

**\*Attention**

Set the avometer at the alternating voltage position.

**Clamping voltage : 13.1±0.5V/2500rpm**

If the clamping voltage exceeds the specified value range, inspect the voltage and current regulator.

## 1.5 Voltage and current regulator

### 1.5.1 Inspect the main wire circuit

Disassemble the 4P plug of the voltage and current regulator.

Inspect the conduction between main wire terminals with the following methods.

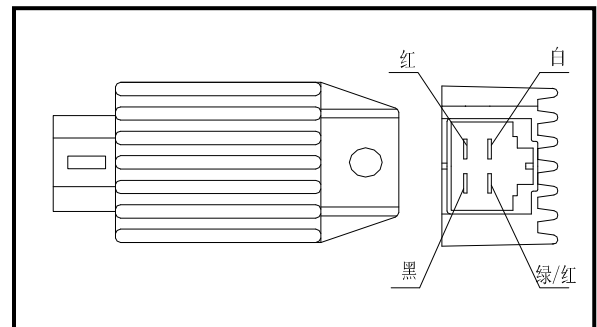

Item ( wire color )	Judging method
between the battery ( red ) and body ground	there being battery voltage
between the ground wire ( black ) and body ground	there being wire
between the charge coil ( white ) and body ground	there being resistance in alternator coil
After checking that the main wiring end between illuminating line (green/red) and body ground (resistor plug; plug of automatic side starter; remove lighting switchboard and check in OFF position) is completely normal.	there being resistance in alternator coil

Multitester	White ( A )	Green/red ( L )	Red ( B )	Black ( E )
r				
+	Unit : MΩ			
-				
Green/red	1~10	0	6.5 24~25	19~21 19~23
White				

## 1.5.2 Inspect the voltage and current regulator

Check plug of voltage and current regulator for poor contact and measure impedance values between terminals on voltage and current regulator body.

### \*Attention

- The metal area of the avometer prod mustn't be touched by fingers during inspection.
- Inspect with an avometer. Different avometers will give different resistance values, and the inspection result is incorrect.

If the resistance value between terminals is abnormal, the voltage regulator should be replaced.

( L )				
Green( B )	10~50	0		19~21
Black( E )	5~15	0	0	

## 1.6 Charge coil of the alternator

### \*Attention

Inspection of the charge coil of alternator may be conducted on the engine.

### Inspection

Disassemble the 6P joint of alternator.

Measure the resistance value between the white coil of alternator and the motorcycle frame with an avometer.

**Standard value : 1.5-2Ω ( 20°C )**

If the measured value exceeds the standard value, replace the alternator coil.

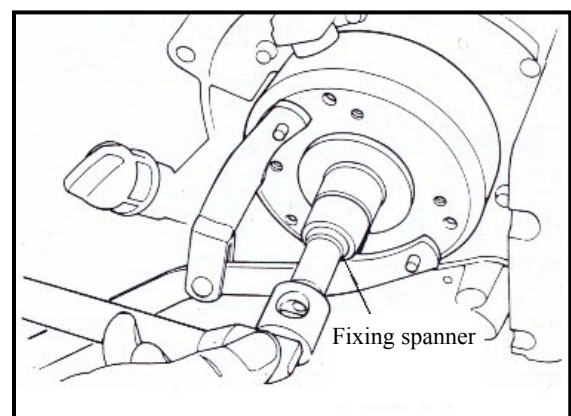
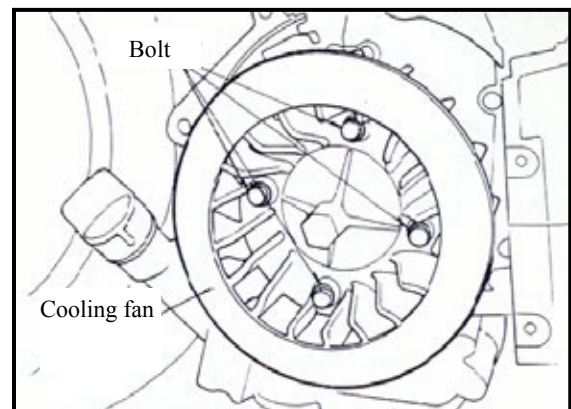

## 1.7 Disassembly of alternator

### \*Attention

Inspection to lighting coil of magneto can be performed on engine.

### 1.7.1 Inspection

Remove 3P joint of magneto.

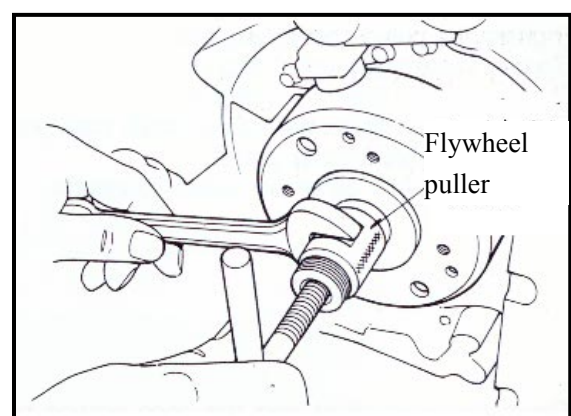

Use a multimeter to measure the impedance value between green/red wire on magneto and body ground.

**Standard value : 2.0-2.5Ω ( 20°C )**

When the measured value exceeds the standard value, replace the magneto coil.

## **1.7.2 Disassembly**

Disassemble the body guard.

Remove right body fender.

Remove fixing bolts and screws and take off fan cover.

Remove 4 fixing bolts of cooling fan to take the latter off.

Fix the flywheel with a multiple use fixing spanner.

Disassemble the flywheel fixing bolt.

Remove the flywheel with a flywheel puller.

Disassemble the retaining key.

Disassemble the lead connector of the alternator.

Disassemble the alternator stator.

### 1.7.3 Installation

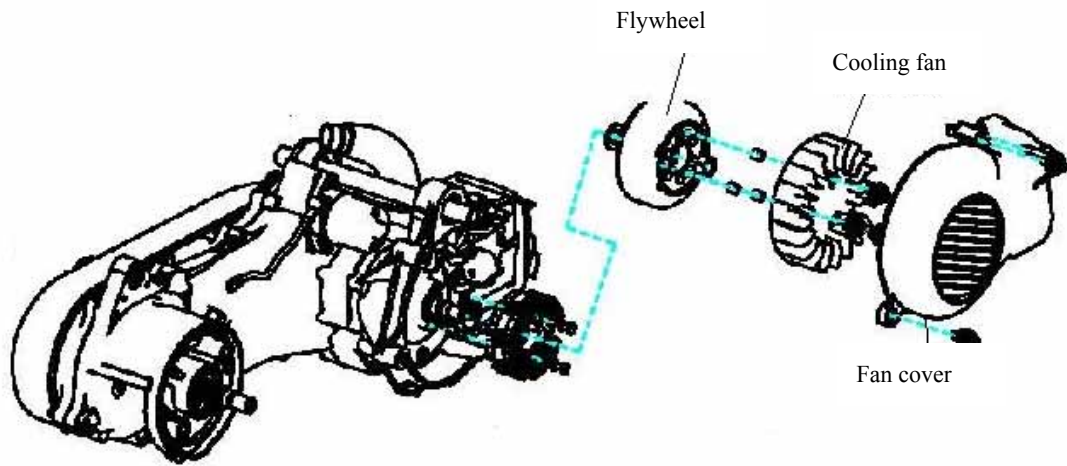

Install magneto stator on engine case.  
Connect wire terminals of magneto.

Clean the tapered part of the crankshaft and flywheel.  
Install the retaining key of flywheel in the key groove on the crankshaft and confirm.  
Align the flywheel groove with the retaining key of the shaft.

**\*Attention**

Confirm no bolts are on the inner face of the flywheel because of magnetism of the inner face.

Fix the flywheel with a multiple use fixing spanner and screw the fixing nut.

**Torque value : 9.0 N·m**

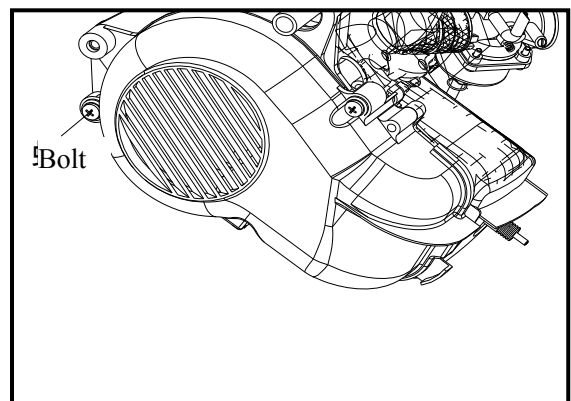

Install the left body guard.

## Ignition system

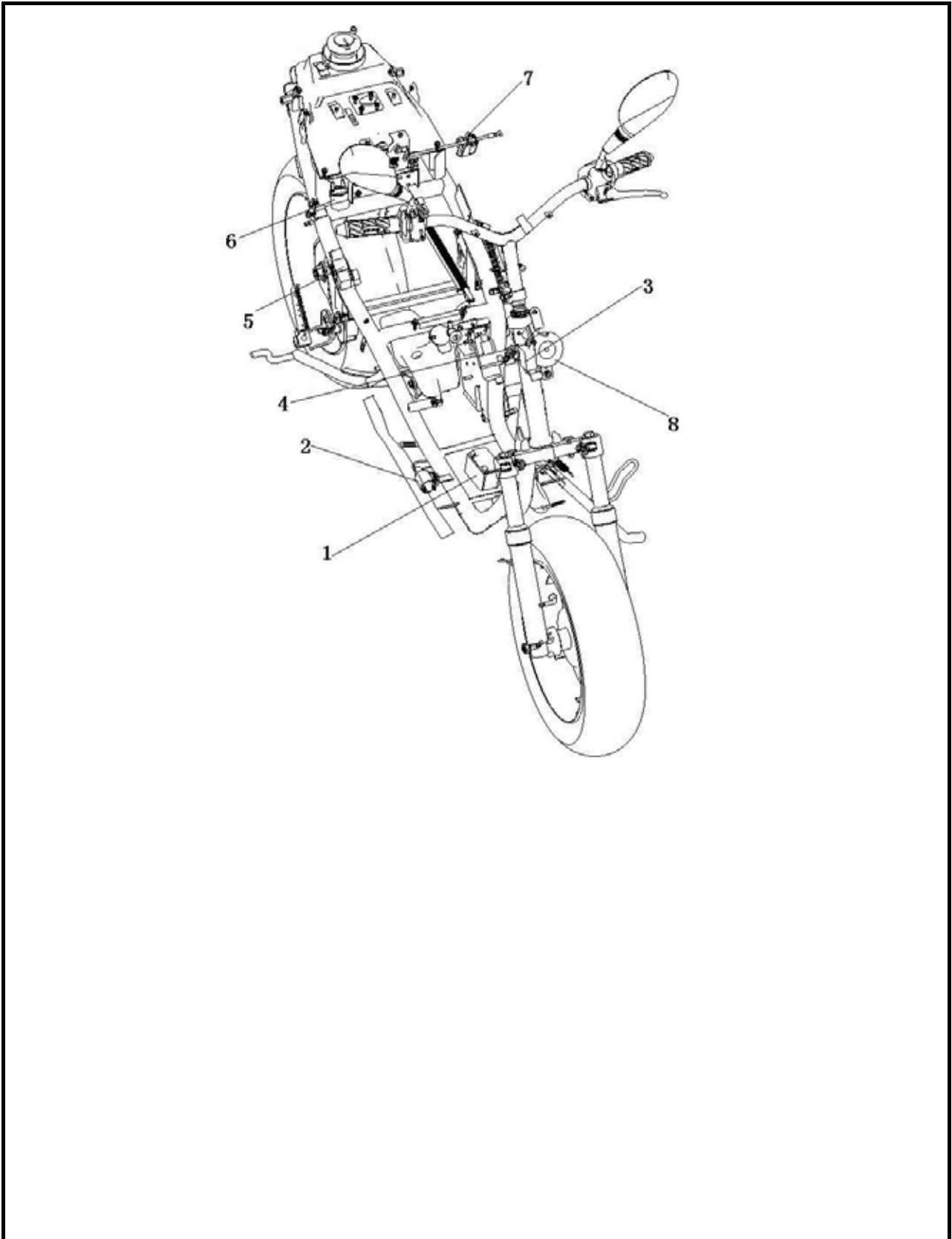

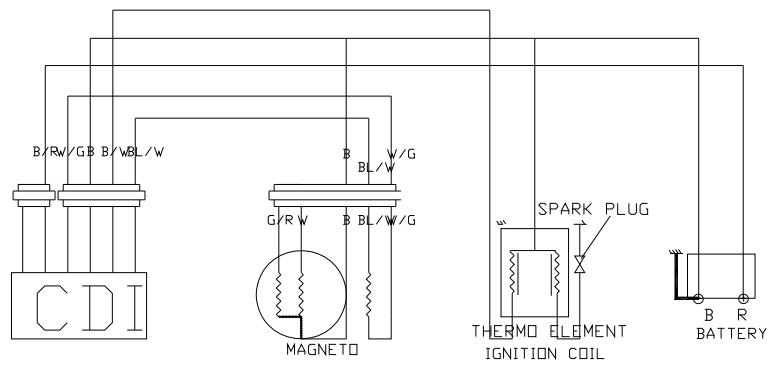

Ignition system

1. Battery 12, 4AH
2. Ignition coil assembly
3. Rectifier
4. Power lock module
5. Igniter
6. Relay
7. Cushion lock module
8. Horn

## II. Ignition system

Preparation data -----	2.1	CDI group -----	2.4
Fault diagnosis -----	2.2	Ignition coil -----	2.5
Ignition system inspection -----	2.3	Trigger -----	2.6

### 2.1 Preparation data

#### Matters needing attention in operation

1. Inspect the ignition system in accordance with the order stipulated in the fault diagnosis table.
2. The ignition system is an electronic auto-advance device integrated in the CDI group, therefore the ignition time needs no adjustment.
3. Inspect the ignition system in accordance with the order stipulated in the fault diagnosis table.
4. Take particular care in disassembly that the CDI group of ignition system should not fall off and drop down or should not be stricken with might ( which is the main cause of fault )
5. Bad socket contact is the main cause of the ignition system fault, so inspect whether the joint of each part is in poor contact or not.
6. Inspect whether the spark plug is utilized at a proper thermal value. Improper spark plug may lead to unsmooth operation of engine or burn-out of the spark plug.
7. Inspection in the chapter is based on explanation of peak voltage and the judgment whether the resistance value of ignition coil is OK or not according to records after the inspection.
8. Inspection of the main switch should be performed in accordance with the conduction table.
9. The disassembly of the alternator and stator should be conducted in accordance with the disassembly explanation.

#### Preparation reference

Item		Standard value	
Recommended spark plug	Standard	C5HSA(NGK)	
	Hard plug	C6HSA(NGK)	
	Soft plug	C7HSA(NGK)	
Spark plug gap		0.6-0.7mm	
Resistance value of ignition coil ( 20℃ )	Primary coil	0.6Ω±10%	
	Secondary coil	With spark plug cover	5-11KΩ
		Without spark plug cover	0.5-5.5KΩ
Resistance value of the trigger ( 20℃ )		100-500Ω	
Measured peak voltage of ignition coil at one go		95-400V	
Trigger voltage		Above 1.7V	
Voltage of charge coil		95-400V	

#### Tools

Accessory of peak voltage meter



Avometer

## 2.2 Fault diagnosis

### No flashover in spark plug

	Abnormal circumstance	Cause of badness ( confirm in order from 1 )
ignition coil	high voltage too low	<input type="checkbox"/> The interior resistance is too low and test it with a designated tester. <input type="checkbox"/> The cranking speed is too low. <input type="checkbox"/> The tester is disturbed ( if the voltage measured for several times is above standard, then the value is normal ) . <input type="checkbox"/> poor contact of ignition system wire <input type="checkbox"/> bad act of the ignition coil <input type="checkbox"/> bad act of the charge coil ( peak voltage test)
	no high voltage , off-and-on high voltage	<input type="checkbox"/> connecting error in tester <input type="checkbox"/> bad act of the main switch <input type="checkbox"/> poor contact of CDI joint <input type="checkbox"/> short circuit or poor contact of CDI ground wire <input type="checkbox"/> bad act of charge coil ( peak voltage test ) <input type="checkbox"/> bad act of trigger ( peak voltage test ) . <input type="checkbox"/> bad act of connector for high voltage wire <input type="checkbox"/> bad act of CDI group ( when item□-□ is abnormal or when there is no spark in the sparkplug )
	Normal high voltage, no spark	<input type="checkbox"/> bad act of spark plug or power leak in secondary coil <input type="checkbox"/> bad act of ignition coil
charge coil	no high voltage	<input type="checkbox"/> The interior resistance is too low. Test it with a designated tester. <input type="checkbox"/> The cranking speed is too low. <input type="checkbox"/> The tester is disturbed ( if the voltage measured for several times is above standard, then the value is normal ) . <input type="checkbox"/> bad act of the charge coil ( no abnormality in Item □-□ )
	no high voltage , off-and-on high voltage	<input type="checkbox"/> bad act of the ignition coil <input type="checkbox"/> bad act of the charge coil
trigger	high voltage too low	<input type="checkbox"/> The interior resistance is too low and tests it with a designated tester. <input type="checkbox"/> The cranking speed is too low. <input type="checkbox"/> The tester is disturbed ( if the voltage measured for several times is above standard, then the value is normal ) . <input type="checkbox"/> bad act of the charge coil ( no abnormality in Item □-□ )
	no high voltage , off-and-on high voltage	<input type="checkbox"/> bad act of the ignition coil <input type="checkbox"/> bad act of the trigger



## 2.3 Ignition system inspection

### \*Attention

- When there is no spark in the spark plug , inspect whether the wire or part is loosen or in poor contact and confirm whether each voltage value is normal.
- Since there are a great many of avometer brands with different interior resistance, the values tested will differ accordingly.

Connect the avometer with a high voltage diverter or an electric meter with input resistance above 10MΩ10CV.

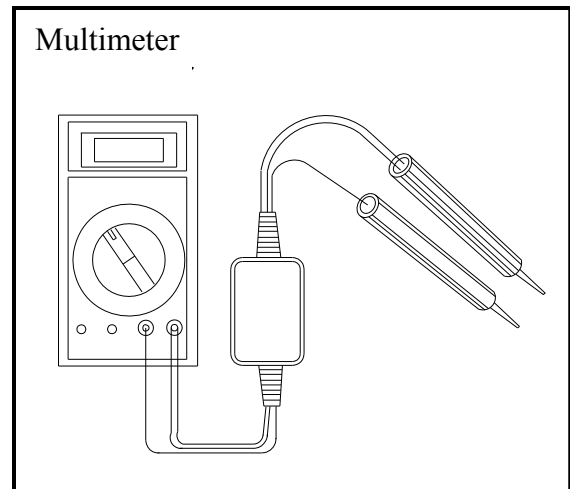

### 2.3.1 Primary voltage of ignition coil

Replace the spark plug with a good one and connect it with the engine.

### \*Attention

Correctly connect each circuit before the test.  
Normal compression pressure of the air cylinder is achieved in the test when the spark plug is installed on the cylinder head.

Connect the wire of ignition coil and connect the primary coil terminal( black / white ) with the diverter at the Ground. Press the startup electrical machinery or step on the actuating lever to measure the primary peak voltage of the ignition coil.

**Minimum voltage : 95 V or above.**

### \*Attention

The metal area of the avometer prod mustn't be touched by fingers to prevent electroshock.

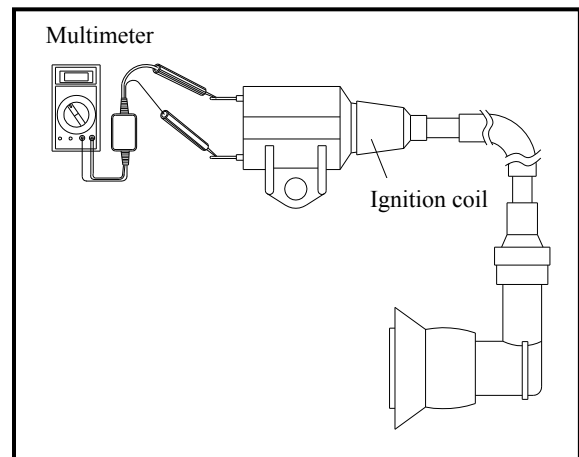

Remove the 4P and 2P joint of CDI group, and connect a High Voltage diverter between the charge coil of the 2P joint ( red / white terminal ) to the wire and the 4P joint ( black terminal ) .

Press the startup motor or step on the actuating lever to measure the peak voltage of the charge coil.

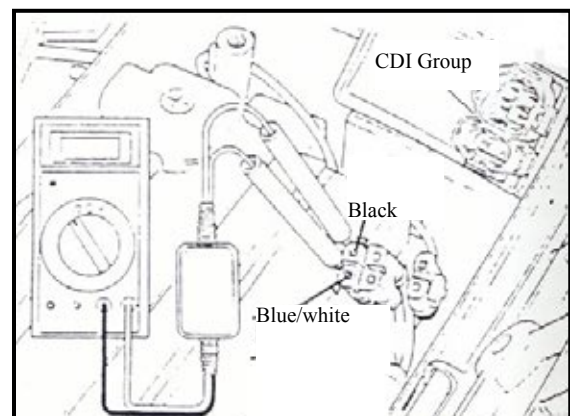

## 2.3.2 Trigger

### \*Attention

Install the spark plug on the air cylinder head and inspect with normal compression pressure.

Remove the 6P joint of CDI group, and connect a peak voltage diverter between the trigger of 6P joint ( blue/white terminal ) to the wire and the 4P joint( black terminal ). Press the startup electrical machinery or step on the actuating lever to measure the peak voltage of the trigger.

Connecting method: positive pole connected with blue/white line, and negative pole connected with black line.

**Minimum voltage : 1.7V or above.**

### \*Attention

The metal area of the avometer prod mustn't be touched by fingers to prevent electroshock.

If the peak voltage of the CDI terminal has an abnormal value, disassemble the right body guard and the alternator joint.

Connect the trigger ( blue / white ) with the diverter.

- If the tested voltage of CDI is abnormal whereas the tested voltage at the alternator is normal, poor contact or broken line can be determined.
- If both are abnormal, bad act of the trigger can be determined. Please refer to inspection of the troubleshooting table.

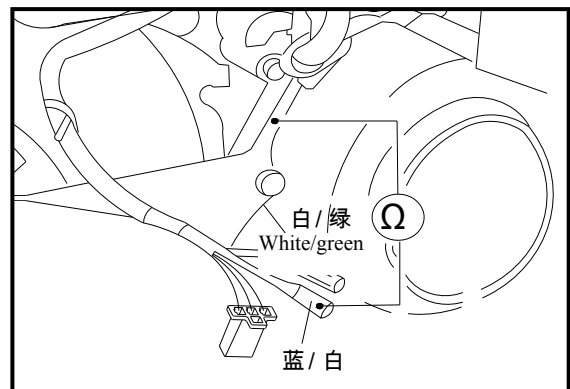

Blue/White

## 2.4 CDI group

### 2.4.1 System inspection

System inspection.

Disassemble the CDI group and inspect the parts related with the ignition system at the wire terminal.

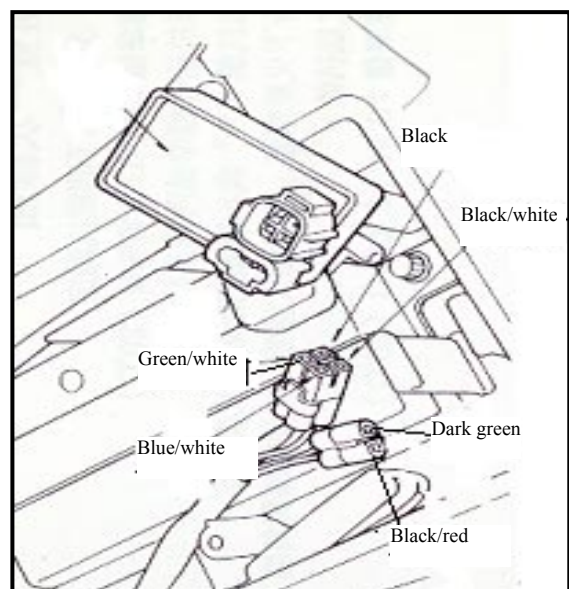

## 2.4.2 Inspection

Disassemble the CDI group and inspect whether the joint is loosen or eroded.

Inspection item	Testing terminal	Standard value ( 20℃ )
Main switch	red—red/white	Conducted when main switch at " OFF "
Trigger	Blue/white—white green	100-500Ω
primary ignition coil	black/white—black	0.6Ω±10%
Secondary ignition coil	black—spark plug cover ( spark plug not included )	0.5-5.5KΩ

## 2.5 Ignition coil

### 2.5.1 Disassembly

Disassemble the body guard.  
Disassemble the spark plug cover.  
Disassemble the primary ignition coil.  
Disassemble the ignition coil fixing bolts and unload the ignition coil.  
Installation is conducted in the reverse order of disassembly.

#### \*Attention

The primary coil is installed in accordance with the black/white wire.

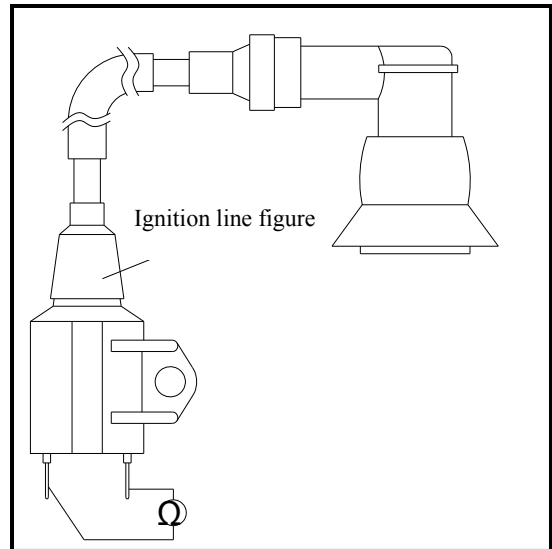

### 2.5.2 Inspect the primary coil

Measure the resistance between terminals of primary coil.

**Standard value :  $0.6\Omega \pm 10\%$  ( 20°C )**

If the resistance value is within standard value range, the primary coil is good.

The resistance value " $\infty$ " stands for broken line in the coil , so replace with a new product.

### 2.5.3 Secondary coil

Measure the resistance value between the wire of spark plug cover (with the spark plug) and the terminal.

**Standard value :  $5-11K\Omega$  ( 20°C )**

If the resistance value is within standard value range, the primary coil is good.

The resistance value " $\infty$ " stands for broken line in the coil.

Remove the spark plug cover and measure the resistance value between the primary wire of ignition coil and the negative terminal.

**Standard value :  $0.5-5.5K\Omega \pm 10\%$  ( 20°C )**

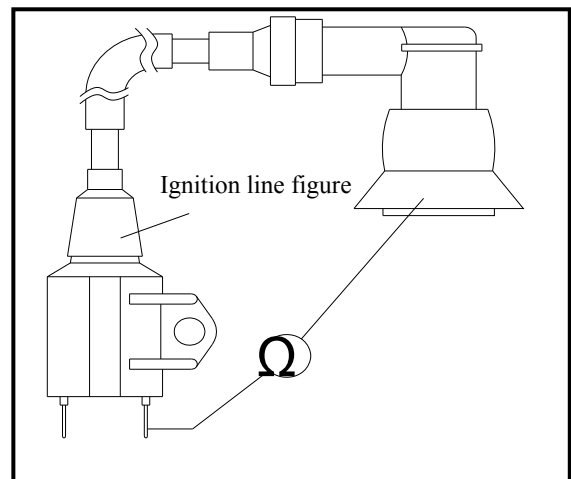

## 2.6 Trigger

#### \*Attention

Inspection of the trigger can be conducted on the engine.

#### Inspection

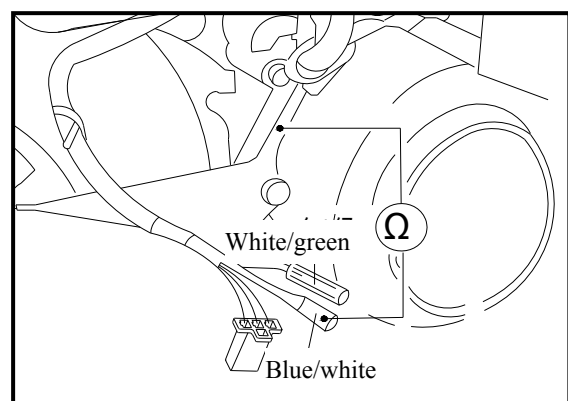

Disassemble the body guard.  
Disassemble the lead connector of the trigger.



Measure the resistance value between the blue/white terminal at the engine side and the body ground.

**Standard value : 100-500Ω ( 20°C )**

If the measured value exceeds the standard value, replace the alternator.

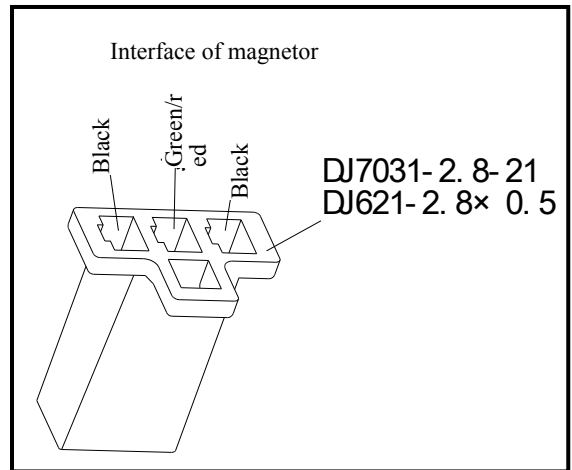

# Startup system

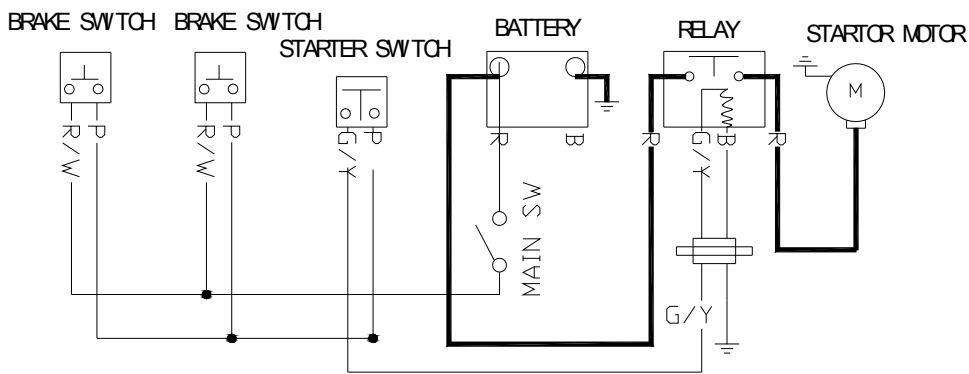
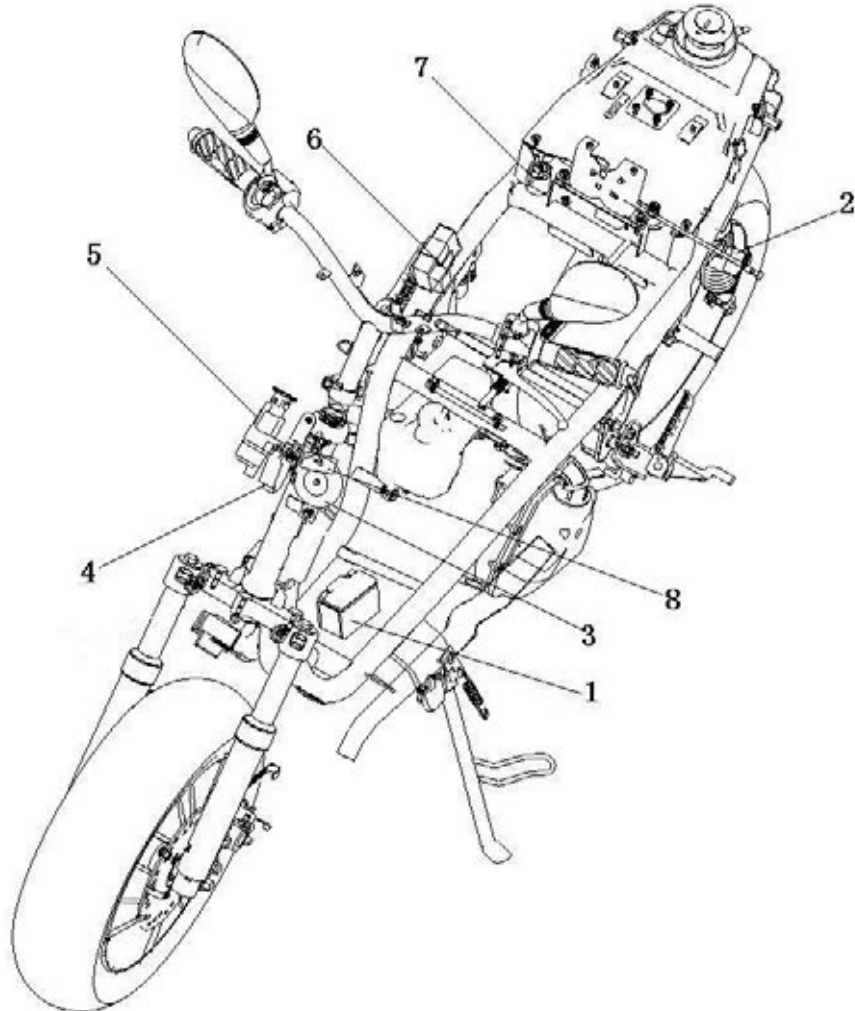

**Startup diagram**

1. Battery 12V, 4AH
2. Cushion lock module
3. Horn
4. Rectifier
5. Power lock module
6. Igniter
7. Relay
8. Release resistor

### III. Startup system

Preparation data -----3.1

Fault diagnosis -----3.2

Start electrical machinery -----3.3

Start relay -----3.4

#### 3.1 Preparation data

##### Matters needing attention in operation

Disassembly of the start electrical machinery may be conducted on the engine.

Please refer to disassembly operation in disassembly.

##### Preparation reference

Item	Standard value	Allowable limit
Brush length of startup motor	6.2mm	3mm
Liner of startup idler shaft		8.3mm
Outer diameter of startup idler shaft		7.94mm

##### Torque value

**Bolt in the clutch cover of the startup electrical machinery** 12 N·m

**Fixing nut in the clutch of the startup electrical machinery** 95 N·m

##### Tools

Fixing nut spanner

Multiple-use fixing spanner



### 3.2 Fault diagnosis

#### Unable to startup

- Fuse blown
- Power shortage in battery
- Bad acts of main switch
- Bad act of startup clutch
- Bad act of brake switch
- Bad act of start relay
- Poor contact of connecting wire
- Bad act of startup electrical machinery

#### Rotating force of start machinery too weak

- Power shortage in battery
- Poor contact of connecting wire
- Gear of the startup machinery jammed with foreign body

#### No revolution in the RE Rotary Engine

- Bad act of startup clutch
- Reverse revolution of startup electrical machinery
- Power shortage in battery

### 3.3 Start electric machinery

#### 3.3.1 Disassembly

##### \*Attention

The main switch must be switched to "OFF" before disassembly of the startup electrical machinery. Dismantle the bonding strip of the battery and turn on the power supply to see whether the startup electrical machinery will run so as to confirm security.

First take down the wire clamp of the startup electrical machinery dismantle the fixed bolt of starting motor.

Separate the front end cover and the rear one. Remove the starting motor.

Roll up the rubber waterproof jacket and disassemble the joint of startup electrical machinery.

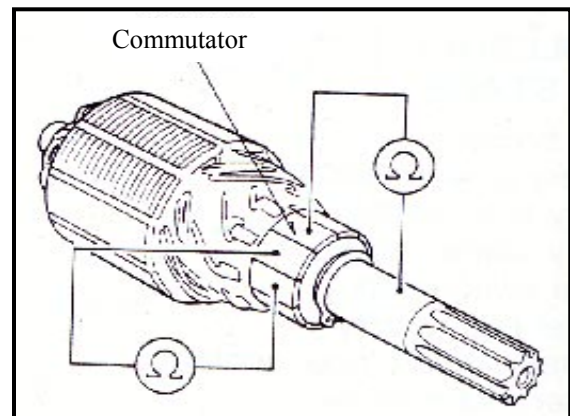

#### 3.3.2 Dismantling

Disassemble the housing bolts, front cover, motor housing and others.

#### 3.3.3 Inspection

Inspect other spare parts.

If uneven wear, damage or burning is detected on the surface, replace it with a new one.

The adhesive metal powder between commuator surfaces

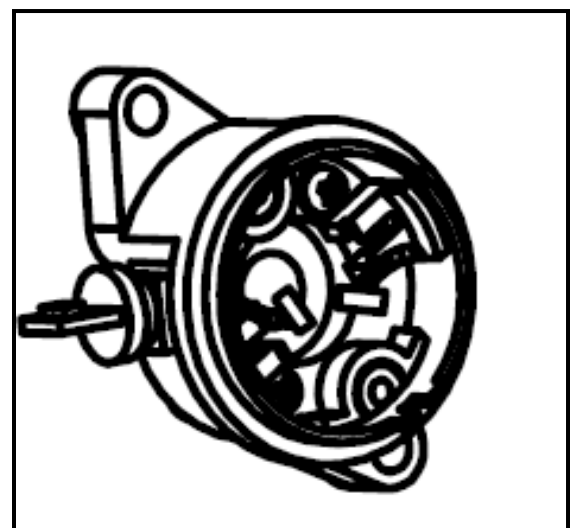

must be cleaned away.

Inspect conduction of contact surfaces between other assemblies.

Confirm the armature shafts between each surface of the commutator cannot be connected.

Inspect conduction of the housing of startup.

Confirm the terminal and housing of the startup electric machinery cannot be connected.

Inspect conduction of the terminal and electric brush.

If there is disorder, replace is with a new one.

Inspect conduction of the brush holder. If there is conduction, replace is with a new one.

Measure the length of the electric brush.

**Allowable limit : 3mm(under the value, replace it)**

Inspect whether the needle shaft in the front cover is flexible in rotation and whether it is loosen when pressed in.

If there is disorder, replace is with a new one.

Inspect whether the oil seal is worn out or damaged.

### 3.3.4 Assembly

Oil seal in the front cover and coating of grease.

Mount the electric brush on the brush holder.

Spread grease on the active parts of the electric brush ends.

Press all brushes in bracket and then install front cover of electrode.

#### \*Attention

- Take particular care that the contact surface of the electric brush and armature can not be damaged.
- Take care in case the mounting shaft of the armature should damage the oil seal lip.

Put a new O-ring on front cover.

Install with the boss on motor casing engaging with the recess on front cover.

Screw the housing bolts.

#### \*Attention

When the housing and front cover is assembled together, the armature is easy to pull up with a magnet attracting the front cover and can be put together with slight press down by hand.

### 3.3.5 Installation

Mount the wire of the startup electrical machinery and

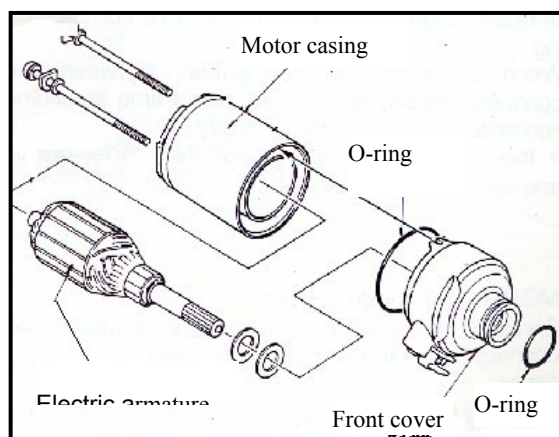

confirm the soldering cup is installed.

Check the O-ring for damage. If abnormal situation is found, replace it with a new one.

Apply engine oil to the O-ring and then fit it on the starting motor.

Install the wire clamp of the rear brake.



## 3.4 Start relay

### 3.4.1 Actuation inspection

Disassemble the body guard.

Push the main switch to "ON" and press the startup electrical machinery with a "click".

Sound means normal.

No sound : •Inspect voltage of the start relay

- Inspect the earth line of the start relay.
- Inspect actuation of the start relay

### 3.4.2 Inspect voltage of the start relay

Erect the main stand and measure the voltage between the earth line of the frame and the negative polar of the green/yellow line of the starting relay connector.

Push the main switch to "ON" to pick up the brake rod. The battery voltage should conform to regulations.

If there is no voltage on the starting relay line, inspect the wire and conduction of the brake switch.

### 3.4.3 Inspect the earth line of the start relay

Remove the connector of start relay.

Inspect conduction between the gray line at the lead connector terminal and the body ground.

When pressing the start button, the gray line of the connector and the body ground are in good conduction.

If no conduction occurs, inspect the wire and conduction performance of the start button.

### 3.4.4 Actuation inspection

Connect the starting relay with the battery and connect the terminal of startup electric machinery with the avometer.

Connect the fully charged battery between the black line and green/ yellow line of the relay. At this point, the relay should give out a "Click" sound and the avometer resistance

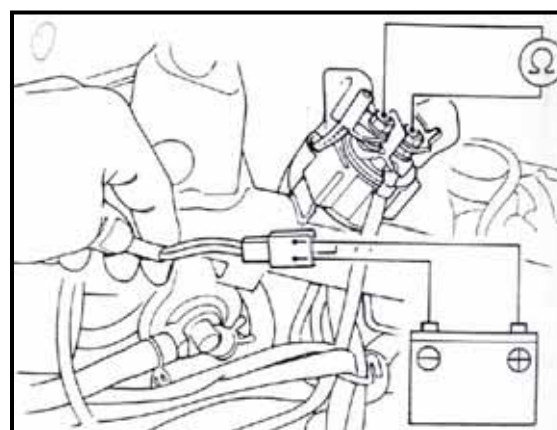
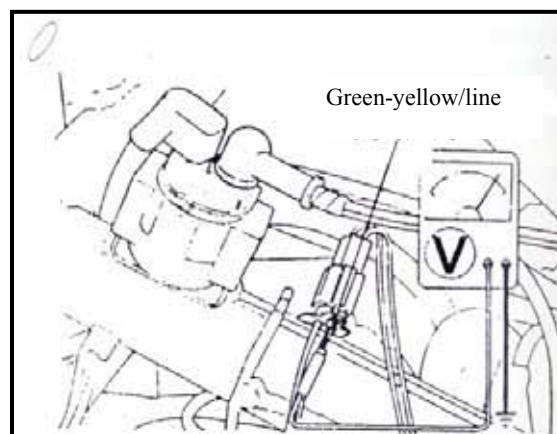
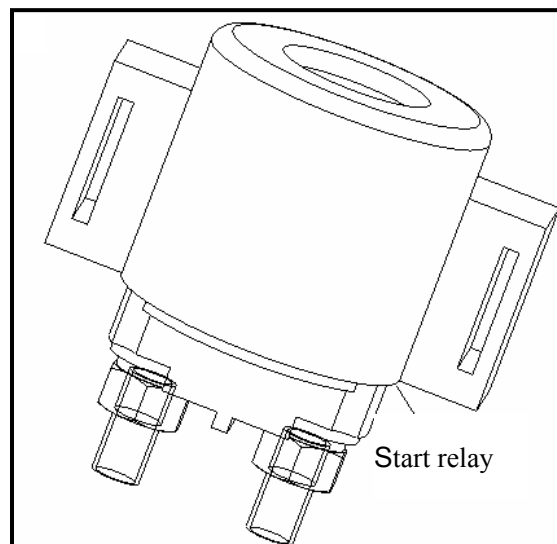

reads "0".

## Bulbs/ switch/instrument

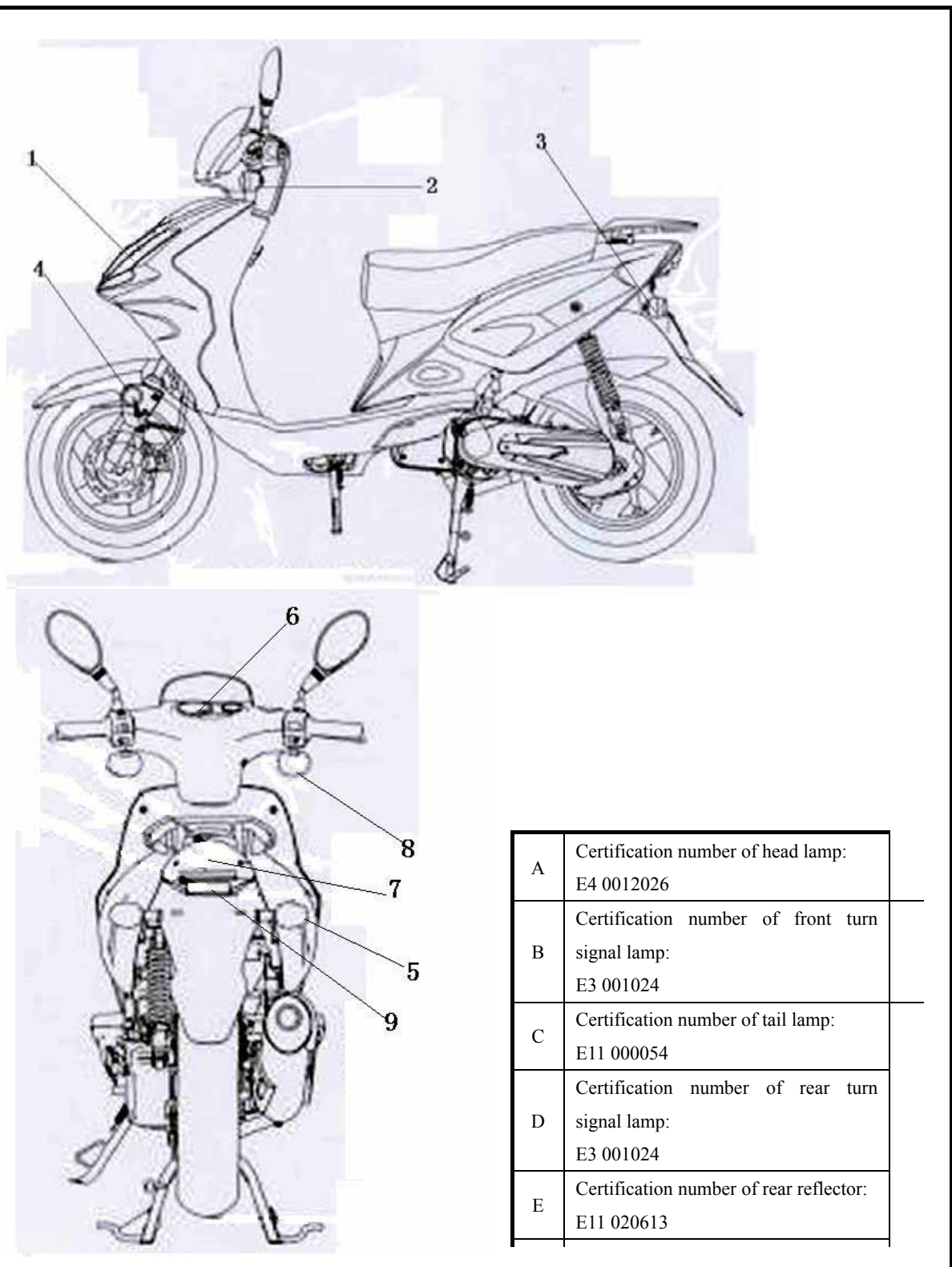

1. Head lamp    2. Turn signal lamp (FL)    3. Turn signal lamp (RL)    4. Side reflector    5. Turn signal lamp (RR)    6. Meter    7. Tail lamp    8. Turn signal lamp (FR)    9. Rear reflector

## IV. Bulbs/ switch/instrument

Preparation data -----4.1	Instrument-----4.6
Fault diagnosis -----4.2	Main switch -----4.7
Replace the head light bulb -----4.3	Horn-----4.8
Replace bulb of the front turning light----4.4	Handle switch -----4.9
Replace the bulb of the taillight -----4.5	

### 4.1 Preparation data

#### Matters needing attention in operation

The conduction of switches may be measured after disassembled from the motorcycle.

### 4.2 Fault diagnosis

Main switch is pushed to "ON" but the light doesn't work.

- Bad act of the bulb
- Bad act of the switch
- Poor contact of the connector or broken line

### 4.3 Replace the head light bulb

#### 4.3.1 Disassembly

Dismantle the front cover.

Disassemble the fixing bolts so that the head light could be disassembled.

Cut off the switch connecter of the head lamp.

Remove the head lamp.

Disassemble the air guide sleeve.

Disassemble the glass sheet on the head light.

Fix the head light and turn the socket clockwise so that the bulb can be removed.

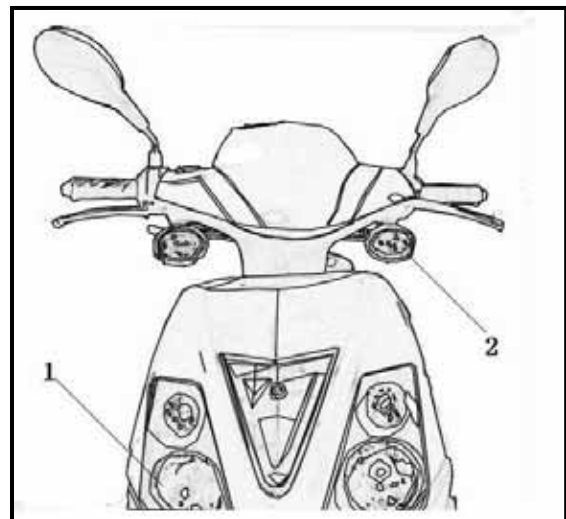

#### 4.3.2 Installation

Install the bulb back to the original position in the reverse order of disassembly.

## 4.4 Replace bulb of the front turning light

### 4.4.1 Disassembly

Remove front shield of handle pipe.  
Disconnect connecting wire of front turn signal lamp.  
Unscrew the setscrew on the turning light.  
Remove the bulb socket from the light.

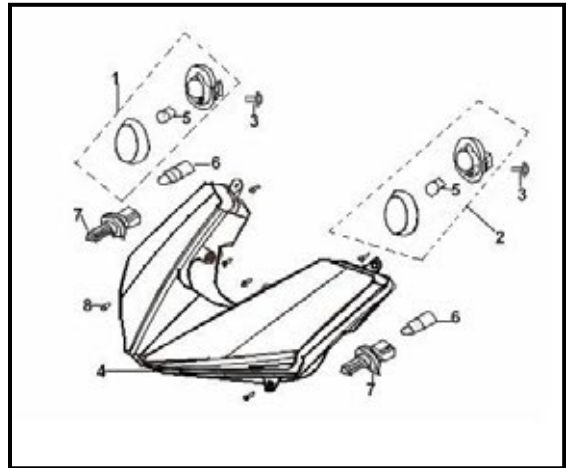

### 4.4.2 Installation

Install the bulb back to the original position in the reverse order of disassembly.

## 4.5 Disassembly/replace the bulb of the taillight and rear-right turning light

### 4.5.1 Disassembly

Remove seat cushion.  
Remove set screws of left and right rear fenders so that tail lamp shade can be taken off.  
Disconnect wire connectors of tail lamp and left and right turn signal lamps.  
Remove left and right rear fenders (1), tail lamp shade and rear license bracket. Remove tail lamp (4).  
Remove tail lamp (4) and rear left and right turn signal lamps.

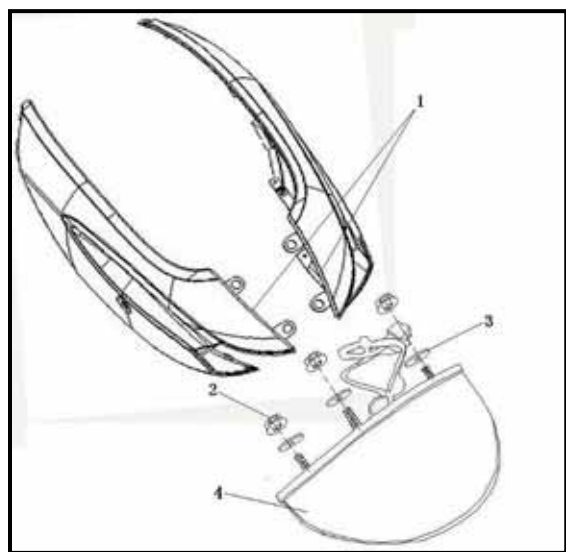

### 4.5.2 Installation

Install the taillight back to the original position in the reverse order of disassembly.

### 4.5.3 Replace the bulb of the taillight

#### 4.5.3.1 Disassembly

Remove set screws of tail lamp shade.  
Remove tail lamp shade together with tail lamp bulb.  
Remove bulbs (left and right turn signal lamp bulbs and tail lamp bulb) from bulb holders.

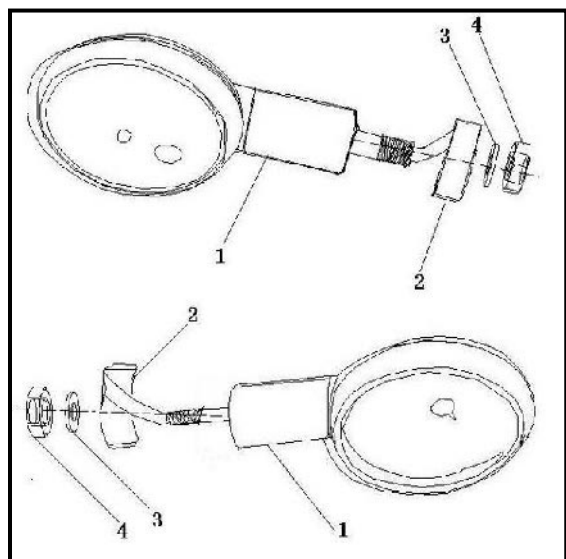

### 4.5.3.2 Installation

Install the bulb back to the original position in the reverse take turns of disassembly. Install the bulb back to the original position in the reverse take turns of disassembly.

## 4.6 Instrument

Remove set screws of front shield of handle pipe.

Remove set screws of instrument.

Disconnect odometer wire connector to remove the instrument..

Install the speed indicator back to the original position in the reverse order of disassembly.

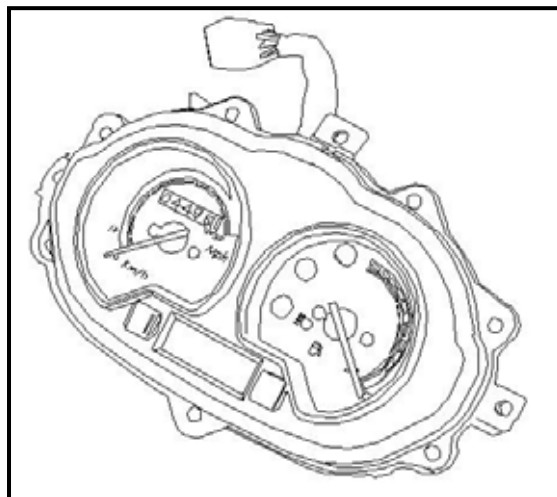

## 4.7 Main switch

### 4.7.1 Inspection

Remove front cover twin-lamp panel.

Remove foot protection plate.

Dismantle the wire joint of the main switch.

The conduction checking of the joint terminal.

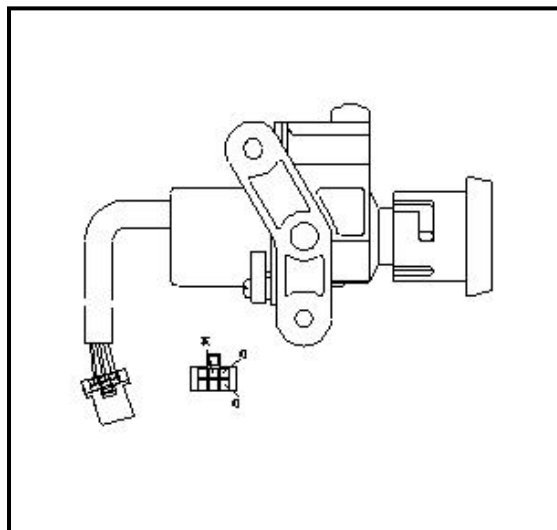

**Wiring logic diagram**

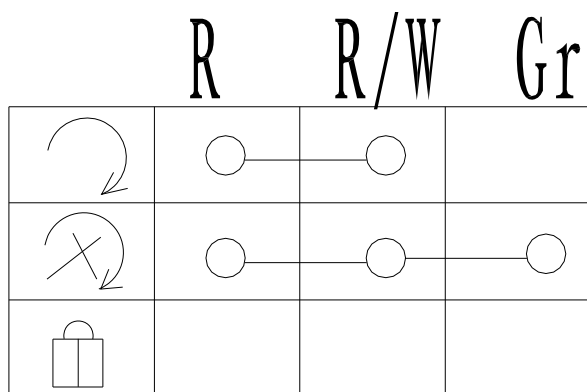

### 4.7.2 Replacement of main switch

Remove front cover twin-lamp panel.

Remove foot protection plate.

Disassemble the setscrews, unload the fixing pad of the main switch.

Disassemble the setscrews and replace the main switch.

## 4.8 Horn

### Inspection

Disassemble the horn wire.

If the horn rings when the horn wire is connected with the battery, then it is the fine conditions.

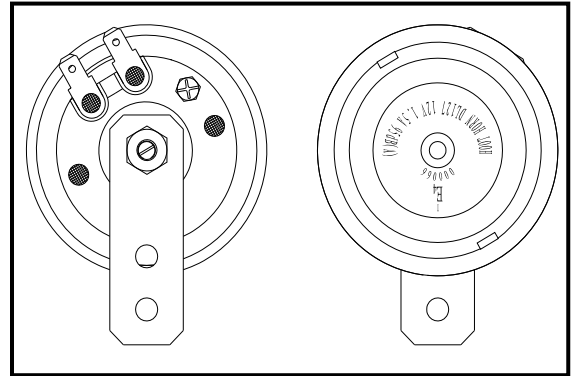

## 4.9 Handle switch

Remove left and right rear-view mirrors.

Remove set screws of left and right combination switches.

Loosen left and right combination switches.

Remove right grip module and left steering handle sheath.

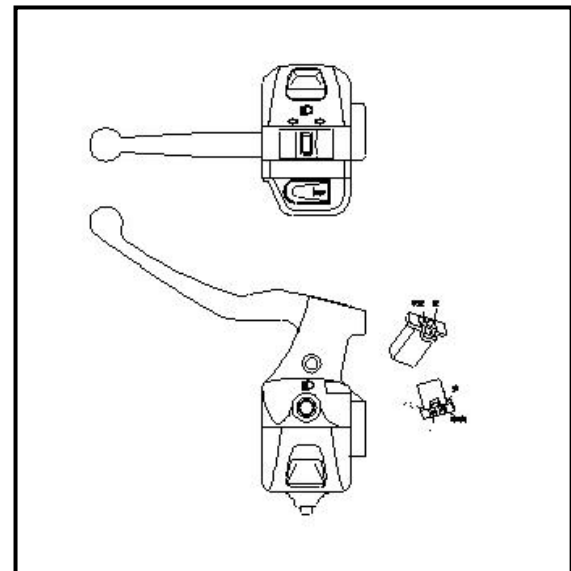

Take off left and right combination switches.

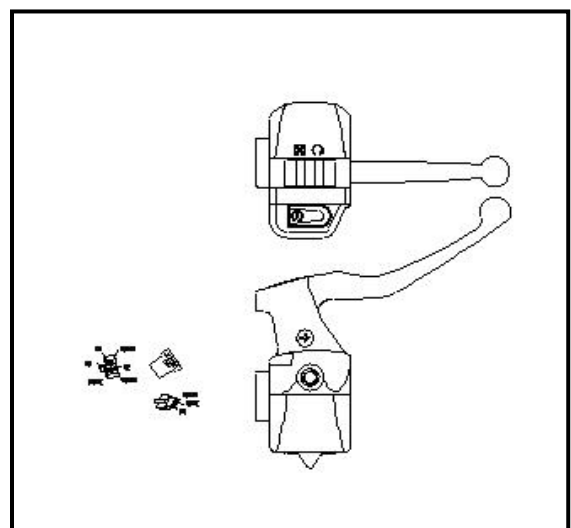





## Inspection and Service of Chassis

**Table of Torques for Fasteners on Chassis**

Fastening location and name of fastener	Tightening torque (N·m)
Fixing bolt of oil pump body module	5-9
Mounting bolt of front brake cylinder module	22-29
Fixing bolt of rear brake rocker arm	5-9
Fixing nut of rear wheel	100-113
Fixing bolt of welded module of steering handle	40-60
Lock nut of front wheel spindle	55-62
Front wheel spindle	55-62
Fixing nut of rear wheel	100-113
Top nut of rear shock absorber	37-44
Bottom nut of rear shock absorber	22-29
Fixing bolt of rear shelf support	5-9
Fixing bolt of fuel tank	5-9
Fixing bolt of helmet bucket	5-9
Fixing bolt of muffler	22-29
Fixing bolt of muffler joint	5-9

# Front liquid brake

A	Diameter of front brake disc: 190mm
B	Thickness of front brake disc: 4.0mm Service limit: 3.0mm
C	Thickness of friction lining: 6.0mm Service limit: 5.0mm
D	Mounting torque value of the bolt (9) shown in the figure: 5-9N·m
E	Mounting torque value of the nut (29) shown in the figure: 37-44N·m
F	Free stroke of brake lever: 10-20mm

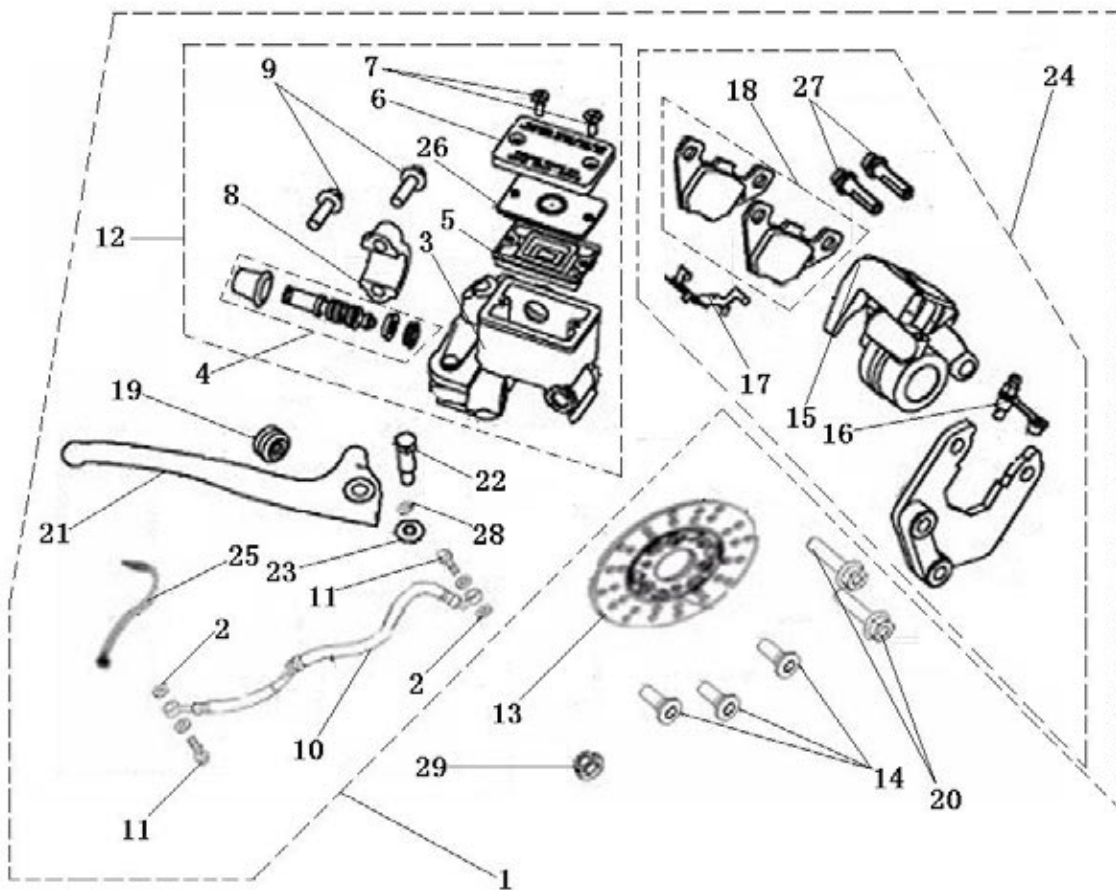

1. Hydraulic brake assembly    2. Gasket    3. Oil pump body    4. Plunger module    5. Oil cup pad    6. Oil cup cover    7. Screw M4×10    8. Fixing cover of handle seat    9. Screw M6×23    10. Brake hose assembly  
 11. Coupling bolt    12. Oil pump body module    13. Front brake disc    14. Mounting bolt of front brake disc  
 15. Brake cylinder    16. Dust cover of bleeder valve    17. Spring leaf    18. Friction lining module    19. Return spring of handle    20. Bolt    21. Hydraulic brake lever    22. Bolt    23. Nut M6    24. Brake cylinder

module 25. Front brake switch nut of front brake disc M10×1.25 26. Oil pump body gasket 27. Small pillar 28. Washer 29. Mounting

## Rear brake drum

A	Mounting torque value of the nut (11) shown in the figure: 100-113N·m
B	Bore of brake drum: 110mm Wear limit: 111mm
C	Thickness of brake shoe: 6.0mm Service limit: 5.0mm
D	Free stroke of rear brake lever: 10-20mm

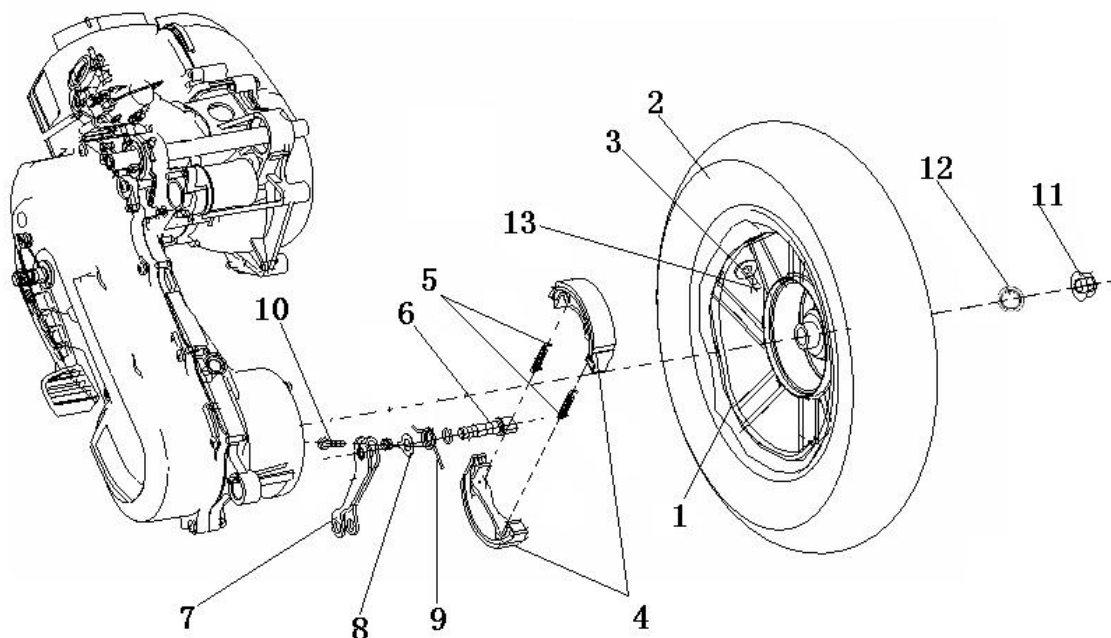

1. Rear rim
2. Tire 130/70-12
3. Tire valve
4. Brake shoe module
5. Brake shoe tension spring
6. Rear brake camshaft
7. Rear brake rocker arm module
8. Rear indicator
9. Return spring of rear brake
10. Rear rocker arm bolt
11. Nut
12. Scraper seal
13. Tire valve cap

## V. Brake

Maintenance instruction -----5.1  
 Fault diagnosis -----5.2  
 Front liquid brake-----5.3  
 Rear brake drum -----5.4

### 5.1 Maintenance instruction

#### Matters needing attention in operation

##### \*Attention

- The braking components can not be spoiled by oil stain in installation or disassembly.
- Rinse with stipulated cleaning agent in order to avoid reduction of braking quality.

\* Inspect the brake before riding the motorcycle.\*

#### 5.1.1 Specification

Item	Standard value (mm)	Allowable limit(mm)
thickness of front brake disc	4.0	3.0
Thickness of front friction lining	6.0	5.0
Diameter of front brake disc	190	-
Bore of rear brake drum	110	111
thickness of rear brake pad	6.0	5.0

#### 5.1.2 Torque value

Fixing bolt of oil pump components

5-9 N·m

Assemble bolt for the front brake cylinder components 22-29 N·m

Fixing bolt of rear brake rocker arm 5-9 N·m

Fixing bolt of rear brake rocker arm 100-113 N·m

## 5.2 Fault diagnosis

### Brake

#### Bad braking quality

1. Unfavorable brake adjustment
2. Brake shoe and friction lining module worn
3. Brake shoe and friction lining module installed improperly
4. Brake shoe, friction lining module and brake disc contaminated

#### Slow brake or handle tightening

1. Unfavorable brake adjustment
2. Brake shoe and friction lining module worn
3. Brake shoe and friction lining module installed improperly

#### Strange sound in braking

1. Brake shoe and friction lining module worn
2. Brake shoe, friction lining module and brake disc contaminated

## 5.3 Front hydraulic brake

### 5.3.1 Disassembly

#### \*Attention

- Friction lining module replacement.

•If a brake pad is reused, mark a signal on its side before disassembly so that it can be installed to the original position.

Remove the following modules from right grip and front shock absorber respectively:

#### Front brake:

1. Hydraulic brake lever (21)
2. Oil pump body module (3)
3. Brake hose assembly (10)
4. Brake cylinder module (15)
5. Brake disc (13)

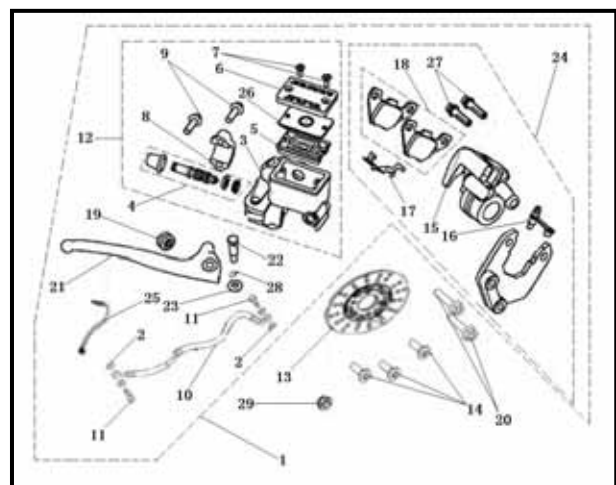

**Note: Detailed decomposition map can be seen on P78**

**\*Attention**

- The braking components can not be spoiled by oil stain in installation or disassembly.
- Rinse with stipulated cleaning agent in order to avoid reduction of braking quality.

Unclamp the fixed bolt of the brake cylinder components.  
Antle the following components from the front absorber.  
Disassemble the front wheel spindle.  
Unload the front wheel.  
Remove the brake disk from the front wheel.

**5.3.2 Inspection**

Inspect whether the brake pad is worn out and replace it if necessary.  
Measure the brake pad and brake disc and put down the maximal value.

**Specification**

**RACE 50 diameter of front hydraulic brake  $\phi$ 190mm**

**diameter of front hydraulic brake 4.0mm**

**\*Attention**

- It must be measured with microcaliper.

Measure the thickness of brake pad.  
If thicknesses of brake disc and friction lining module are less than the service values or they are contaminated by grease, replace.

**Allowable limit: brake pad 5.0mm**

**brake disc 3.0mm**

**Note:**

**the brake clutch should be replaced in pairs.**

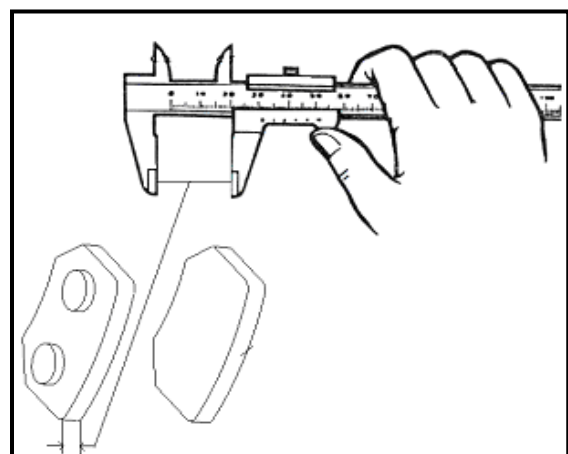
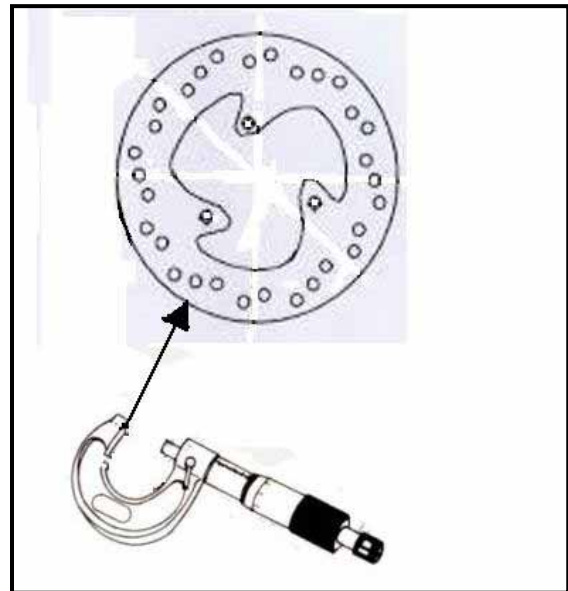

**5.3.3 Installation**

Install the brake disk and front wheel.

Install the brake hose assembly of the front brake, and the brake cylinder components ( 2 ) .

Prevent brake clutch ( 3 ) and brake disk from greasing.

**\*Attention**

Presence of grease on friction lining will reduce braking performance resulting in brake failure.

Screw bolt and nut to the stipulated torque force value.

**Torque value :**

**Fixing bolt of oil pump body module                    5-9 N·m**

**Mounting bolt of front brake cylinder module            22-29 N·m**

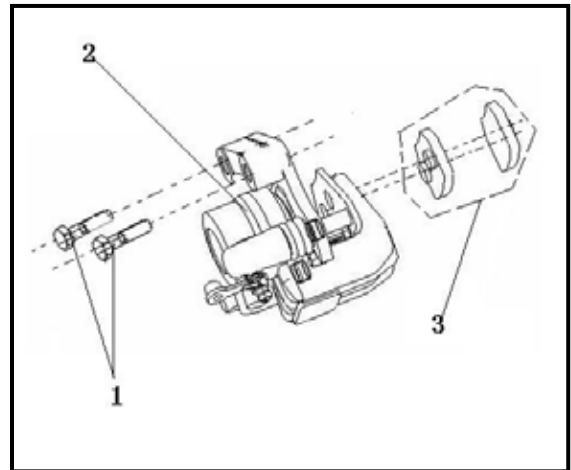

Do not allow oil stains to stick to friction lining.  
If oil stains stick to friction lining, clean with brake washing fluid.

**\*Attention**

Oil stains sticking to friction lining will reduce braking performance.

**5.4 Rear drum brake**

**5.4.1 Disassembly**

- Remove muffler.
- Remove fixing nut of rear wheel (11).
- Remove rear wheel.
- Remove brake shoe module (4).

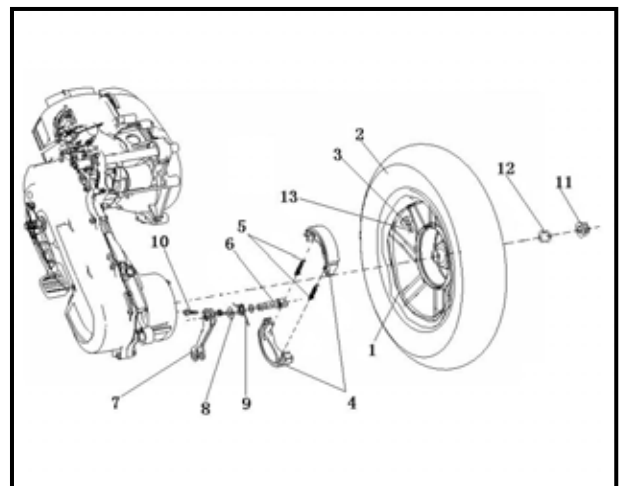

**\*Attention**

- Always replace the brake pad in pairs.
- If a brake pad is reused, mark a signal on its side before

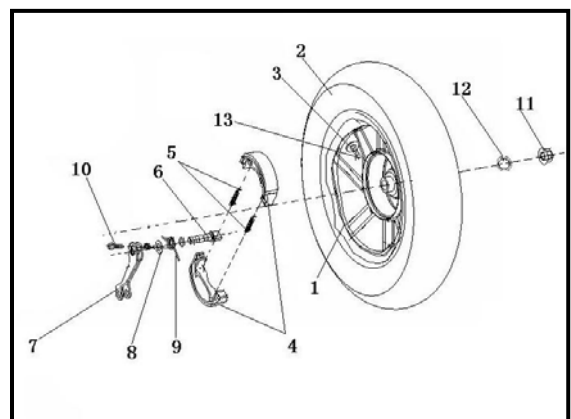

disassembly so that it can be installed to the original position.  
Remove the following components from the rear wheel.

Rear brake:

1. Bolt
2. Rear brake rocker arm module (7)
3. Nut
4. Rear indicator (8)
5. Rear brake return spring (9)
6. Rear brake camshaft (6)
7. Brake shoe module (4)
8. Brake shoe tension spring (5)
9. Outer cover 130/70-12 (2)
10. Rear rim (1)
11. Fixing nut of rear wheel (11)
12. Scraper seal (12)

**Note:** Detailed decomposition map can be seen on P79.

### 5.4.2 Inspection

Check brake drum and brake shoe for wear. When needed, replace.

Measure thickness of brake shoe and bore of brake drum and take down the maximum values.

**\*Attention**

- Be sure to use a micrometer to measure
- Measure bore of brake drum and thickness of brake shoe.

If the thickness of brake pad is less than the maintenance value or it is polluted by grease, just replace it.

**Note:** the brake clutch should be replaced in pairs.

**Bore of rear brake drum**                      **φ110mm**

**Thickness of rear brake shoe**              **6.0mm**

**Allowable limit: Bore of brake drum**   **φ111mm**

**Brake shoe**                                      **5.0mm**

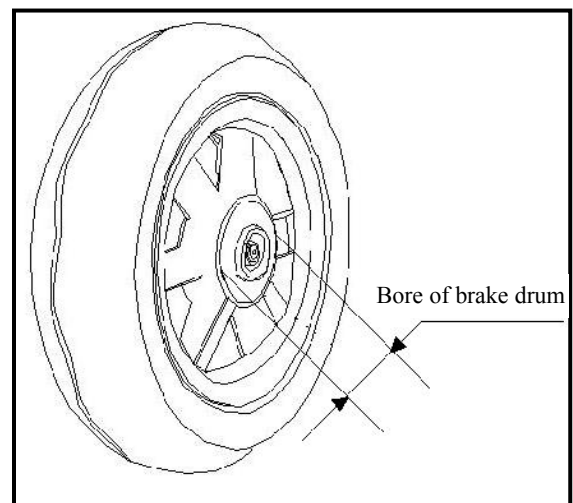
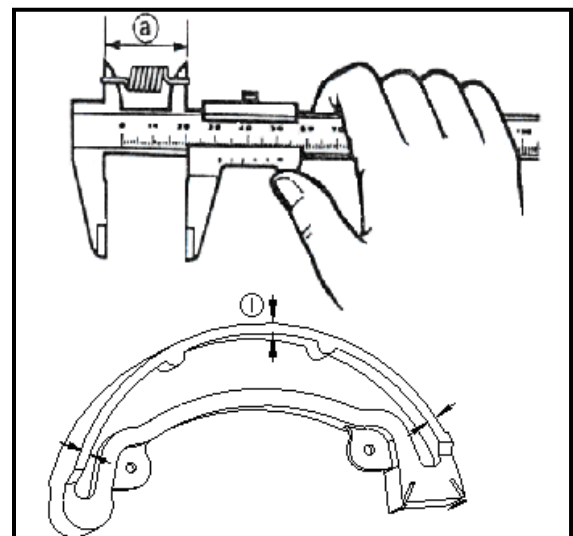

### 5.4.3 Installation

- Install brake shoe module.
- Install rear wheel.
- Reinstall muffler.



**\*Attention**

Grease on the brake pad may reduce brake ability and invalidate the brake.

Screw the bolt and nut to the stipulated torque force value.

**Torque value :**

**Fixing nut of rear wheel: 100-113N·m**

Keep the brake pad and brake disc free of oil stain.  
If the brake pad and brake disc are polluted with oil,  
rinse them with brake cleaning fluid.

**Rear brake:**

- |                                     |                                   |
|-------------------------------------|-----------------------------------|
| 1. Bolt                             | 7. Brake shoe module (4)          |
| 2. Rear brake rocker arm module (7) | 8. Brake shoe tension spring (5)  |
| 3. Nut                              | 9. Outer cover 130/70-12 (2)      |
| 4. Rear indicator (8)               | 10. Rear rim (1)                  |
| 5. Rear brake return spring (9)     | 11. Fixing nut of rear wheel (11) |
| 6. Rear brake camshaft (6)          |                                   |

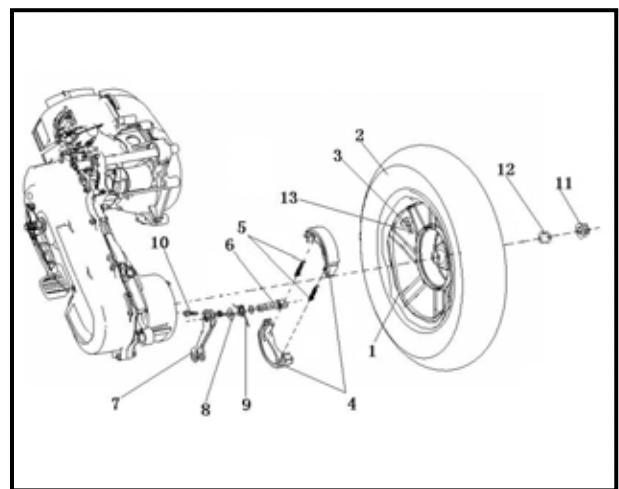

**\*Attention**

Oil stain on the brake clutch will reduce its performance.

Note: Detailed decomposition map can be seen on P79.

# Body cover

**\*Attention**

The cover of car body must not be damaged when taken apart.

The hook claws of the body cover must not be damaged when taken apart.

Correspond the embedded panel and spear plate of car body with respective slot.

In the composition, hook in each part must be installed correctly.

Accessories should not be damaged in the installation of cover parts.

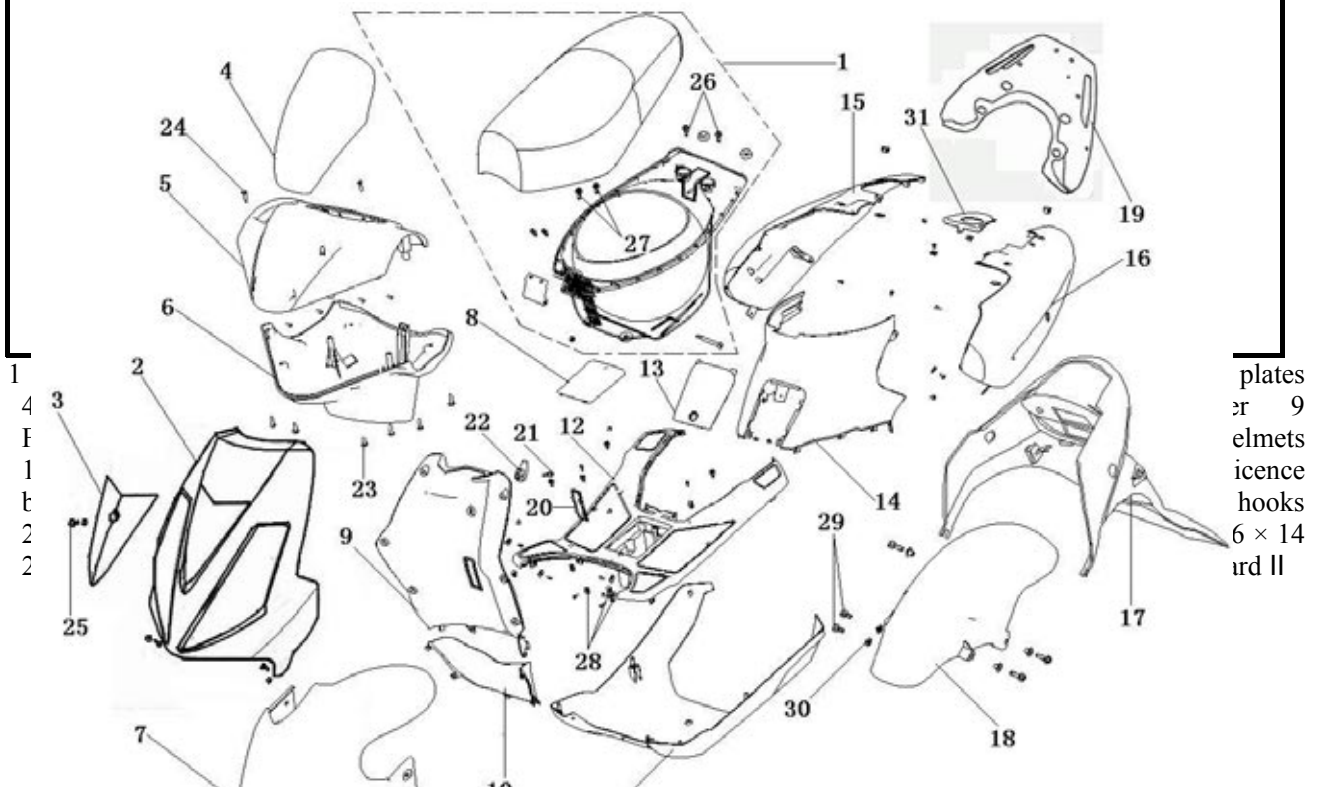

## VI. Body cover

Disassemble the motorcycle body according to the following order:

Cushion covers components → front big cover panel components → front shielding → back shielding  
→ front mudguards →



Back shelf → helmet box front cover → boards linking plate I → boards linking plate II → left /  
right protection components



Back licence brackets → back mudguards → battery lid → foot panel → lower lid → inside  
mudguards



→ helmet hooks → foot guard board component

### **\*Attention**

Do not damage any body cover during installation or disassembly.

Do not damage the knuckle on body cover during installation or disassembly.

Align the panel and cover plate on the body cover with their own grooves.

Correctly install the knuckle of each part in assembly.

No spare parts could be damaged in installation of the cover.

## **Front wheel**

A	Tire specifications: outer tire 120/70-12
B	Wheels specifications: 3.50 × 12
C	Rims facing poor limits: vertical: 2.0 mm horizontal: 2.0 mm
D	Front wheel axle degree limits: 0.2 mm
E	Outer tire of front wheel certification of: E11 75R

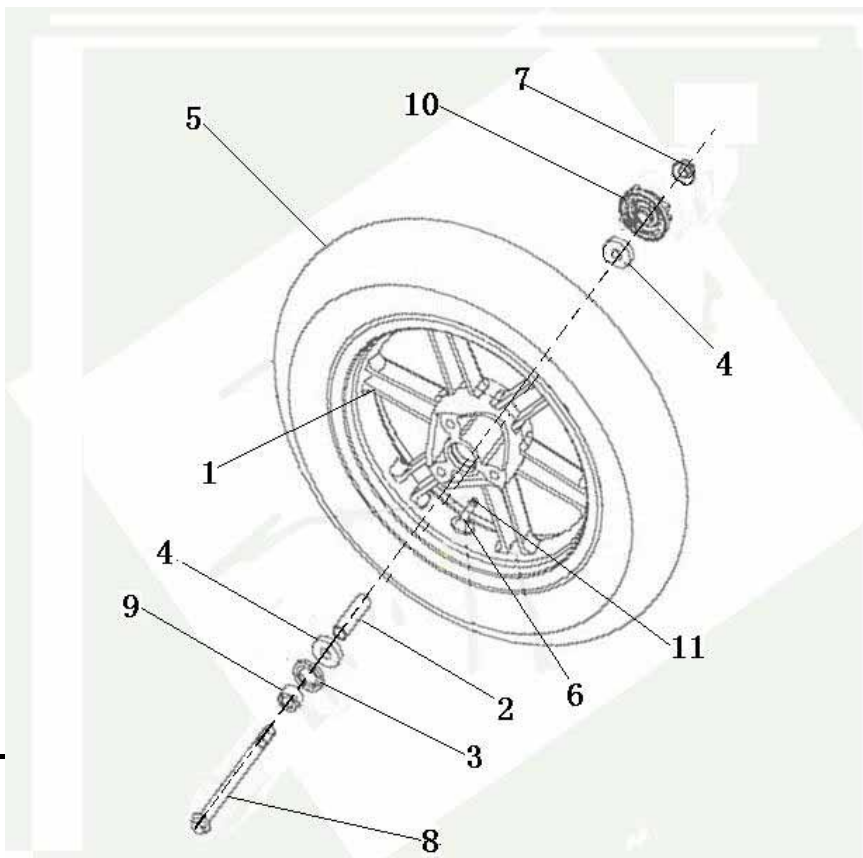

1 Front wheel  
120/70-12

10 gear wheel bracket component nuts    11 valve cap

101-2RS    5 tires  
left axis cover

# Front suspension

A	Installed torque value in the map of bolt 11: 5-9 N.m
B	Installed torque value in the map of bolt 14:40-60 N • m
C	The number of steel ball on the top: 21
	The number of steel ball on the bottom: 21

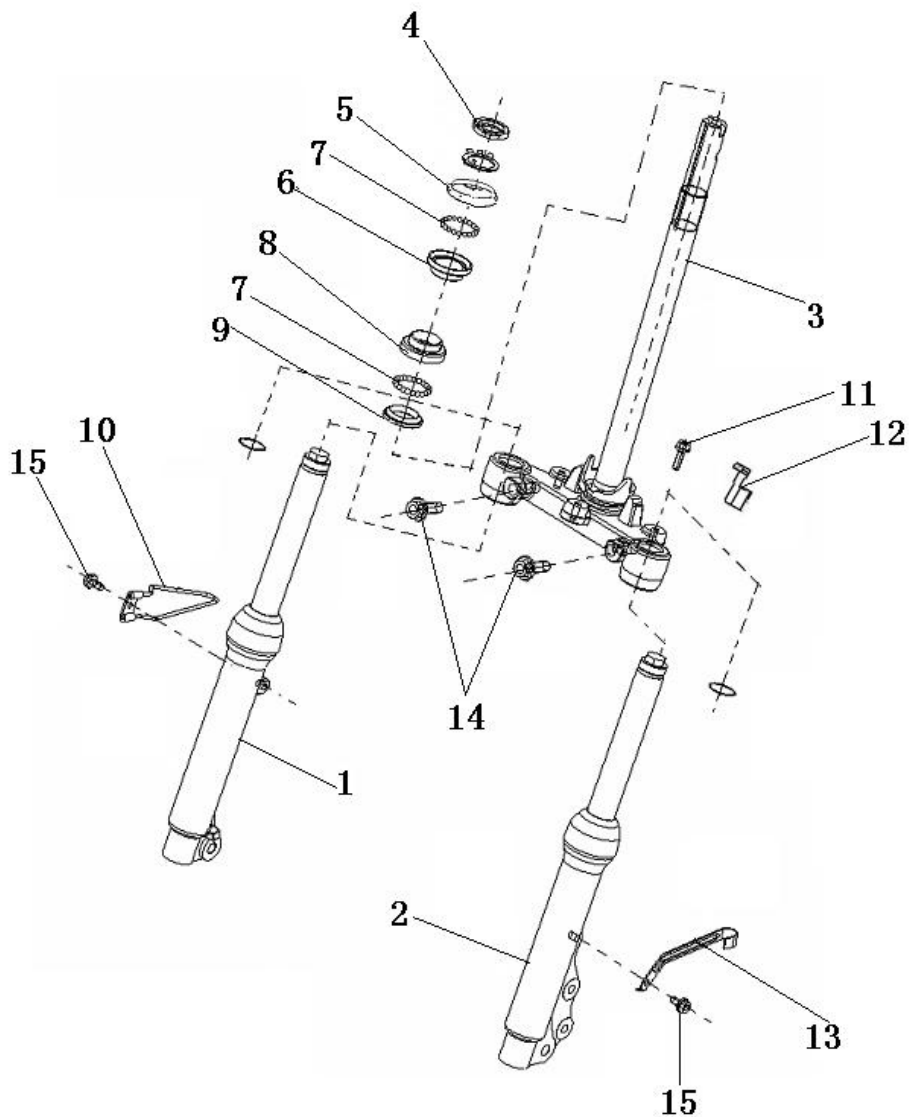

1 Front right components up steel bow

e plate seal  
wn bearings,  
× 12 12

cadres of brake fluid Clamps 2 13 cadres of brake fluid Clamps 1 14 bolts M10 × 1.25 × 30 15 bolts M6 × 16

## Manipulation assembly

A	Installation torque values of bolts 2 (direction knob fixes the bolts) in the map 2: 40-60 N • m
B	Free trip of front shake handle before the brake handle free trip :10-20 mm
C	Installation torque values of bolts 3 in the map: 40-60 N • m
D	Free trip of throttle manipulation :2-5 mm

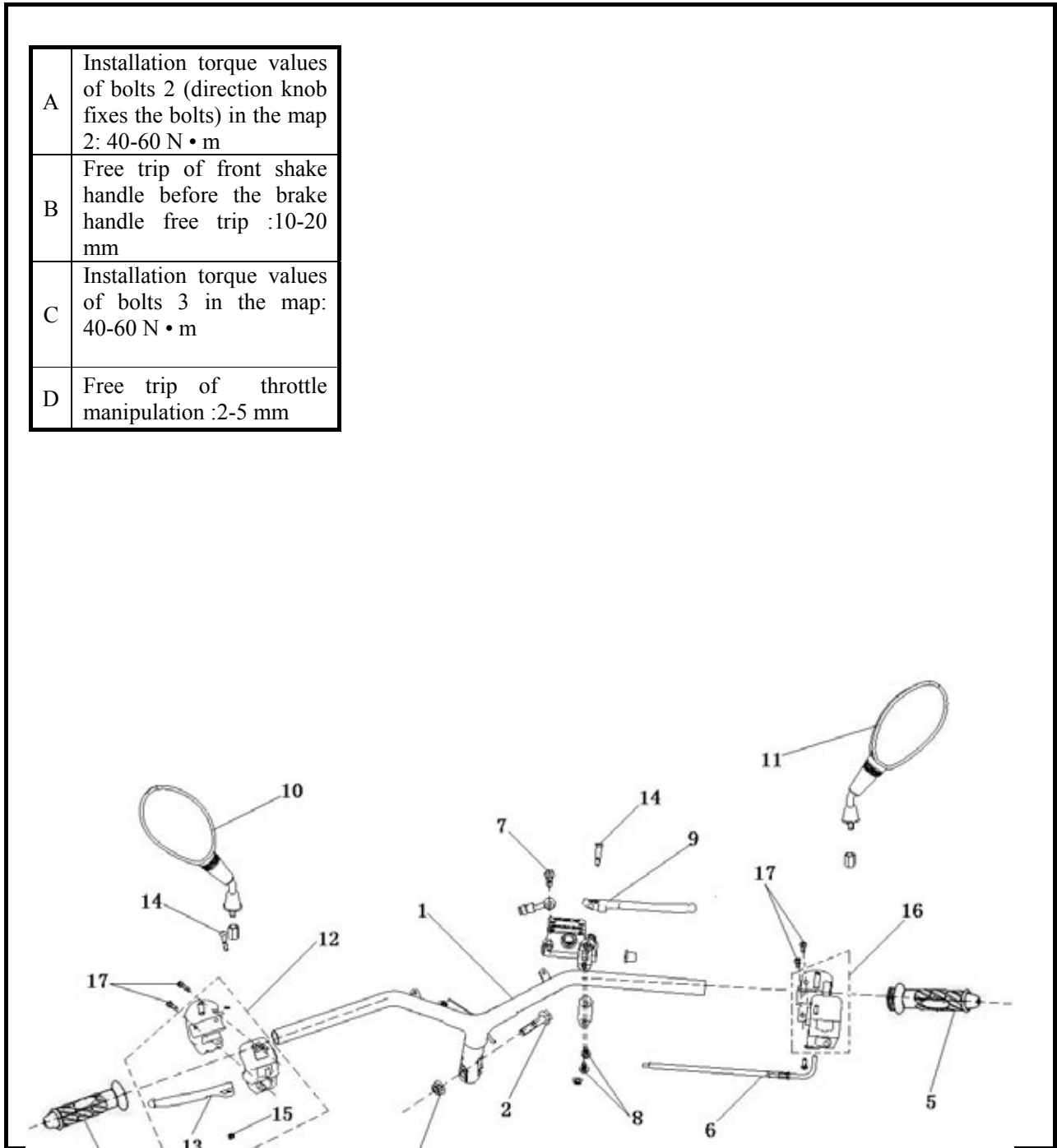

1  
6

handle  
10

left rear view mirror components 11 Right rear rearview mirror components 12 Left combination switch  
 13 left handle 14 Fixed handle screw M5 15 Nut M5 16-17 Right combination switch 17 Flat screw  
 M5 × 20

## VII. Front wheel/ front suspension

Preparation data -----7.1

Fault diagnosis -----7.2

Front wheel -----7.3

Direction handle-----7.4

Front fork -----7.5

### 7.1 Preparation data

#### Matters needing attention in operation

Before the demolition of the front wheels, the bottom of the body should be supported by jack, and the front-wheel-floating ground should not be attention to the ground can not be invertible.

During the operating, the brake shoes block, friction-chip components, brake disc can not be attached to oil.

#### Reference for the entire motorcycle

Measuring position	Item	standard value (mm)	Allowable limit(mm)
front wheel spindle	bending		0.2
front wheel	run-out of rim	vertical direction	2.0
		transverse direction	Within 1.0

#### Torque value

#### Tools

The direction knob seal component fix bolt 40-60 N·m

Bearing puller

Front axle lock nut 100-113 N·m

Lock-in nut wrench

Front axle 100-113 N·m

### 7.2 Fault diagnosis

#### 7.2.1 It's hard to rotate the direction handle

Malfunction of the direction handle bearing.



The direction handle bearing is damaged.

The air pressure of tire is ultra-low.

Air leakage of tire.

### 7.2.2 The direction is not stable.

The direction handle bearing is damaged.

The tire compression is not sufficient.

The front fork and the front wheel axle are crooked.

The tire of the front wheel is deformed, with crooked tire.

### 7.2.3 Front wheel yawing

The rim is distorted.

The front wheel bearing is loosened.

The tyre is not good.

### 7.2.4 The wheels rotate with difficulties.

The wheel-axle bearing or the gear seats are in failure.

### 7.2.5 Strange noise in front shock absorber

Friction noise in shock absorber guard

Loosening of bolts in shock absorber.

## 7.3 Front wheel

### 7.3.1 Disassembly

#### \*Attention

Must prop the motorcycle firmly before head.

Loose the mounting bolt ( 1 ) of components of the braking cylinder.

Remove components (2) of the braking cylinder.

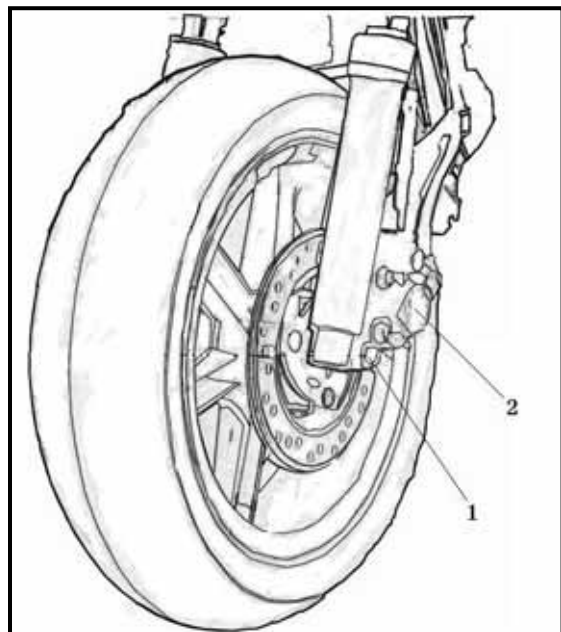

Place an appropriate supporting stand under the engine in order to raise the front wheel up.

Loose the mounting bolt( 1 )which fixing the axle of the front wheel,in order to remove the front wheel and its axle.

Remove components of the gear seat

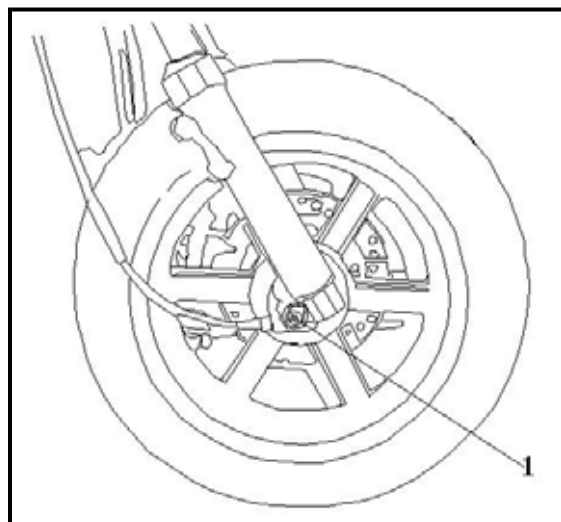

Remove the braking disk

Remove axle sheath, oil seal, axle (6201-2RS),

axle insulating sheath, axle(6201-2RS).

**\*Note : see P87 for figure RACE 50 for dismantling and mounting front wheel.**

## 7.3.2 Inspection

### 7.3.2.1 Inspect bending of the wheel spindle

Put the wheel axle on a V-shape seat and use dial indicator to measure its excentricity.

**Allowable limit : if the value exceeds 2.0mm, replace the rim.**

### 7.3.2.2 Inspect yawing of rim

Put the wheel ring on an accurate bracket, and examine its swinging degree.  
Rotate the wheel by hand, and read the swing degree.

**Allowable limit :**

**Vertical orientation : if the value exceeds 2.0mm, replace the rim.**

**Transverse direction : if the value exceeds 2.0mm, replace the rim.**

### 7.3.2.3 Inspect the front wheel bearing

Remove front wheel axle, braking disk.  
Remove front wheel left axle sheath, then remove the oil seal.  
Remove the axle.

Examine the rolling condition of the bearing.  
If it doesn't roll, or the bearing is damaged or loosened, it should be replaced by new product.

## 7.3.3 Replace the bearing

After Dismantling the front wheel axle, front wheel as well as the intermediate axle sleeve and the left axle sleeve

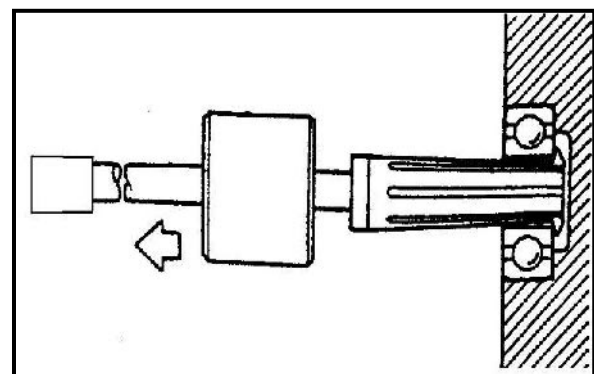
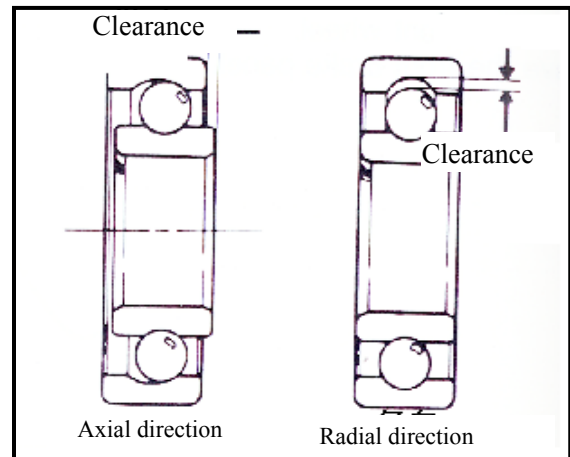
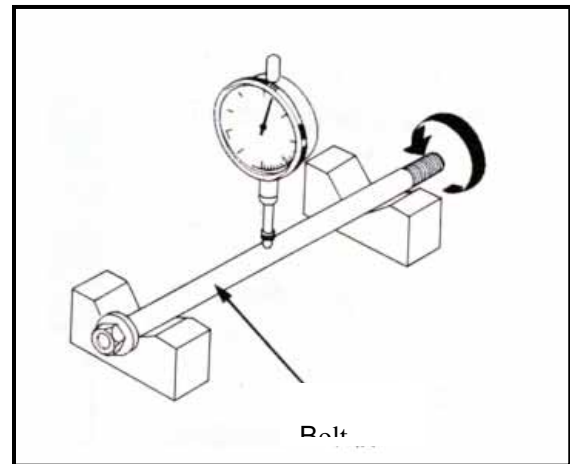

of the front wheel, dismantle the oil seal and bearing by using the oil seal puller and bearing puller respectively.

**Note: the dismantled bearings should be replaced with new ones.**

During the installation, smear grease lubricant on the bearings.

Then drive in the bearings by bearing installation tools.

**\*Attention**

- The bearing must be punched in horizontally.

**7.3.4 Installation**

Mounting should follow the reversed procedure of dismantling and pay attention to the following items :

lubricate front axle, components of gear seat, oil seal(interface), axle sheath, axle(6201-2RS), axle insulating sheath.

Recommended lubricant is grease of calcium radicle first. Mount front wheel axle(8), front wheel, components of gear seat(10), Bolts M12X1.25(7).

Make certain that the joint position is matched well when mounting components of gear seat and odometer gear seat.

If those components are not jointed and locked tightly when mounting, they will distort in the future.

Mount the braking cylinder to the front wheel hub.

Screw down the front wheel axle ( as the figure of right side )

**\* Note : see P87 for figure RACE 50 for dismantling and mounting front wheel.**

**Value of Torsion :**

**Blot for screwing down the front wheel axle 100-113**

**N·m**

**7.4 Steering bar**

**7.4.1 Dissemble**

Remove components of back mirrors.

Remove bolts for fixing ornament lid of the upside and downside cover of the steering bar.

Remove the upside ornament lid, and then remove meters.

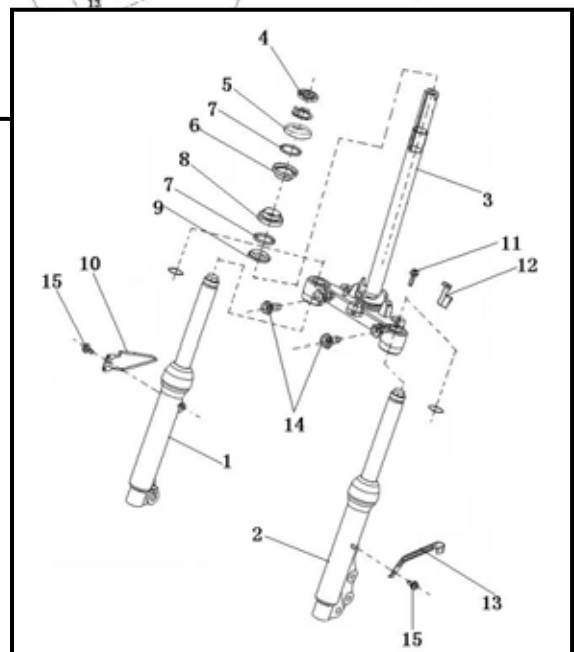
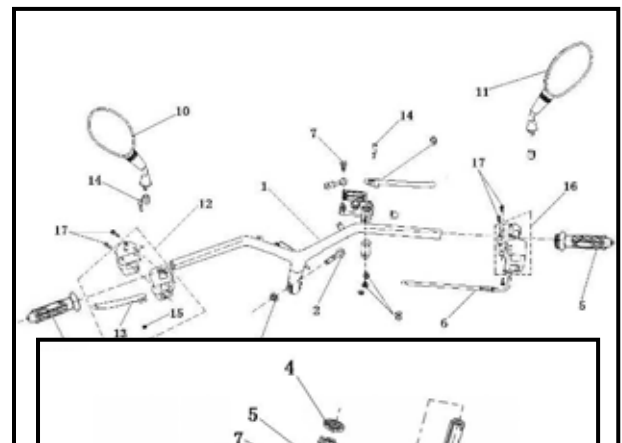
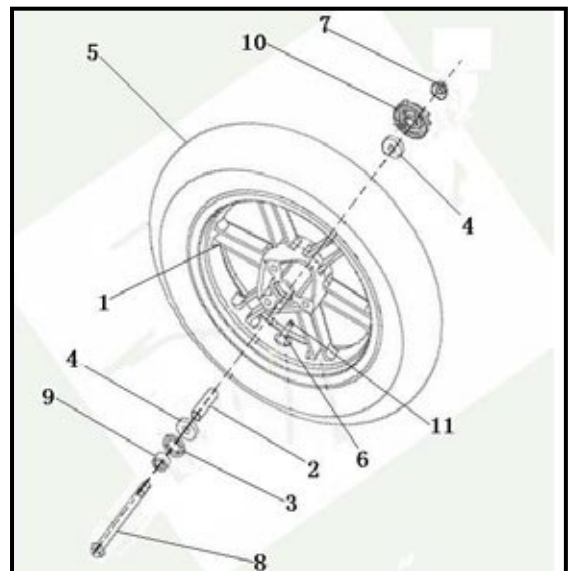

Remove components of the front cover.  
Remove components of left/right switch combination.  
Remove components of fuel pump.  
Remove the left holding bar, and components of the fuel control bar.  
Loose screw bolts of welded components of the steering bar.  
Remove the welded components of the steering bar.

## 7.4.2 Installation

**\*Note : see P88 for figure for dismantling and mounting steering bar.**

Mounting should follow the reversed procedure of dismantling.

Screw bolts of welded components of the steering bar

**Value of Torsion : 40-60 N·m**

## 7.5 Front fork

### 7.5.1 Disassembly

Disassemble the front wheel.  
Remove the shielding plate for vehicle body.  
Remove braking fluid tube, wires of odometer.  
Remove steering bar.  
Remove in sequence the fastening bolts ( 4 ) , anti-sliding washer.  
Remove the upside and downside steel bowl and steel balls ( 7 ) of the upside axle.  
Remove the front fork.  
Remove the upside and downside steel bowl ( 8, 9 ) and steel balls ( 7 ) of the downside axle.  
Loose screw bolts of front shock absorber, and springs.  
Remove both left and right components ( 1, 2 ) of front shock absorber.

Tools :

Wrench for screw bolts of welded components of the steering bar.

Fixing nut spanner.

Specific dismounting tools for bearing steel bowl.

### **\*Attention**

Clean the opening part of the body guard board with rags.

Use specialized tools for dismantling the upside and downside steel bowl of axle.

### 7.5.3 Installation

Lubricate the downside axle steel bowl with grease and confirm the amounts of steel balls. ( 21pcs )

Don't rotate the steering bar when the steering bar is not completely mounted ( to avoid falling of steel balls).  
Support the steering bar well, lubricate the upside axle steel bowl with grease and confirm the amounts of steel balls.

( 21pcs )

Lubricate the seat ring of top seat with grease.

Rotate the steering bar left and right to make steel balls contacted closely.

Tools:

Wrench for screw bolts.

Confirm smoothly sliding of front fork without any loose.

Mounting procedure :

Mount components of front shock absorber.

Mount steering bar.

Mount the shielding plate of vehicle body.

Mount front wheel.

**Note : see P89 for figure for dismantling and mounting front fork.**

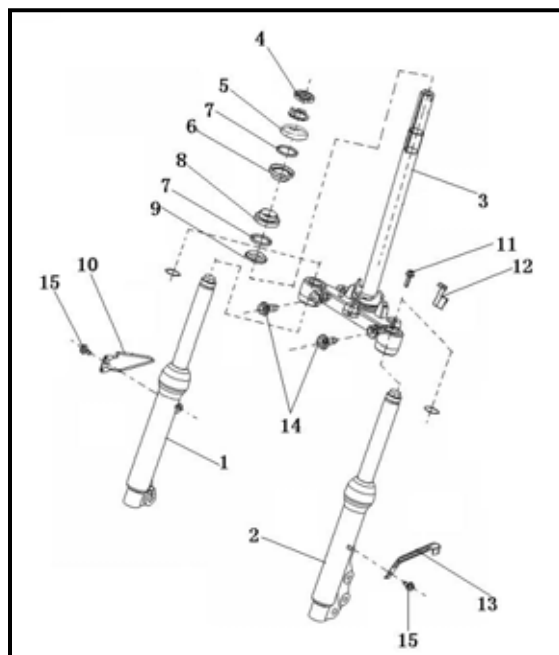

## Rear wheel /rear suspension

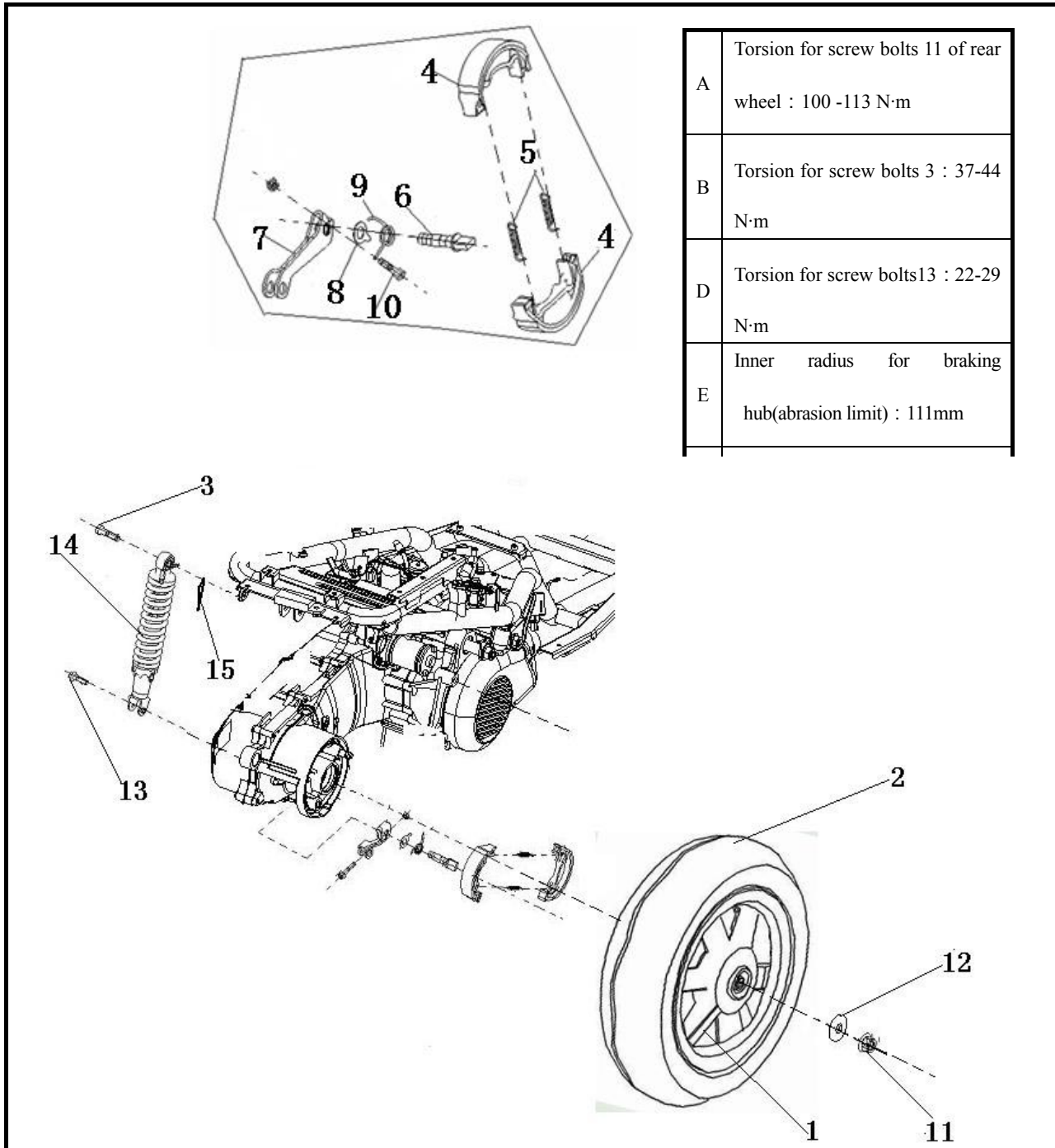

1 Rim 2 tyre 130/70-12 3 screw M10×1.25×40 4 components of braking plate 5 tension spring of braking plate 6 camshaft of rear brake 7 crank components of rear brake 8 rear indicator 9 position return spring of rear brake 10 mounting bolts of rear crank 11 bolts 12 dust proof lid 13 screw M8×31 14 components of rear shock absorber 15 locking pin

# Real wheel

A	Specification of outer tire : 130/70-12
B	Speciation of rim : 3.50×12
C	Wobbling limit :
	Vertical : 2.0mm Horizontal : 2.0mm
D	Torsion for screw bolts 11 of rear wheel : 100-113N·m

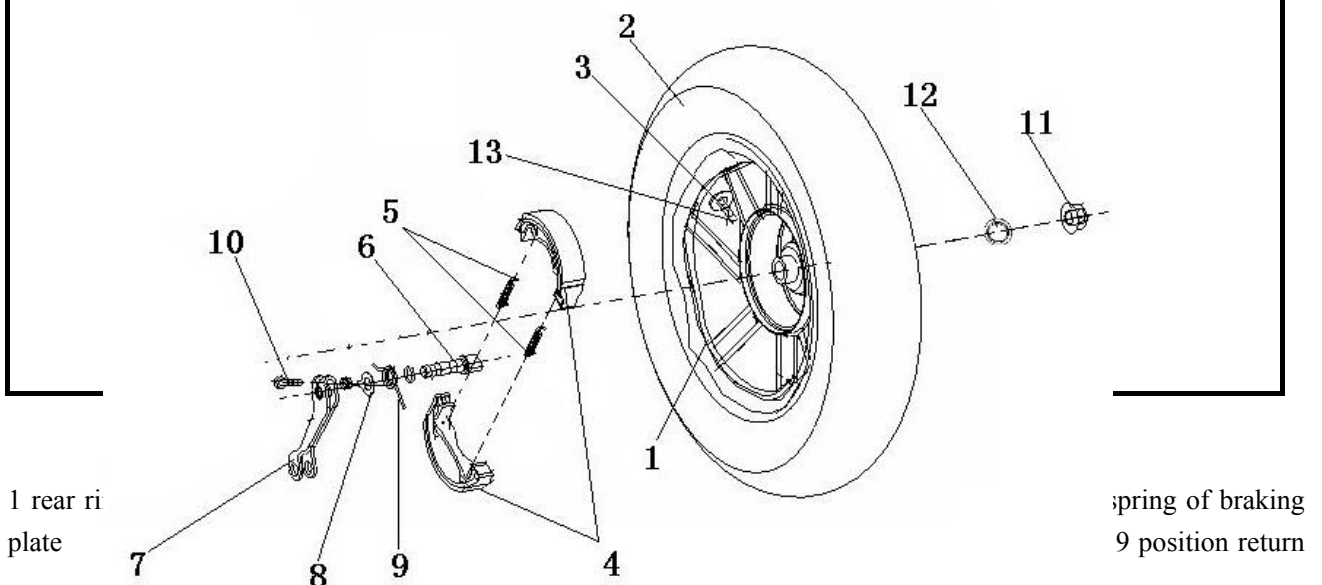





The tire pressure is not enough

### 8.2.2 Shock absorber too soft

Elasticity fatigue of spring

## 8.3 Real wheel

### 8.3.1 Disassembly

Remove muffler components ( 1 ) .

Remove rear inner mudguard.

Remove screw bolts of rear wheel axle.

Remove rear wheel components ( 2 ) .

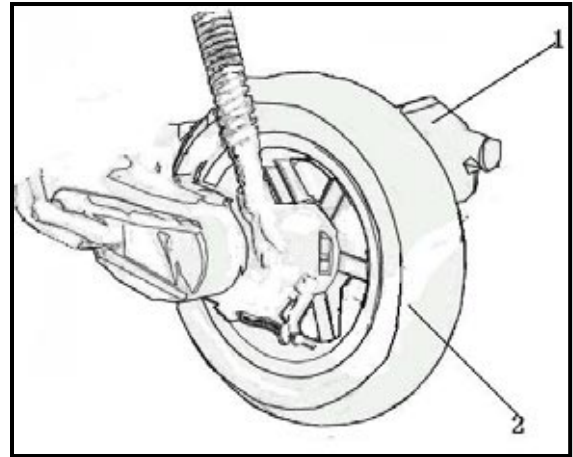

### 8.3.2 Inspection

#### 8.3.2.1 an examination on the swinging of wheel ring

Rotate the wheel by hand, and measure the eccentricity through the dial gauge.

**Allowable limit :**

**Vertical direction : Replace for that is above 2.0mm.**

**Transverse direction : Replace for that is above 2.0mm.**

When the swinging degree of the rear wheel exceeds the allowable limit, the rear wheel bearing becomes flexible, which leading to the swinging of the rear wheel. Replace the rear wheel bearings with new ones after an examination.

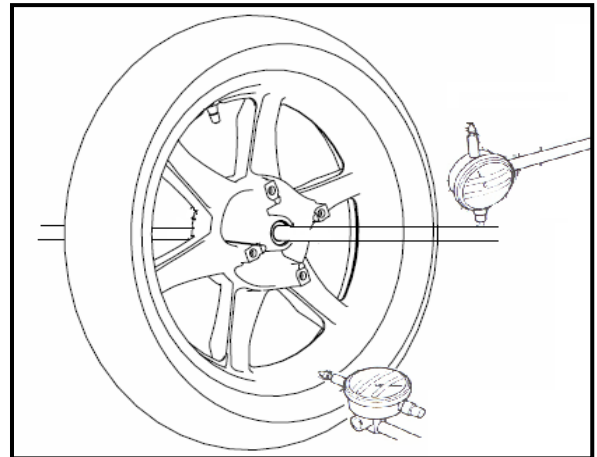

### 8.3.3 Installation

Carry out the installation of the rear wheel according to a reversed sequence of dismantle., and then tighten the nuts.

**Rear wheel fixed nut**

**Torque value : 100-113 N·m**

## Rear wheel

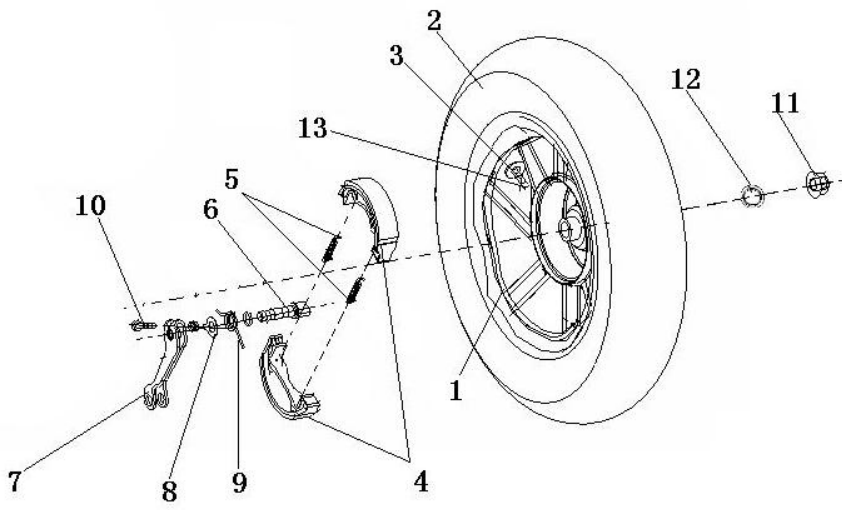

## 8.4 Rear shock absorber

## 8.4 Rear shock absorber

### 8.4.1 Disassembly

Dismantle the cushion, the left-rear guard plate and the right-rear guard plate.

Dismantle the rear handrail and the rear mudguard.

Remove the fixing bolts of rear shock absorber.

Unload the rear shock absorber.

### 8.4.2 Installation

Install the rear shock absorber.

**Torque value :**

**Upper fixing bolt : 37-44 N·m**

**Lower fixing bolt : 22-29 N·m**

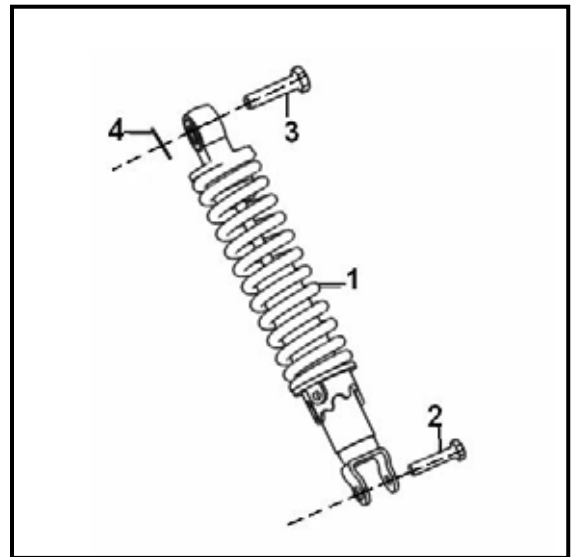

The installation of rear shock absorber.

The installation of rear handrail and the rear mudguard.

The installation of cushion, the left-rear guard plate and the right-rear guard plate.



## Fuel tank/seat mat

A	<b>Caution</b> : must turn the fuel switch to the “OFF”position when dismantling the fuel tank
B	Torsion for bolts 4 : 37-44 N·m
D	Torsion for screw 10 : 5-9 N·m

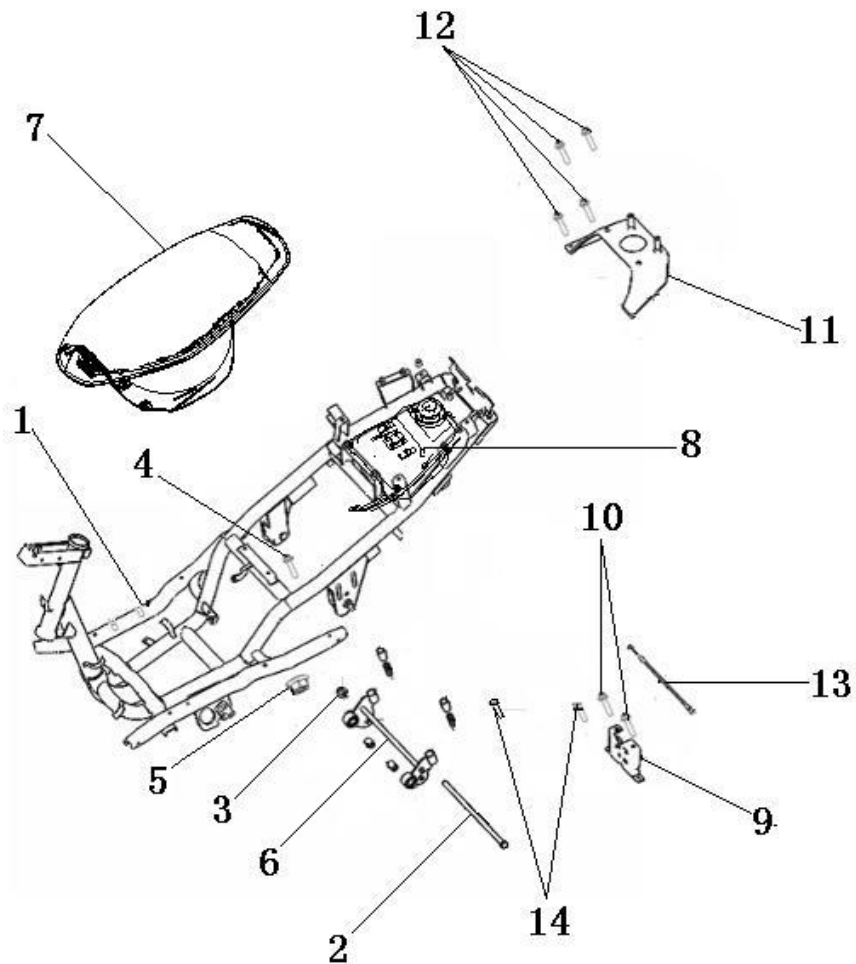

1 welded components for vehicle frame    2 screw axle for engine    3 bolts M12×1.25    4 screw bolts for hanging rack M10×41×1.25    5 bolts M10×1.25    6 welded components for welded components of power

output hanging rack 7 seat mat assembly 8 fuel tank assembly 9 components of seat mat lock 10 screw M6×20 11 prop for rear luggage rack 12 screw M6×12 13 tight wire of seat mat 14 rivet 3.2×7

## Fuel tank

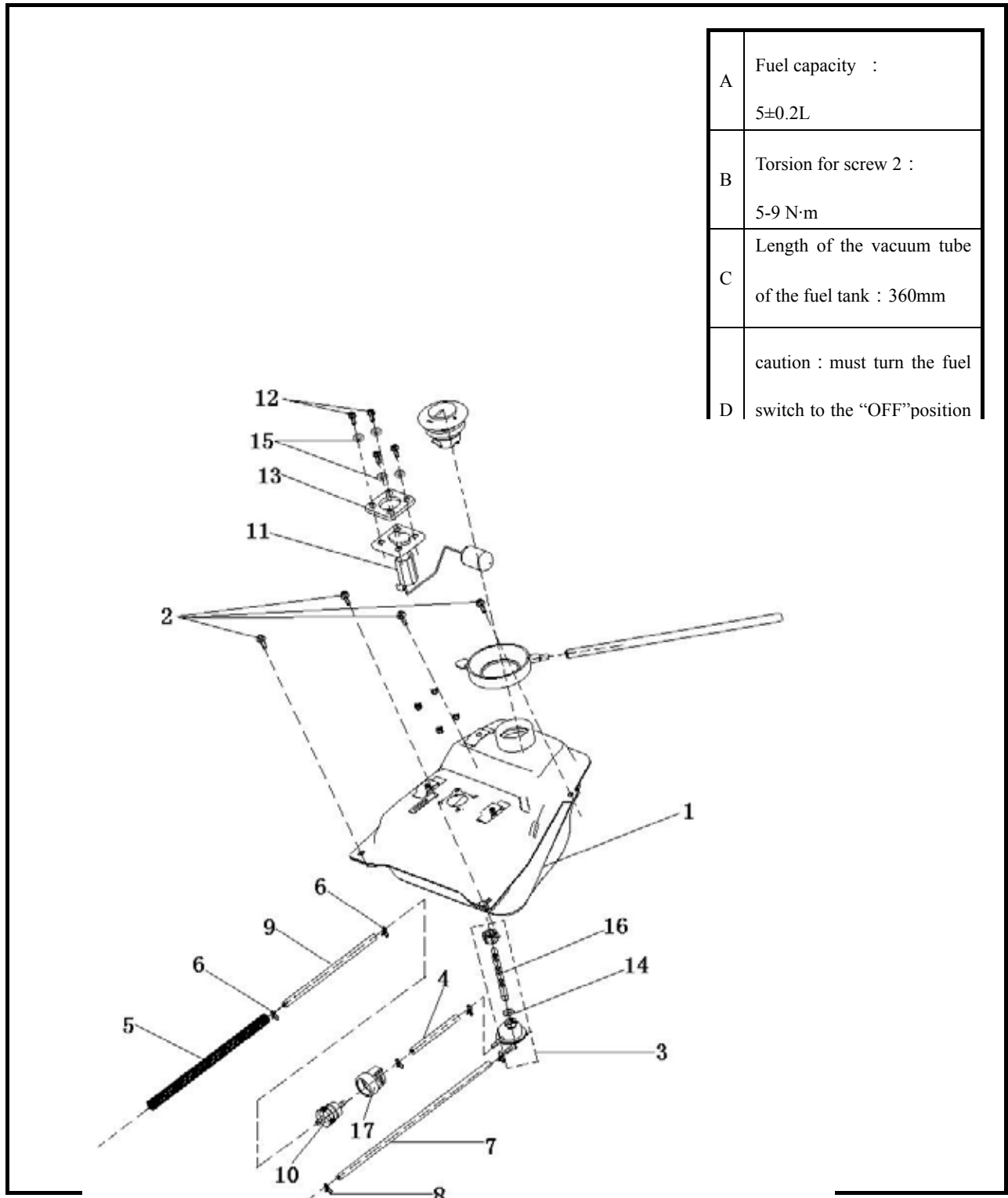

1 tank components    2 screw M6×16    3 components of fuel tank switch    4 fuel tube 180mm    5 heat insulation spring  
 6 hoopΦ8    7 vacuum tube 360mm    8 hoopΦ7    9 fuel tube 2250mm    10 filter components  
 11 fuel position sensor    12 screw M5×16    13 gasket of fuel position sensor    14 seal rubber  
 15 gasket 5    16 filter core    17 sheath gasket

## Seat mat

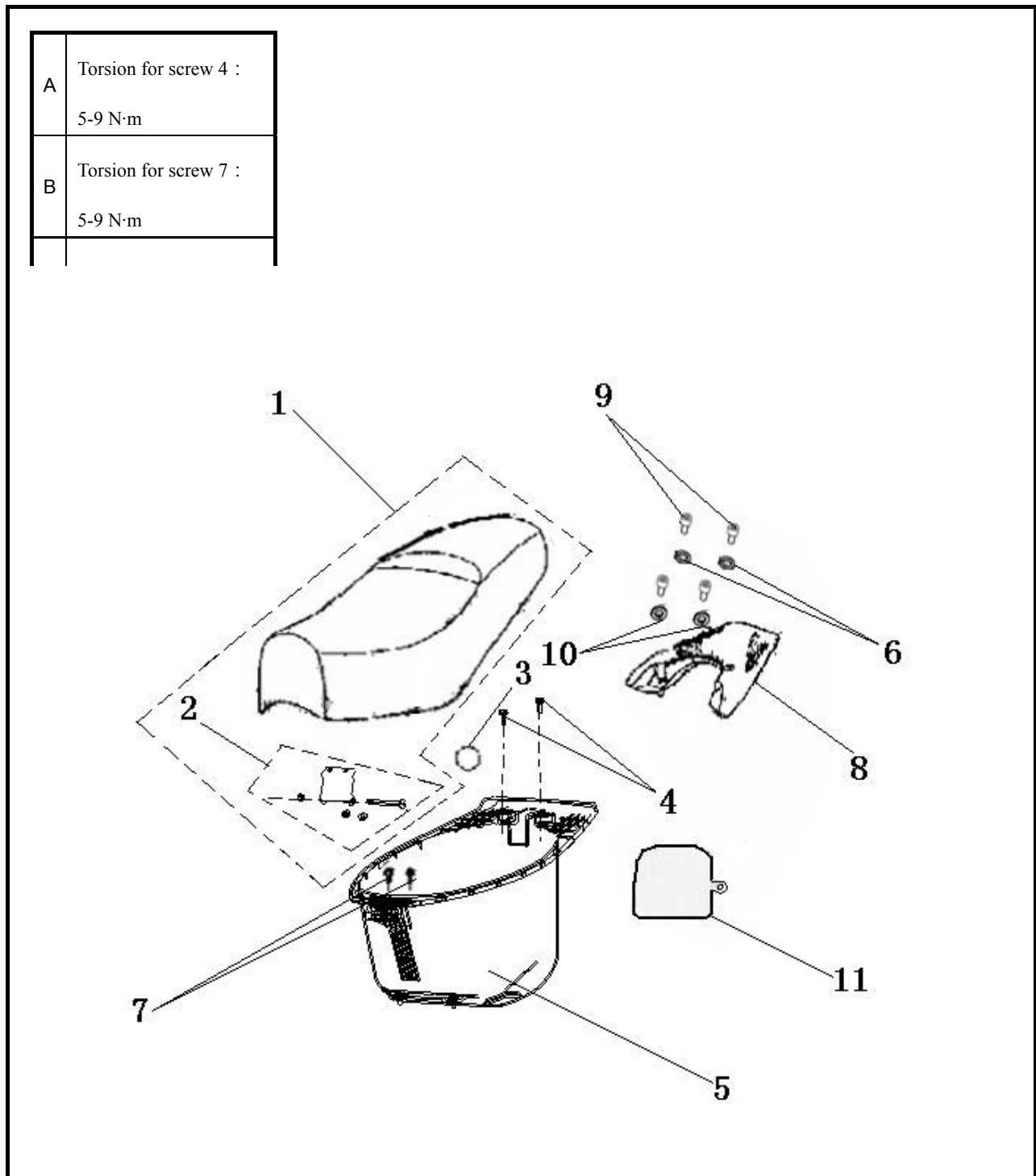



1 components of seat mat 2 components of rotating leaf 3 O shape ring 84.4×3.1 4 protruding screw M6×14 5 helmet bucket 6 gasket 7 screw M6×12 8 rear luggage rack 9 screw nail M8×45 10 plastic gasket 11 bottom lid of helmet bucket

## IX. Fuel tank/seat mat

Preparation-----9.1

Troubleshooting-----9.2

Fuel tank/seat mat-----9.3

### 9.1 Preparation

#### Matters needing attention in operation

The place for dismantling should be far away from fire.

must turn the fuel switch to the “OFF” position when dismantling the fuel tank.

Torsion for screwing bolts must meet the determined value.

Check whether all parts are properly mounted and operating after mounting..

#### Preparation reference

Item	Standard	Limit for usage
Fuel tank capacity	5±0.2L	/

#### Torsion for screwing down

Screw bolts for rear luggage rack prop 5 - 9 N·m

Screw bolts for fuel tank 5 - 9 N·m

Screw bolts for helmet bucket 5 - 9 N·m

### 9.2 Troubleshooting

#### Decrease of fuel quantity

Normal consuming of fuel  
Leakage of fuel

### 9.3 Fuel tank/seat mat

#### 9.3.1 Disassembly

Open seat mat.

Remove the screw bolts of seat mat ( 4 pcs ) .

Remove oil pot shielding lid.

Remove oil pot.

Remove seat mat ( 7 ) and helmet bucket.

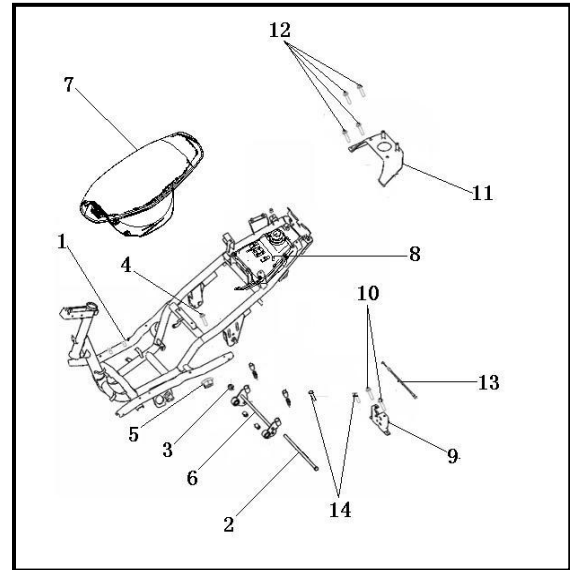

Remove rear luggage rack ( 8 ) .

Remove left/right shielding plate.

Remove components of rear handrail and helmet bucket mounting seat.

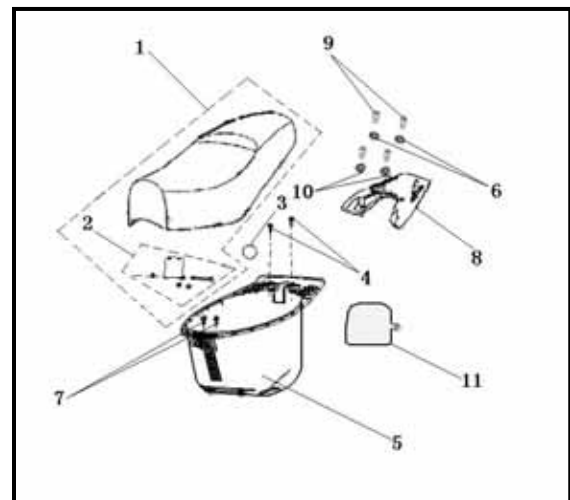

Turn the fuel switch to “OFF” position.

disconnect : fuel tube.

Remove the fuel tank from vehicle frame.

**Note :**

see P100, 101, 102 for detailed figure of dismantling and mounting.

### 9.3.1 Installation

Mounting should follow the reversed procedure of dismantling.

**Torsion for mounting :**

**Screw bolts for rear luggage rack prop      5 - 9 N·m**

**Screw bolts for fuel tank                              5 - 9 N·m**

**Screw bolts for helmet bucket                      5 - 9 N·m**

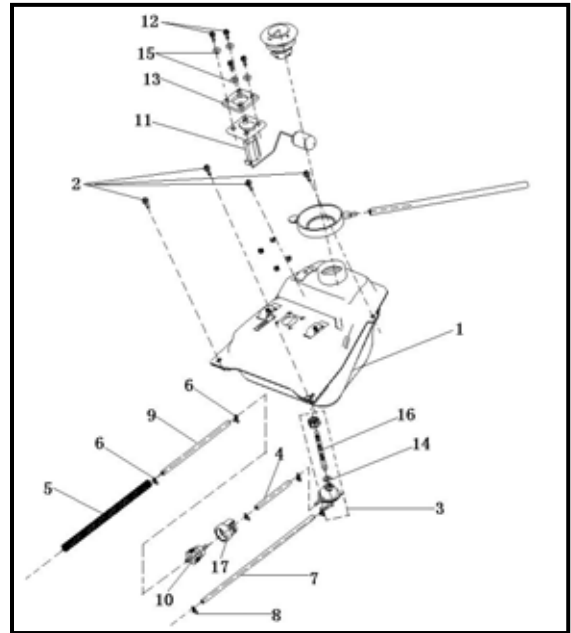

## Inspection and maintenance of engine

**Table of torque value of engine fastener**

Fastening area and fastener name	Tightening torque ( N·m )
----------------------------------	---------------------------

	10-12
	15-18
	22-25
<b>Lock bolt Of Shroud</b>	10-12
<b>Lock nut of cylinder cover</b>	10-12
<b>Spark plug</b>	10-12
<b>Air intake tube screw bolt</b>	45-50
<b>Cooling fan impeller screw bolt</b>	10-12
<b>Fly wheel screw bolt</b>	10-12
<b>Screw nail of stator of Magnetic motor</b>	10-12
<b>Right crank box screw bolt</b>	10-12
<b>Axle tightening plate screw bolt</b>	15-18
<b>Cylinder Twin cap screw</b>	10-12
<b>Motor screw bolt</b>	10-12
<b>Crank box left lid cover screw bolt</b>	10-12
<b>Crank box left cover screw bolt</b>	10-12
<b>Driving hub screw bolt</b>	40-45
<b>Idling hub screw bolt</b>	40-45
<b>Idling hub clutch screw bolt</b>	55-60
<b>Surpassing Clutch outer ring screw bolt</b>	10-12
<b>idling wheel of Electric starting tightening plate screw bolt</b>	10-12
<b>Gear box lid screw bolt</b>	18-22
<b>Left crank box oil releasing screw bolt</b>	18-22
<b>Left crank box positioning pin axle screw bolt</b>	



# Lubrication system

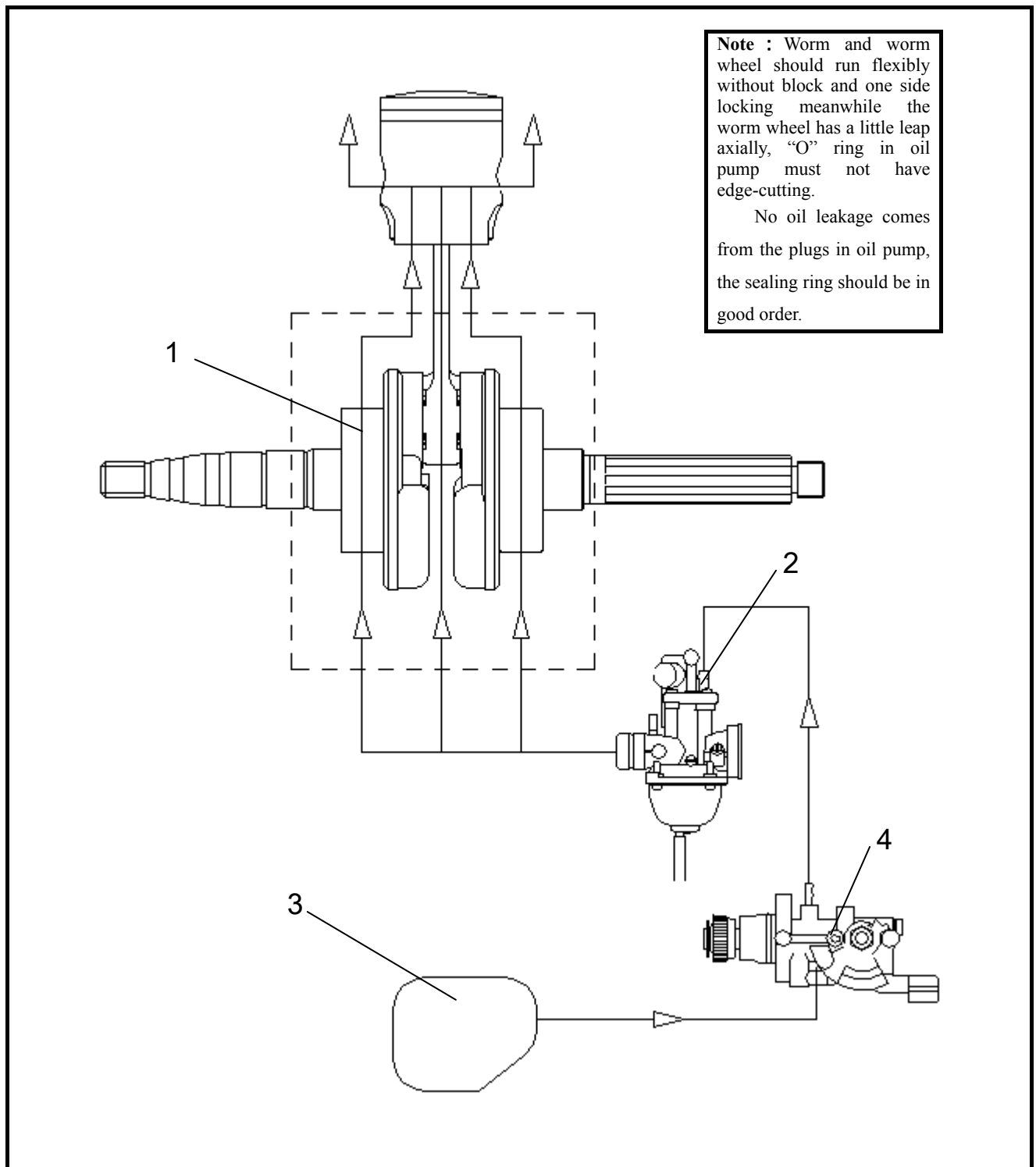

1. Crankcase. 2. Carburetor. 3. Oil tank. 4. Oil pump

## X. Lubrication system

Preparation data -----10.1

Fault diagnosis -----10.2

Oil pump -----10.3

### 10.1 Preparation data

#### Matters needing attention in operation

Worm and worm wheel should run flexibly without block and one side locking meanwhile the worm wheel has a little leap axially, “O” ring in oil pump must not have edge-cutting.

No oil leakage comes from the plugs in oil pump, the sealing ring should be in good order.

Bolt 3 should be dismantled during the engine trial operation after assembling, retighten it firmly till to the oil flowing out to be seen.

**Function of the lubrication system** : supplying lubricating oil to the wear surface to reduce part wear by turning dry friction between surfaces into liquid friction between lubricating oil particles ; cooling high-load parts ; absorbing impact from the bearing and other parts and reducing noises ; increasing air tightness between the piston ring and cylinder wall ; cleaning and carrying away impurities on part surfaces.

#### Preparation reference

Item		Standard	Permitted limit
machine oil capacity	when changing the oil	0.1L	/
	when dismantling	0.11L	/



## 10.2 Fault diagnosis

### Decrease of machine oil

Natural loss of machine oil

Machine oil leak

Wear and improper installation of the piston ring

### Engine burnt out

Absence of oil or oil pressure too low

Oil path blocked

Machine oil not used

## 10.3 Oil pump

### 10.3.1 Disassembly

Loosen the fixed bolt, and take off the chain cover.

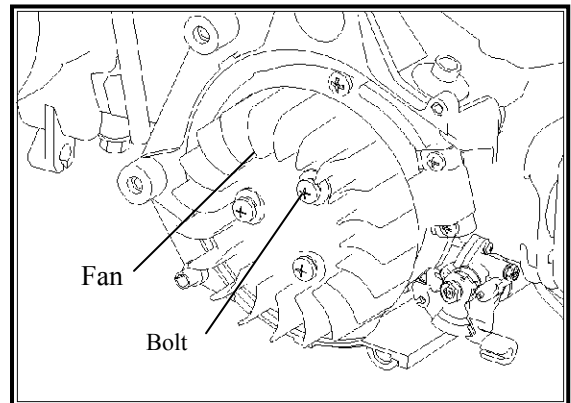
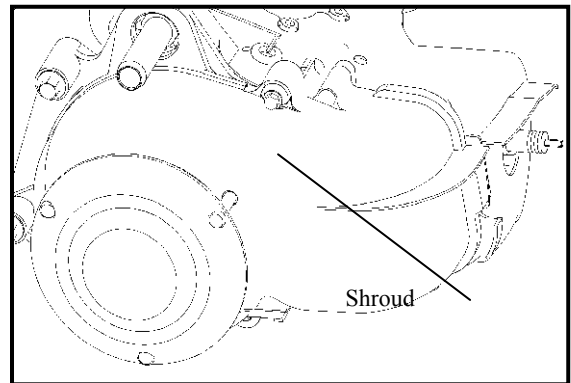

Loosen the screws on the fan, take off the fan.

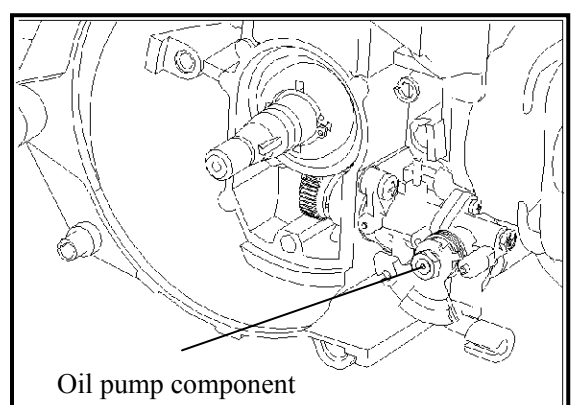
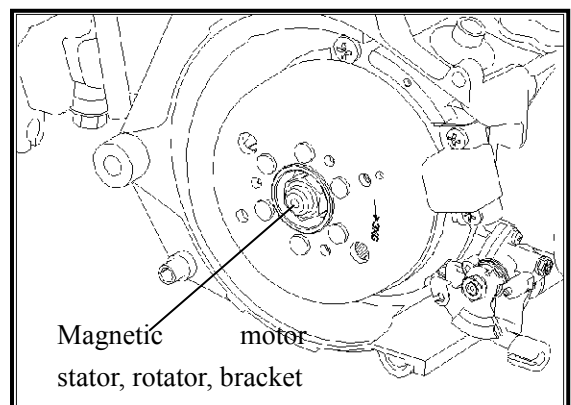

Take off the magnetic motor stator, rotator and bracket.

Take off worm wheel from the crankshaft, take off oil pump component.

## Oil pump assembling

Shown in the following Fig.

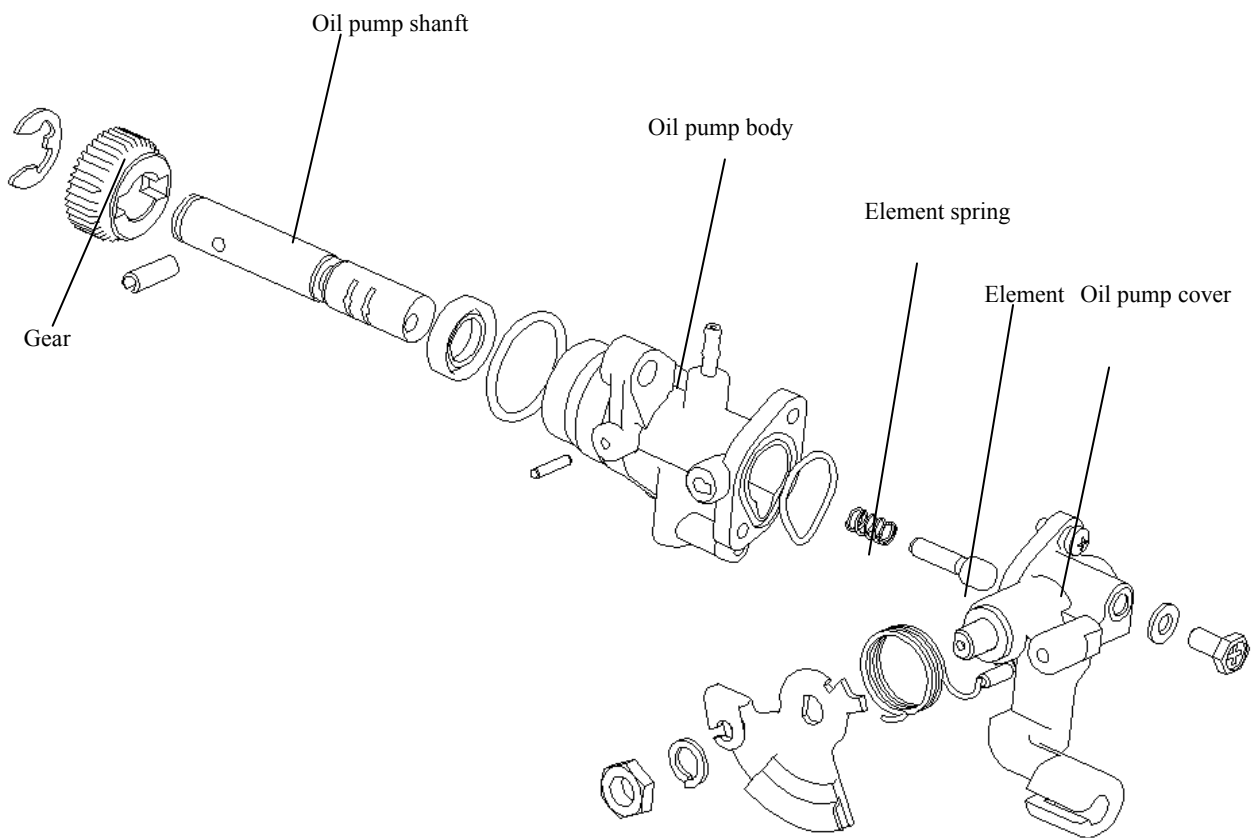

### 10.3.2 Installation

Carry out the installation according to the reversed sequence of dismantle.

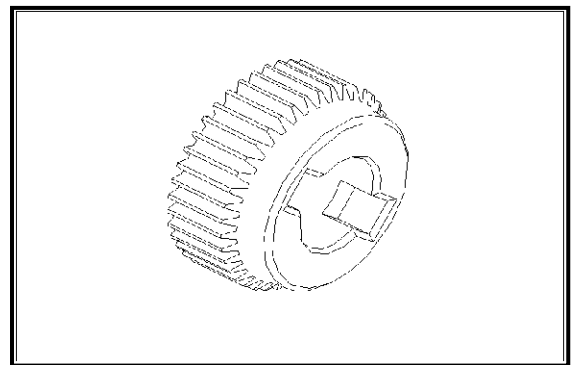

### 10.3.3 Inspection

Inspect worm wheel teeth surface whether there is damage.  
Inspect key slot whether there is breakage.

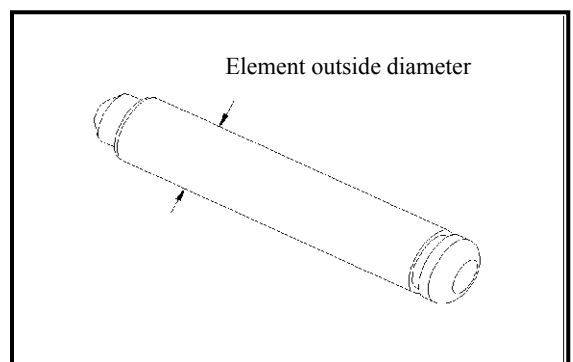

Measure element outside diameter.

**Allowable limit :2.61mm.**

## **Carburetor**

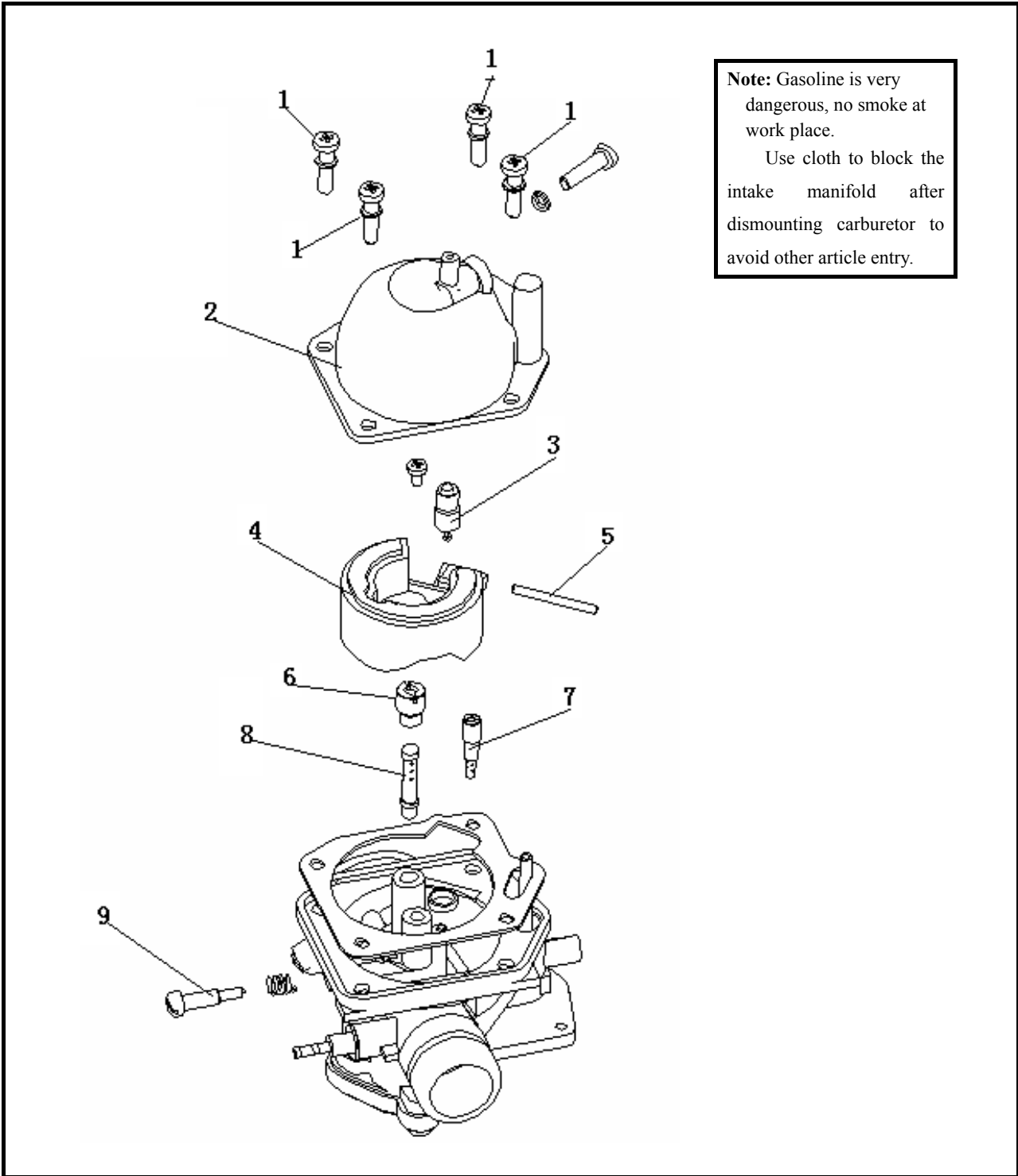

1. Screw.    2. Float chamber    3. Needle-valve component.    4. Floater.    5. Floater pin    6. Main jet.  
7. Idle speed injection nozzle.    8. Main foam pipe.    9. Idle speed adjusting screw.

## XI. Carburetor

Preparation data-----	11.1
Fault diagnosis-----	11.2
Disassembly of carburetor-----	11.3
Installation of carburetor -----	11.4
Adjustment of carburetor -----	11.5

### 11.1 Preparation data

#### Matters needing attention in operation

- Gasoline is extremely dangerous , so smoking or lighting is strictly forbidden in operational field.
- Pay special attention to flakes.
- No wire should be pulled and bent with rudeness. Distortion or damage will have impact on wire actuation.
- After the carburetor is disassembled , choke the intake manifold with clothing to prevent entry of foreign objects.
- If the carburetor is not in use for more than one month, the gasoline inside the float chamber must be discharged. Otherwise, the gasoline inside the float chamber will deteriorate and block the idle speed nozzle, resulting in insecurity of idle speed.

**Function of the carburetor :** The carburetor is a critical component in the fuel delivery system of the engine, the operating mode of which carries direct influence on the steady operation of the engine, its driving force and economical indicator. The carburetor atomizes a given amount of gasoline into mini drops, which then evenly mix with varying volumes of air to shape vaporous combustible mixture according to different operating conditions of engines, and supplied to the engine in time, in order to ensure normal continuous running of it.

#### Preparation reference

Unit : mm

Item	Standard value
Main nozzle	47.5
Main jet	80#
Idle jet	15#

## 11.2 Fault diagnosis

### Bad startup

- Carburetor short of fuel
- Gasoline filter blocked
- Gasoline pipe blocked
- Needle valve conglutination
- Bad adjustment of oil level

### Too much fuel in the engine

- Overfuel and oilflow
- Secondary air inlet of fuel system
- Fuel deterioration
- Bad operation of electric enrichment valve
- Idle system or choke system blocked

### Too dense gas mixture

- Bad operation of enrichment valve
- Bad operation of needle valve
- Too high oil level
- Oilflow in carburetor
- Air channel blocked
- Filth in air filter

### Startup difficulty , flameout after startup , unsteady idle speed

- Fuel system blockage
- Too dense or sparse gas mixture
- Secondary air inlet of suction system
- Bad idle adjustment
- Bad adjustment of oil volume
- Idle system or electric enrichment valve blocked

### Too sparse gas mixture

- Oil nozzle blocked
- Needle valve blocked
- Too low oil level
- Fuel system blocked
- Bad act of piston
- Secondary air inlet of suction system

### Intermittent flashover in acceleration

- Too sparse gas mixture

## 11.3 Disassembly of carburetor

### 11.3.1 Disassembly

- Turn the fuel control switch to “OFF”.
- Take away fuel delivery hose. Release throttle cable.
- Take away plug on the fuel hose end, drain out fuel from floater chamber into another case.
- Take away the connector from the electric enriching valve.
- Loosen the screws connecting the engine connector and air filter in carburetor, take out the carburetor from them.

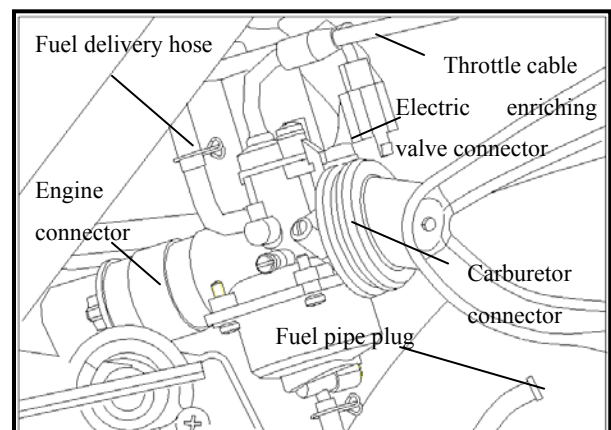





### 11.3.2 Decomposition of carburetor

Loosen the electric starting valve bolt, and take off the electric starting valve components.

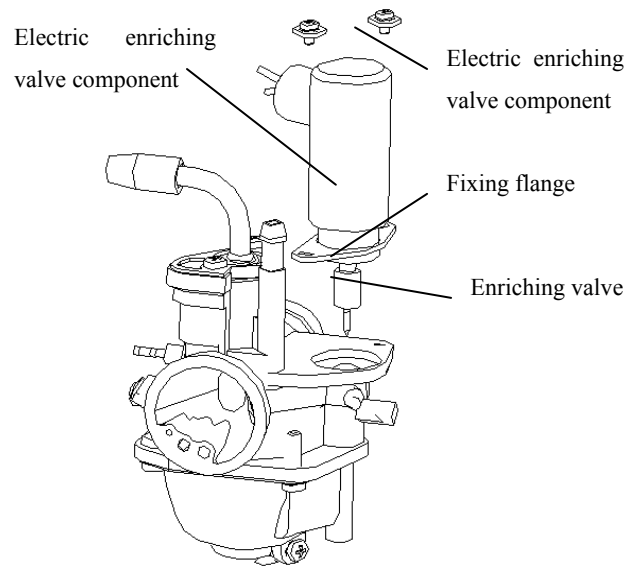

Examine the electric starting valve and the attrition condition of the needle valve.  
If the needle valve is seriously worn, electric starting valve components should be replaced.

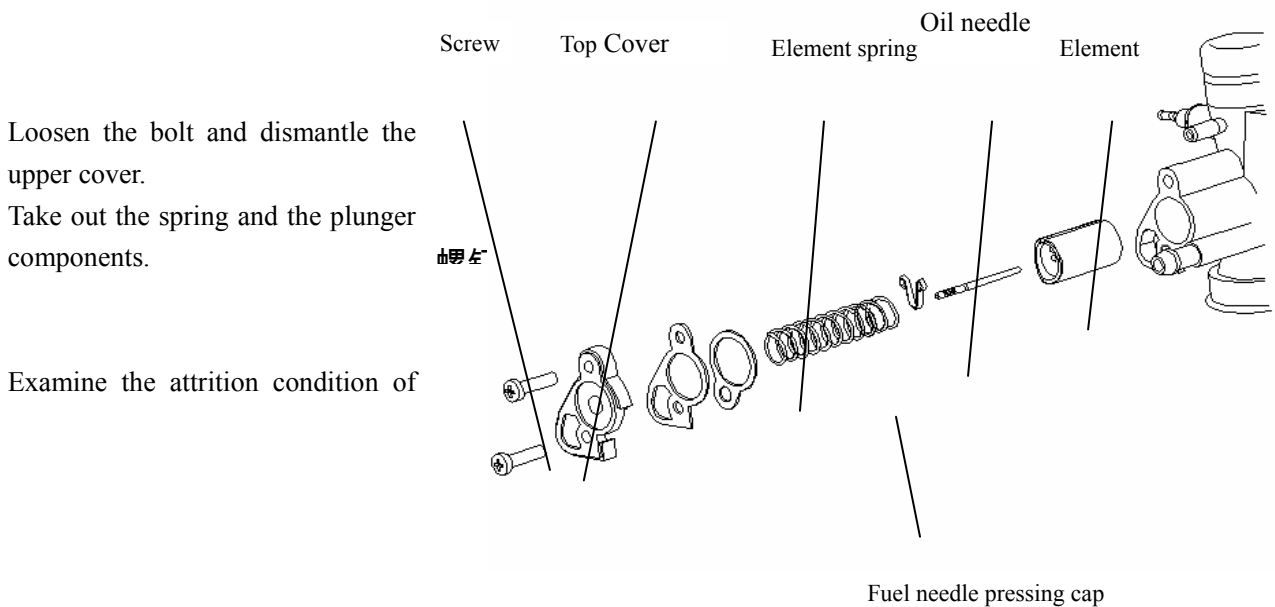

Loosen the bolt and dismantle the upper cover.  
Take out the spring and the plunger components.

Examine the attrition condition of

the plunger.

If the plunger is worn down, it should be replaced.

Examine the attrition condition of the needle valve.

If the needle valve is worn down, it should be replaced.

Loosen screws, take off the float chamber.

Dismantle the float components, floater-pin and needle valve component.

### 11.3.3 Examination

Examine if the needle valve core, needle valve and the float components are damaged or worn down .

If the needle valve core is damaged or worn down, it should be replaced.

If the needle valve seat is worn down, then the carburetor body should be replaced.

If the float tongue piece is worn down, it should be replaced.

Examine the oil needle of the carburetor to see if it is damaged or worn down. If so, the oil needle as well as the main nozzle should be replaced.

Examine the idle metering hole, the main metering hole and the main nozzle to see if they are damaged, worn down or stained. If so, they should be replaced.

Examine the plunger to see if it is worn down. If so, it should be replaced.

Examine the carburettor body and the oil-fired pipe. If they are stained, please clean them as per the instruction book.

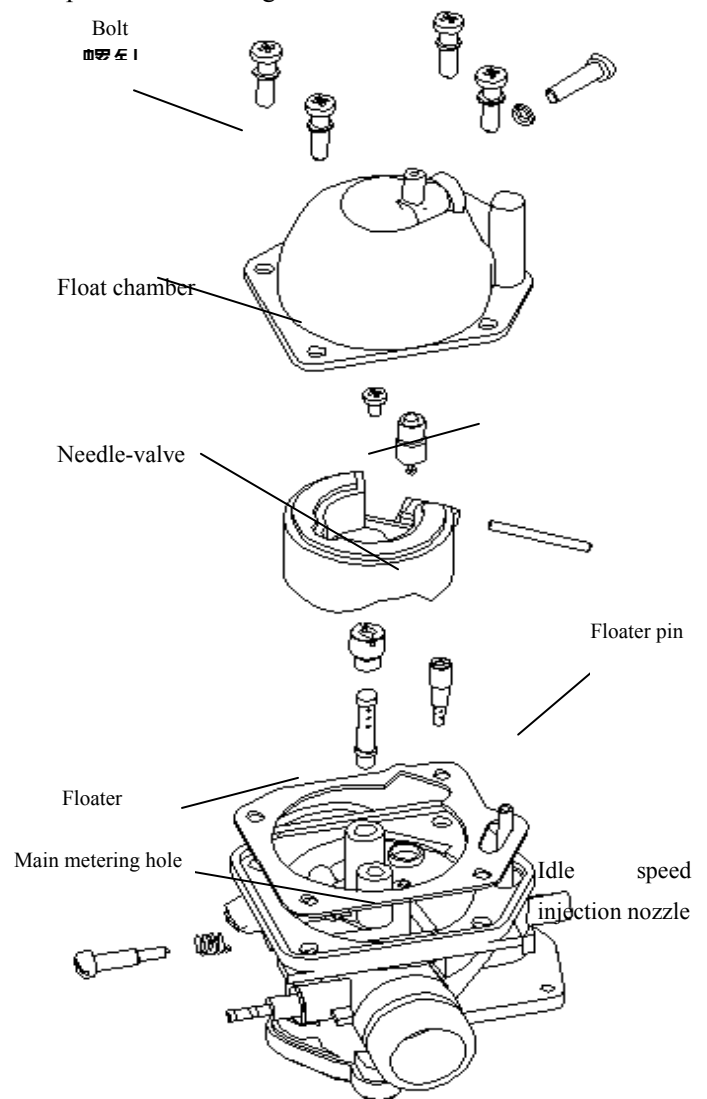

Idle speed  
injection nozzle

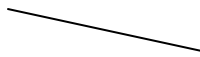
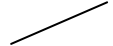

Idle adjusting screw



## 11.4 Installation & adjustment

Assembly and installation is conducted in the reverse order of disassembly.

### Adjustment of carburetor

**Attention:** When the carburetor is ready for sell, the idle adjusting bolts have already been adjusted, so they generally require no adjustment. When dismantling the carburetor, the number of turning of the bolts should be recorded which is very helpful during the installation.

Switch on and warm up the machine for about 3 minutes, so that the engine will operate in normal running temperature;

Adjust the idle adjustment bolts and set engine speed to be 1800rpm ;

Screw the mixture adjustment bolt to the end with proper force.

At this point the engine will stall( if not ,inspect whether air escapes at the interface of air filter , whether the bolt is tightened and whether the intake of the air filter is blocked);

Withdraw the mixture adjustment bolt for 1 circle;

Restart and adjust the idle adjustment screw so that the rotation speed reaches 2000-2500rpm;

Slowly adjust the mixture adjustment bolts( anticlockwise), till the engine speed reaches its utmost( mixture bolt is withdrawn for two circles at most ) .

Reset the idle adjustment screw and set the engine speed down to  $1500 \pm 100$ rpm/min.

Pull the throttle for several times for acceleration and inspect whether the idle speed is steady.

Test the outlet and compare it with the specified standards.

## Cylinder cover

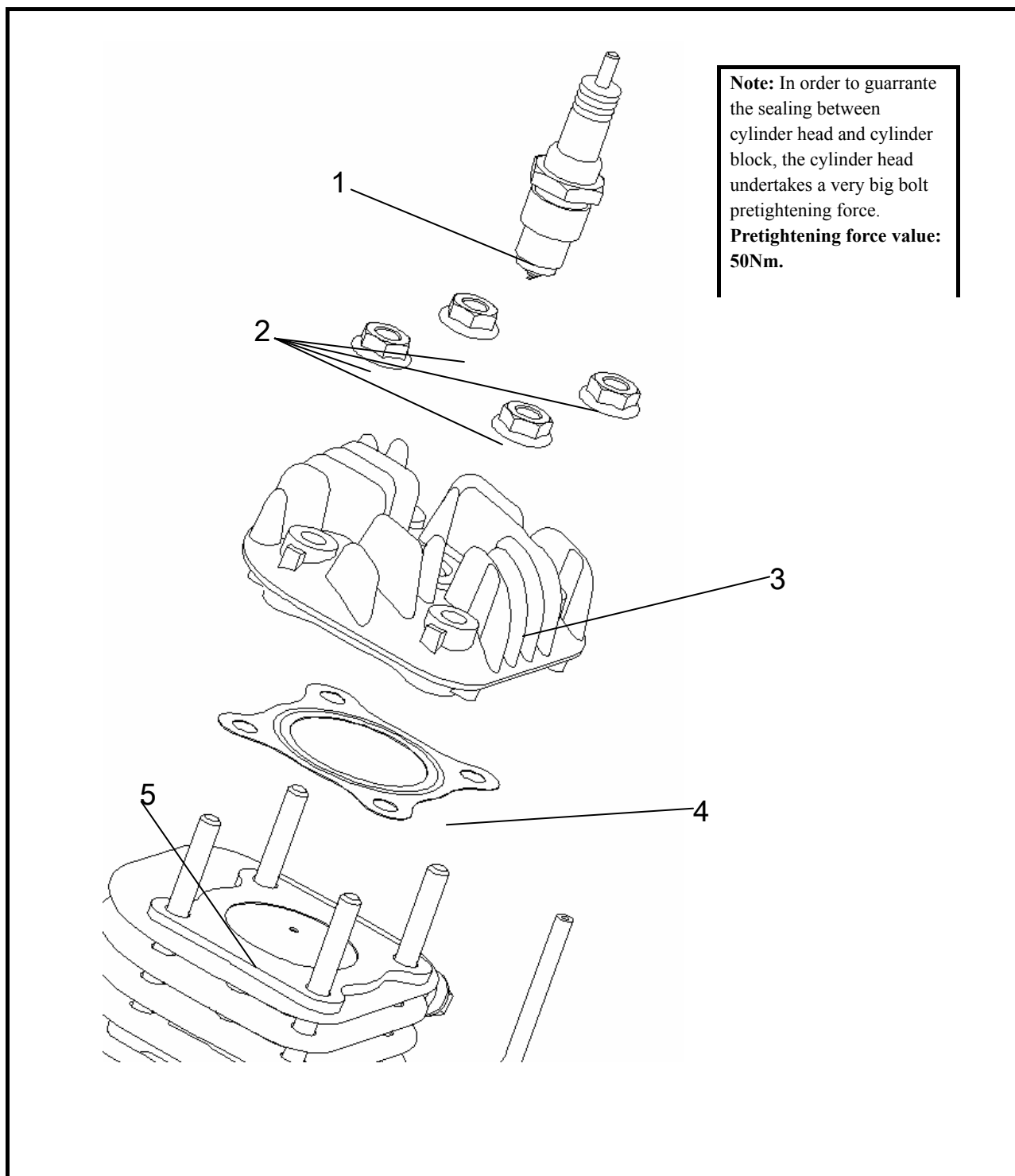

1. Spark plug. 2. Cylinder head fixing bolt. 3. Cylinder head. 4. Cylinder gasket. 5. Cylinder block.

## XII. Cylinder cover

Preparation data-----	12.1
Fault diagnosis-----	12.2
Cylinder head -----	12.3
Examination of the cylinder head-----	12.4
Installation of the cylinder head -----	12.5

### 12.1 Preparation data

#### Matters needing attention in operation

In order to guarantee the sealing between cylinder head and cylinder block, the cylinder head undertakes a very big bolt pretightening force. **Pretightening force value: 50Nm.**

All parts should be clean and blown clean by high compressed air before inspecting and measuring.

**The function of cylinder head:** The cylinder head which seals the cylinder block, consists of a combustion chamber with a piston, bears high temperature, high pressure gas and finishes intake and exhaust through the valve mechanism.

### 12.2 Fault diagnosis

#### Gas leakage between cylinder head and cylinder block or extra high combustion pressure

Cylinder head gasket breakage.

Cylinder head bottom plane warp

Combustion extra carbon deposit

### 12.3 Cylinder head

#### 12.3.1 Dismantle

Loosen shroud fixing bolt.

Dismount shroud.

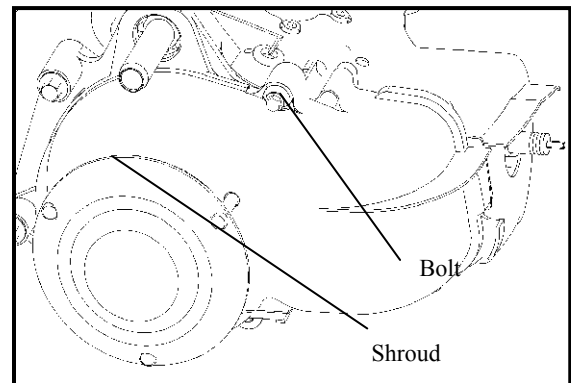

Loosen fixing nut and spark plug, dismount cylinder head.

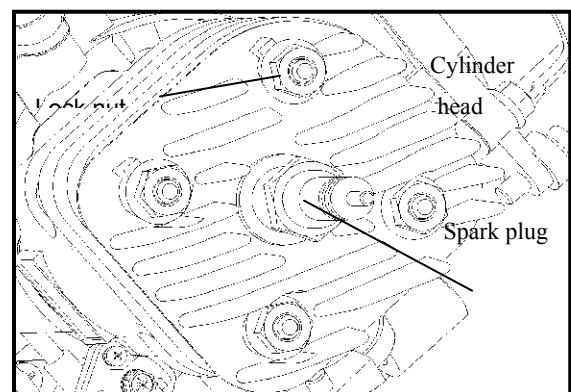



## 12.4 Examination on cylinder head

Inspect the cylinder head whether it is broken.

Inspect the planeness of the cylinder head bottom plane.

**Allowable limit : 0.04mm.**

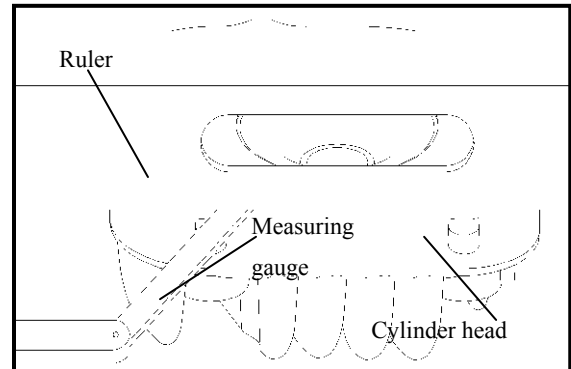

## 12.5 Cylinder head installation

Implement mounting in a reverse order with dismounting.

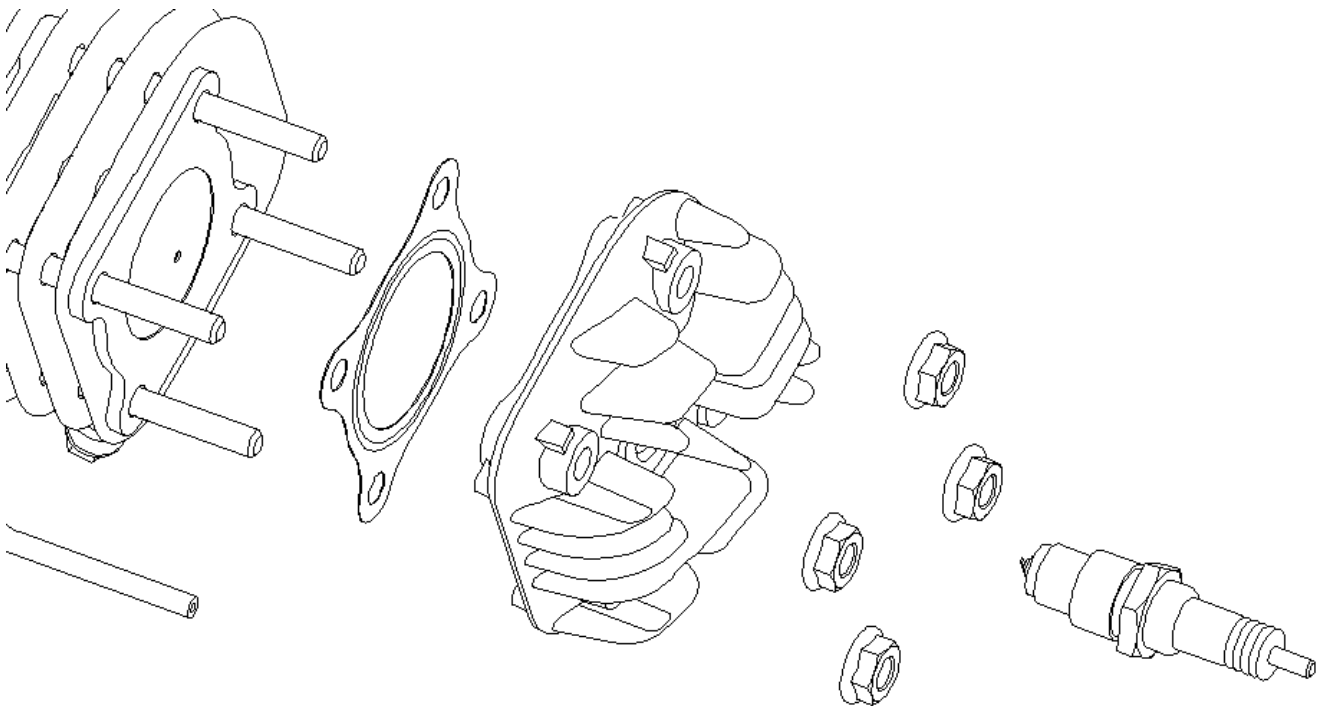



## **Air cylinder/piston**

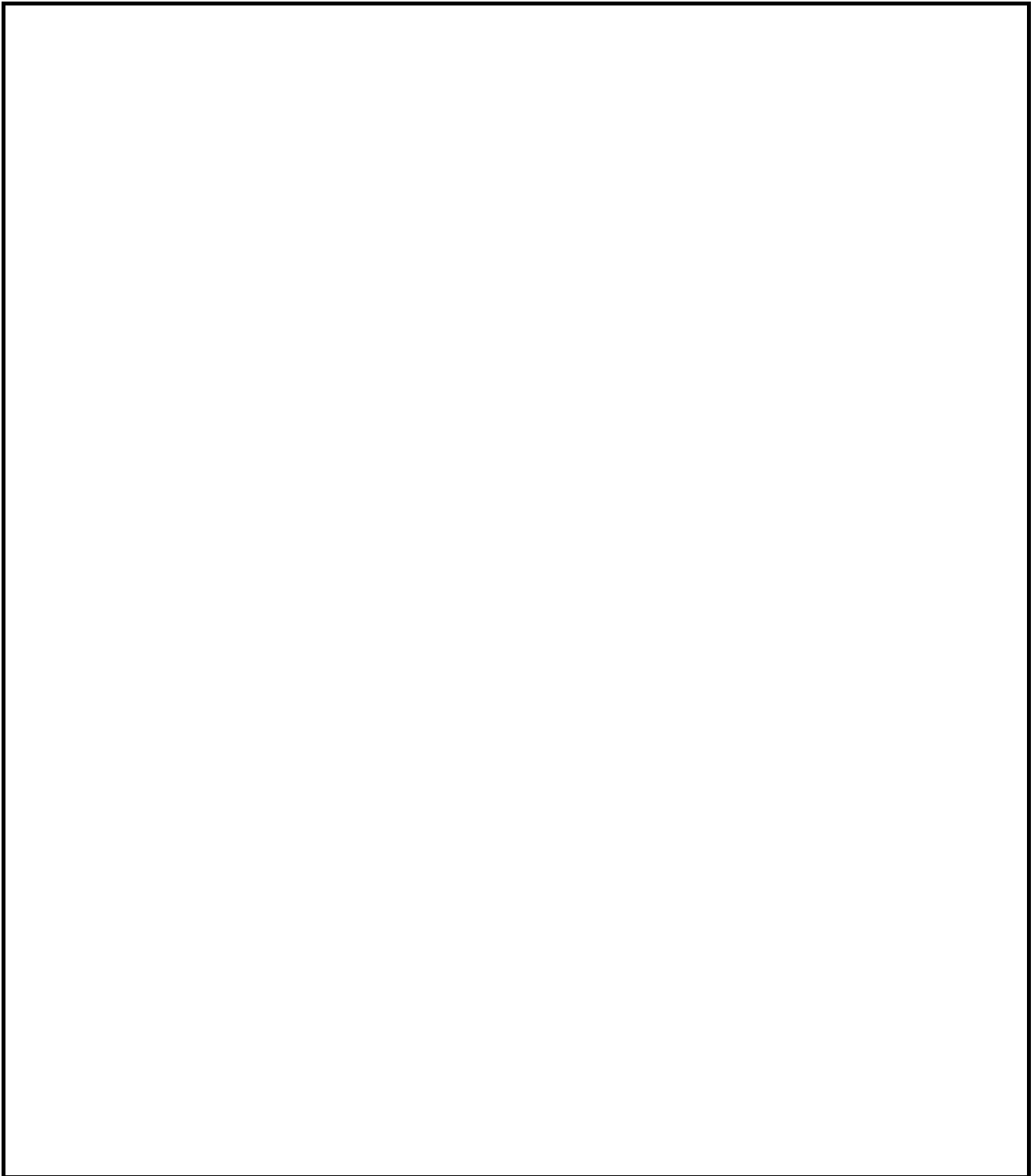

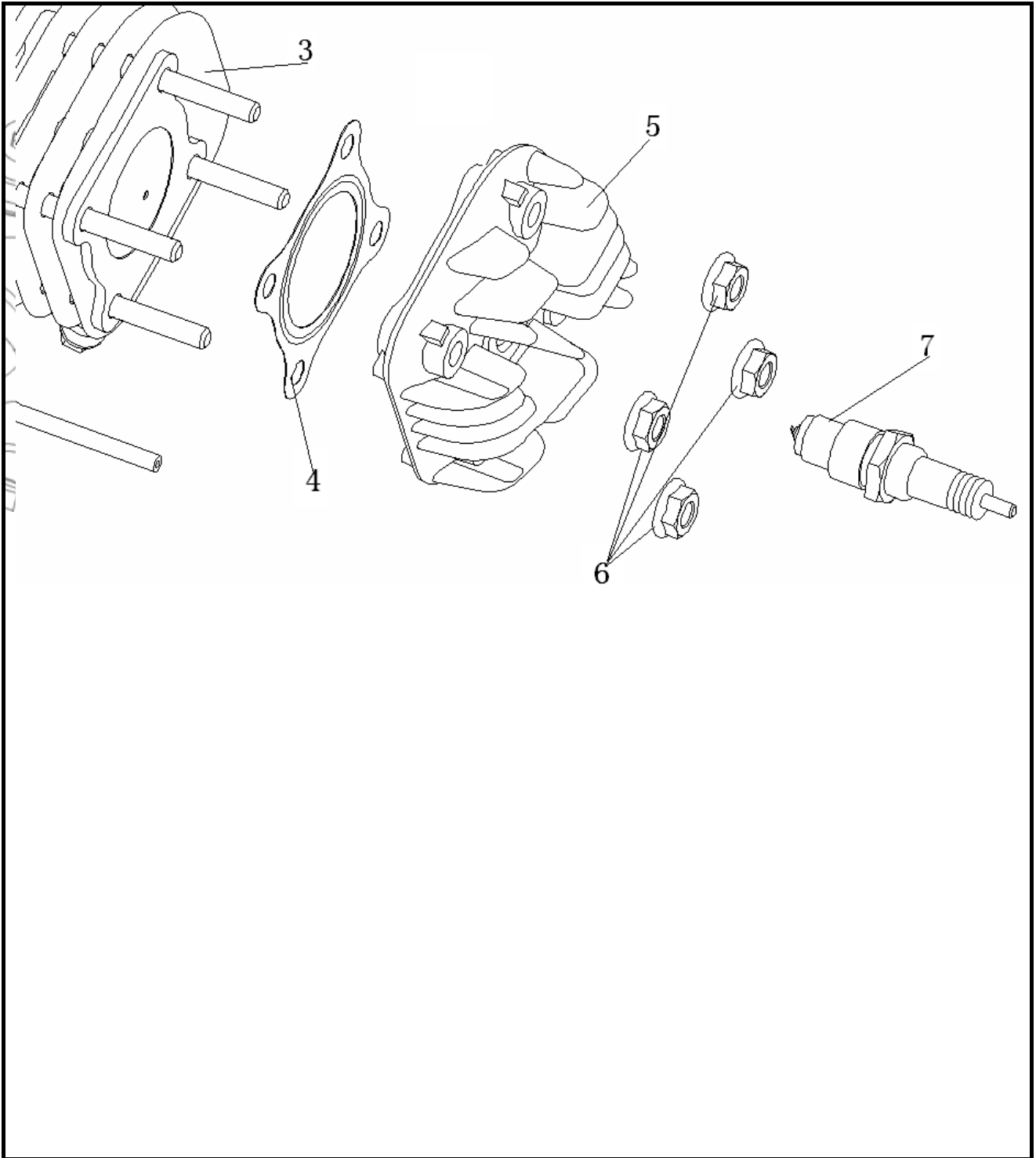

1. Piston 2. Piston pin. 3. Cylinder block. 4. Cylinder gasket. 5. Cylinder head. 6. Nut. 7. Spark plug

### XIII. Air cylinder/piston

Preparation data-----13.1	Piston-----13.4
Fault diagnosis -----13.2	Installation of the piston-----13.5
Cylinder body -----13.3	

#### 13.1 Preparation data

##### Matters needing attention in operation

All parts should be cleaned before inspection and test and should be blow dry with high pressure air.

**Function of the cylinder body :** The cylinder body provides space for the compression, burning and expansion of air and plays a steering function to piston motion.  
It also transmits part of the heat in the air cylinder to the surrounding cooling media.

##### Function of piston :

Bearing the pressure caused by burning of combustible mixture gas and pass the pressure to the connecting rod, driving the rotation of the crankshaft.

Shaping a combustion chamber with the cylinder cover and others.

Timingly press the fresh mixed gas from the crankcase into the cylinder and timely exhaust waste gas out of the cylinder after combustion.

##### Preparation standard

Unit : mm

Item		Standard value	Allowable limi
Air cylinder	internal diameter	39.995-40.015	40.05
	bend	-	0.05
	cylindricity	0.006	0.05
	flatness	0.03	0.05

	roundness		-	0.05
Piston Piston ring	clearance between the piston ring and ring groove	Top ring	0.015 - 0.05	0.09
		Second ring	0.015 - 0.05	0.09
	Joint face clearance	Top ring	0.1-0.25	0.5
		Second ring	0.1-0.25	0.5
	Piston outer diameter		39.97-39.99	39.9
	Clearance of cylinder and piston		0.005-0.015	0.1
	Piston pin hole inner diameter		12.002-12.008	12.04
Outer diameter of piston pin			11.994-12	11.96
Clearance between piston pin hole and piston pin.			0.002-0.014	0.02
Small end inner diameter of the connecting rod.			14.016-14.034	14.06

## 13.2 Fault diagnosis

### Low compression pressure

The piston is worn out , burnt out or broken.

The air and cylinder piston is worn out or damaged.

The gasket is damaged; there is air leakage between the crankcase and the gas.

### Compression pressure is too high

Carbon deposit in the combustion chamber is in overabundance.

### White fume in vent pipe

The piston spring is worn down or damaged.

The piston and air cylinder is worn out or damaged.

### Piston noises

·The air cylinder, piston and piston ring is worn out.

·The piston pin hole and piston pin are worn out.

## 13.3 Cylinder body

### 13.3.1 Disassembly of air cylinder body

Remove the air cylinder body, after dismantle the air cylinder cover.

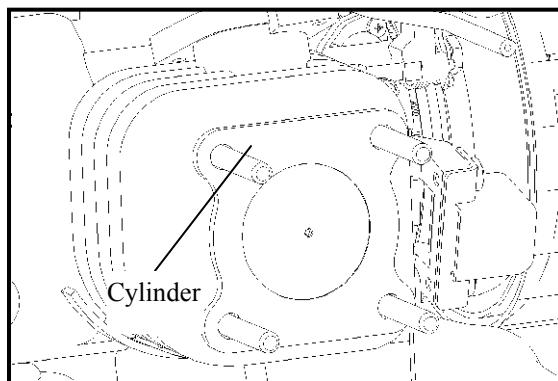

气缸体

### 13.3.2 Inspection of air cylinder body

Inspect the wear and tear of the cylinder inner wall.  
 Severe wear and replace it.  
 Inspect the cylinder face planeness of the cylinder block.

**Allowable limit : 0.05**

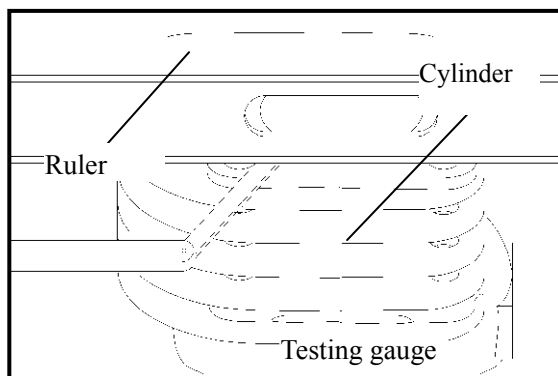

气缸体

直口

气缸盖

## 13.4 Piston

### 13.4.1 Disassembly

Disassemble the retaining ring for piston pin.

**\*Attention:** When disassembling , do not drop the retaining ring into the crankcase.

Withdraw the piston pin and unload the piston.

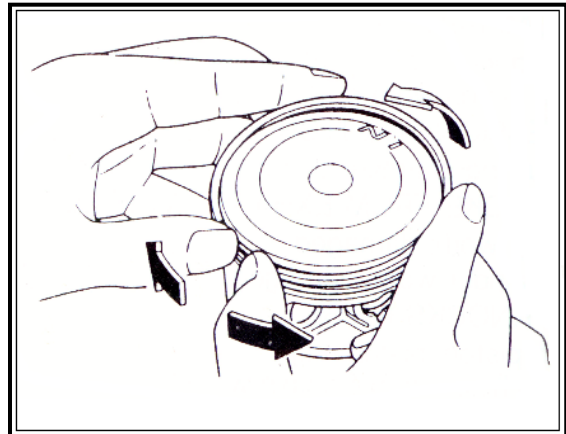
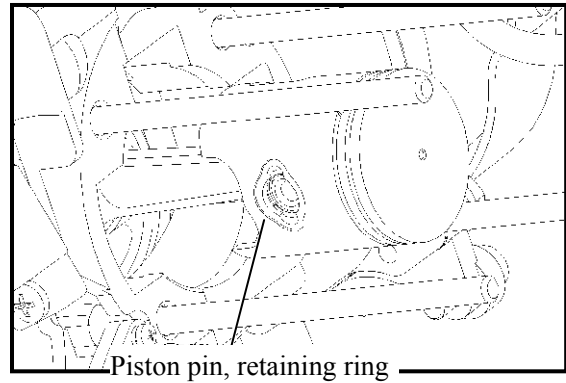

Inspect the piston, piston pin and piston ring.

Unload the piston ring.

**\*Attention:** Do not break or damage the piston ring.

Clean away the carbon deposit in the piston ring groove.

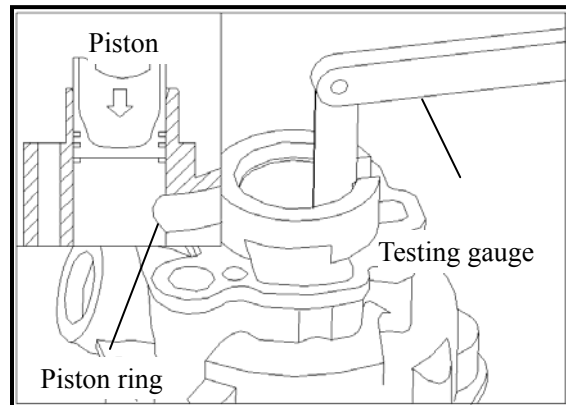

Unload the piston ring and install each piston ring at the bottom of the cylinder.

**\*Attention:** Press the piston ring into the air cylinder with the piston crown.

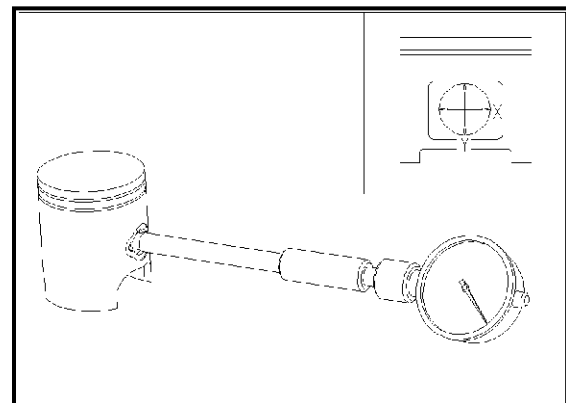

Measure the interface clearance of the piston ring.

**Allowable limit : 0.5mm.**

ଅନୁମତି ସୀମା

Measure the bore diameter of the piston pin hole.

**Allowable limit : 12.04mm.**

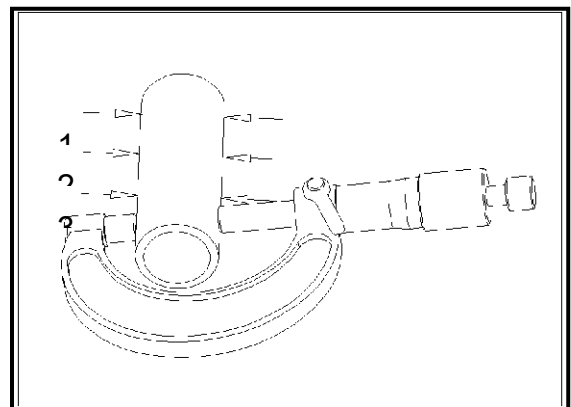

Measure the outer diameter of the piston pin.

**Allowable limit : 11.96mm.**

Clearance of piston pin hole and piston pin.

**Allowable limit : 0.02mm.**

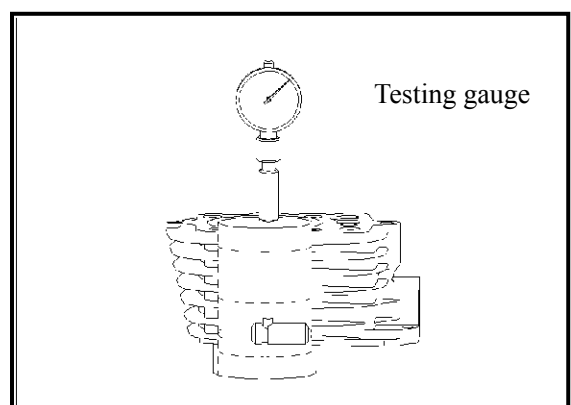
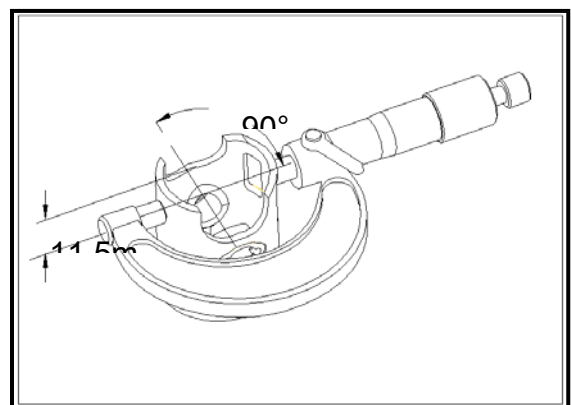

Measure the outer diameter of the piston.

**\*Attention:** The measuring position and the piston pin form an angle of 90 degree, some 11.5mm below the skirt of piston.

**Allowable limit : 39.9mm.**

Inspect the abrasion and wear of the cylinder inner wall.

**\*Attention:** Measure the bore diameter of the cylinder at the upper, middle and lower part when keeping an angle of 90 degree from the piston pin.

**Allowable limit : 40.05mm.**

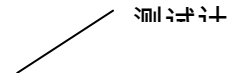

Measure the clearance of the cylinder and piston and take the maximal value as final one.

**Allowable limit : 0.1mm.**





Measure the roundness of inner wall ( bore diameter difference between X and Y direction ) .

**Allowable limit : 0.05mm.**

Measure the cylindricity of inner wall ( bore diameter difference at the upper , middle and lower part in X or Y direction ) .

**Allowable limit : 0.05mm.**

Measure the bore diameter of connecting rod small end.

**Allowable limit : 14.06mm.**

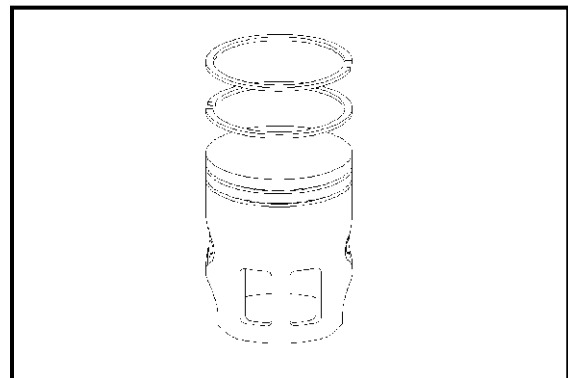
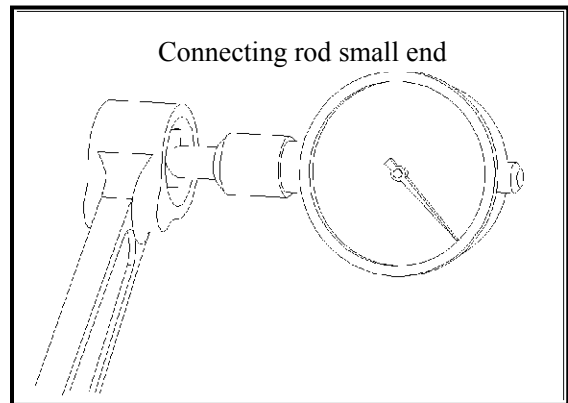
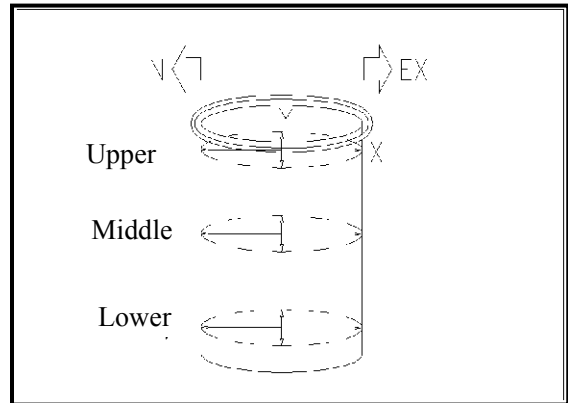

### 13.4.2 Installation of piston

Install the guide pin.

Paint the engine oil on each piston ring and piston. Install the piston in the right place with the mark of piston ring upward.

**\*Attention:**

The piston should not be scratched and the piston ring should not be broken.

After installed, the piston ring can rotate freely in the slot of the piston ring.

Scrape the adhesive gasket off the crankcase.

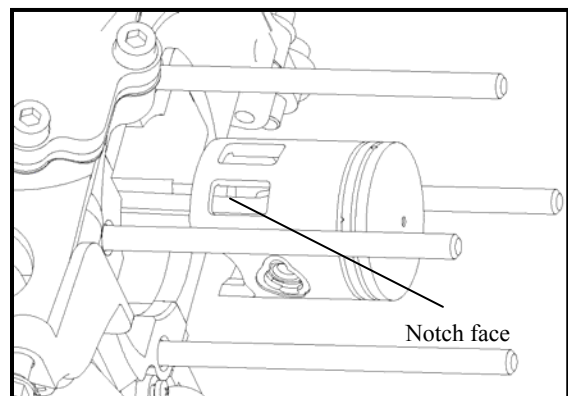

**\*Attention:**

No foreign objects should fall into the crankcase.

Install the piston, piston ring and retaining ring.

**\*Attention:**

Install the notch face of the piston skirt towards air intake duct.

## **13.5 Installation of piston**

Install the guide pin.

Paint the engine oil on each piston ring and piston.

Install the piston in the right place.

**\*Attention:**

The piston ring should not be broken.

## Drive disk/Clutch/Driven Wheel

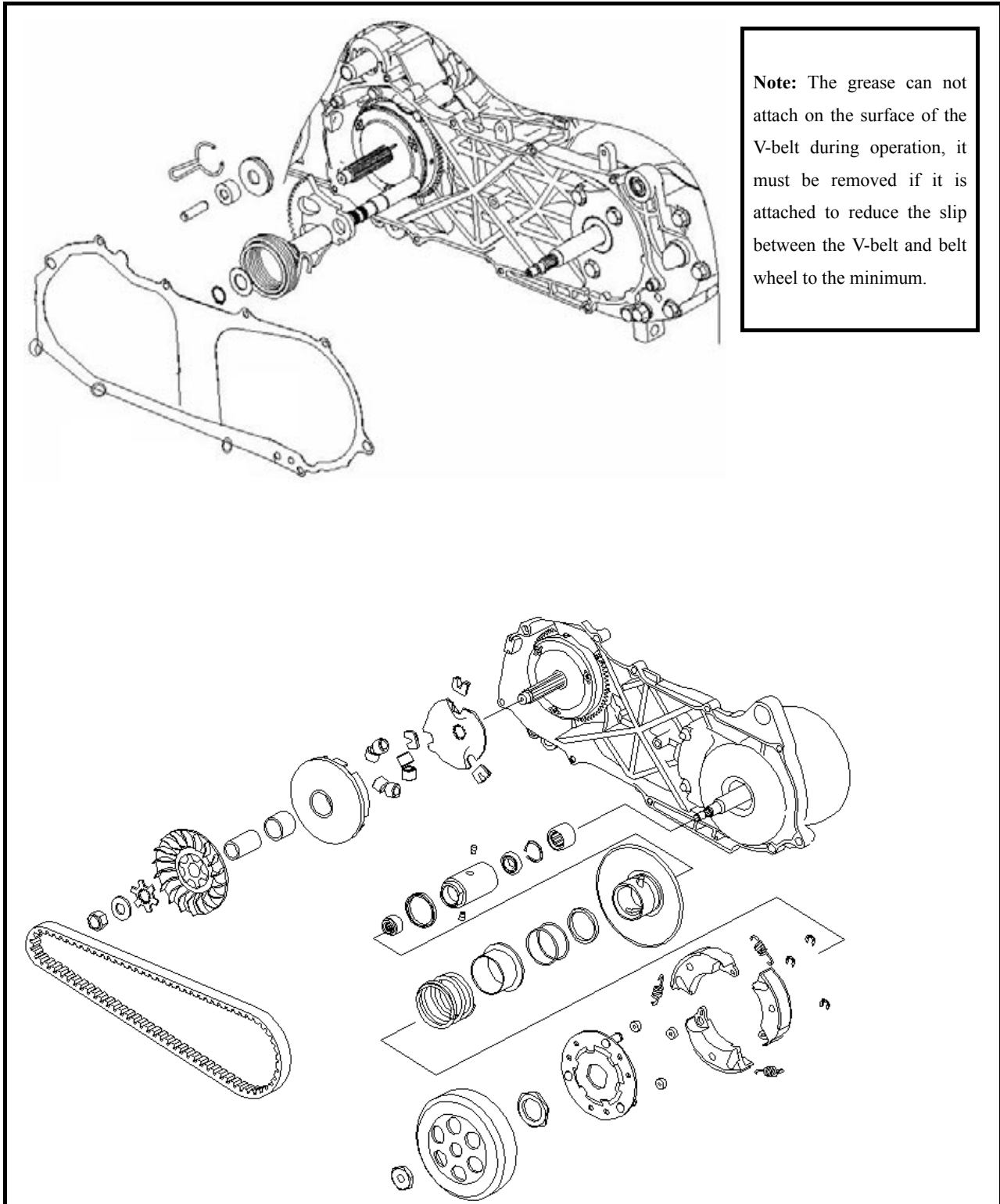

## Foot start mechanism

**Note:** The grease can not attach on the surface of the V-belt during operation, it must be removed if it is attached to reduce the slip between the V-belt and belt wheel to the minimum.

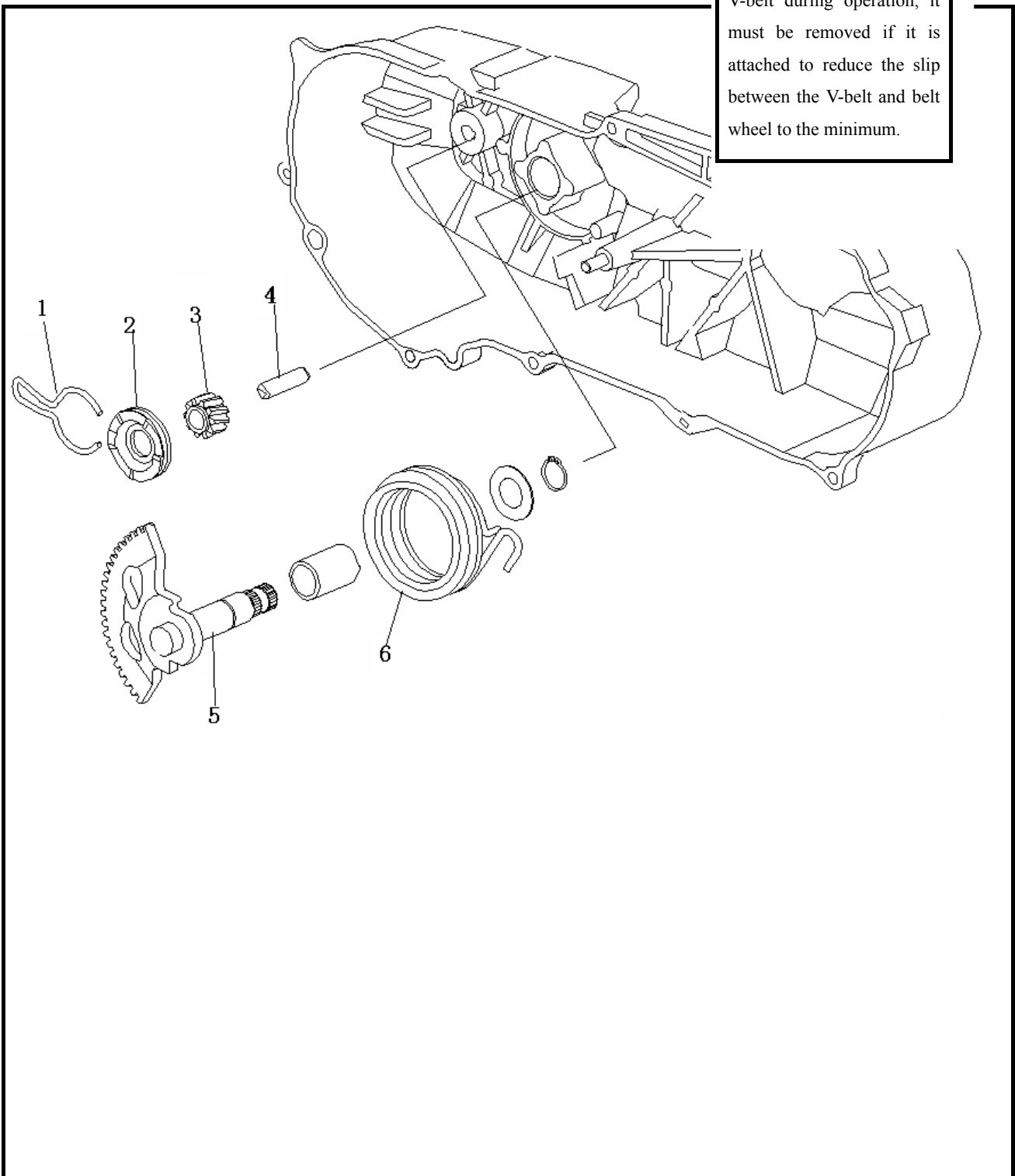

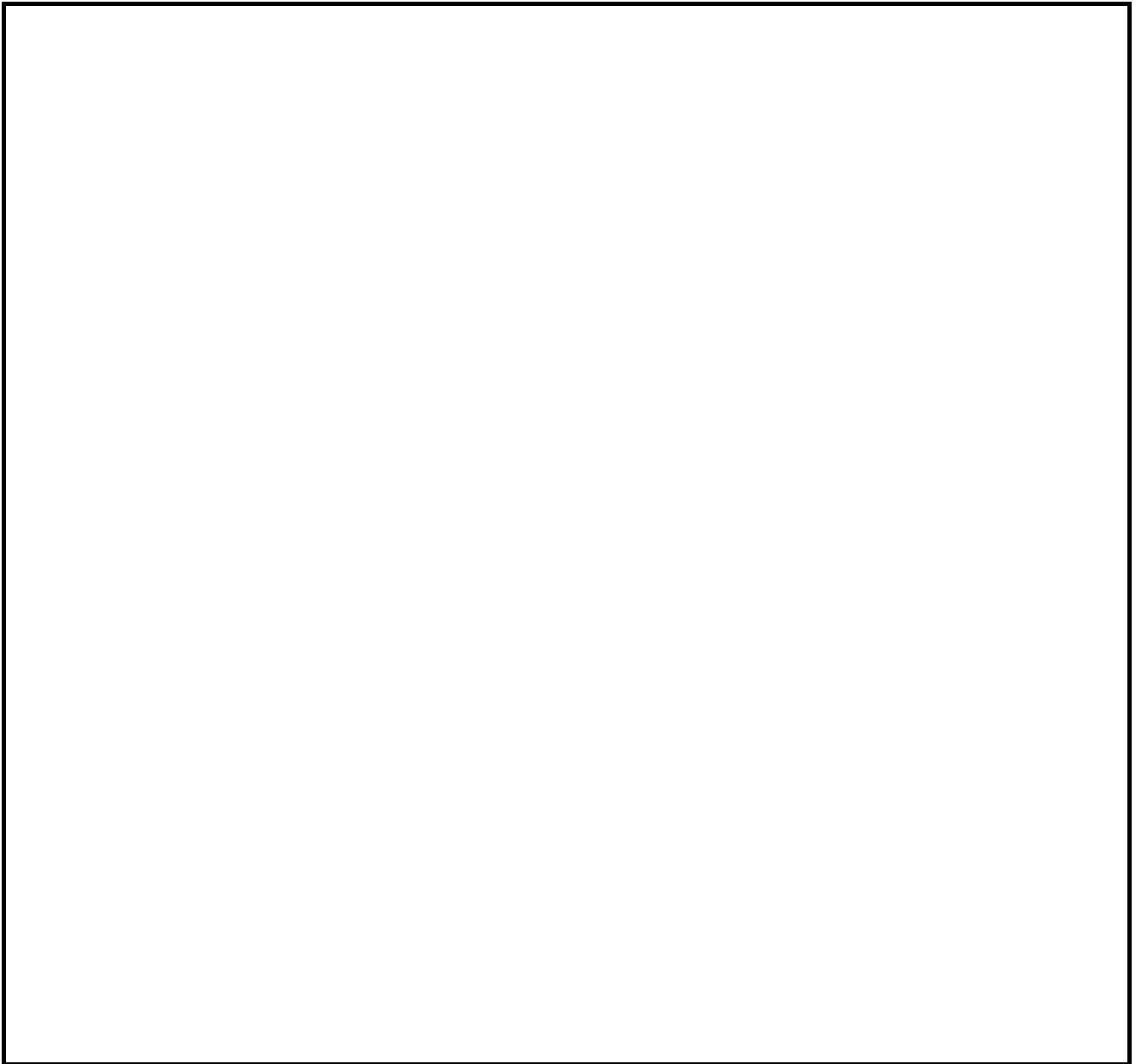

1. Snap ring. 2. Start claw. 3. Idle gear. 4. Idle gear shaft. 5. Start shaft component. 6. Foot start shaft spring.

## XIV. Drive disk/Clutch/Driven Wheel / Foot start mechanism

Preparation data -----14.1	Clutch/Driven Wheel -----14.5
Fault diagnosis-----14.2	Disassemble the clutch and the driven wheel -14.6
Left crankcase cover --14.3	Installation-----14.7
Drive disk -----14.4	Foot start mechanism -----14.8

### 14.1 Preparation data

#### Matters needing attention in operation

In the operation, there should be no grease on the surface of the triangle belt. Otherwise remove it to reduce the skidding between the triangle belt and belt wheel to the lowest.

**Function:** the drive disk, clutch and the driven wheel compose the steeples speeder. The torque between the dive disk and the driven wheel is transmitted through the triangle belt.

#### Preparation reference

Unit : mm

Item	Standard value	Allowable limit
the right half of the internal diameter of the drive wheel	25.989-26.052	26.06
the external diameter of sliding sleeve	25.96-25.974	25.94
width of the triangle belt	17	16
thickness of the friction plate of clutch	1.8	1.5
the internal diameter of outer sleeve of clutch	118-118.3	118.5
the free length of clutch-pressing spring	68-70	68
the external diameter of right-half shaft sleeve of the driven wheel	32.95-32.975	32.94
the external diameter of right-half sliding sleeve of the driven wheel	33-33.025	33.06
the external diameter of the rolling ball	14.92-15.08	14.4

### 14.2 Fault diagnosis

The motor can not move after the engine is started

The horsepower is not sufficient

There is shaking in the movement

The triangle belt is worn out

The triangle belt is worn out The friction-plate spring of clutch is broken out.

The driven wheel is worn out

The clutch spring is deformed

The clutch friction plate is damaged or worn out.

The ball bearing is worn out

The clutch spring is broke

The surface of the driving pulley is stained.

### 14.3 Left crankcase cover

#### Disassembly

Dismantle the fixing bolt of the case cover and take down the gasket and the guide pin.

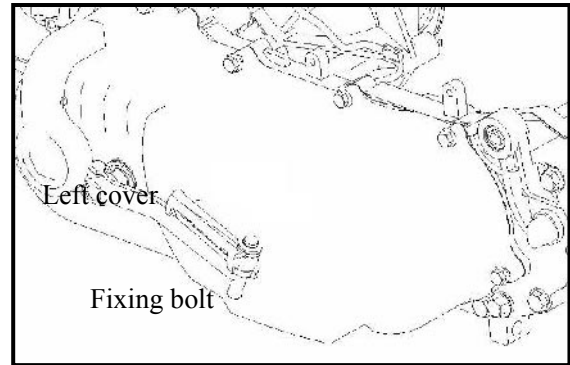

#### \*Attention:

When dismantling the fixing bolt, loosen and dismantle it in cross way.

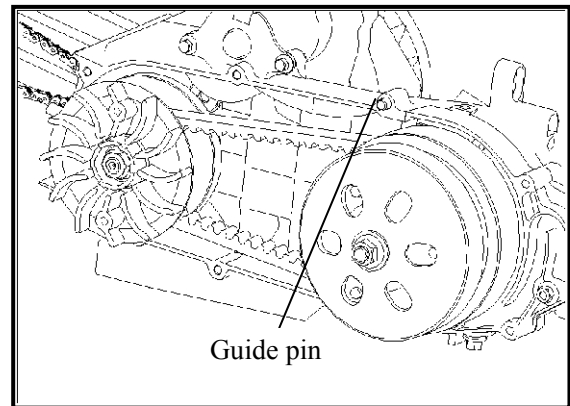

Take down the gasket and the guide pin.

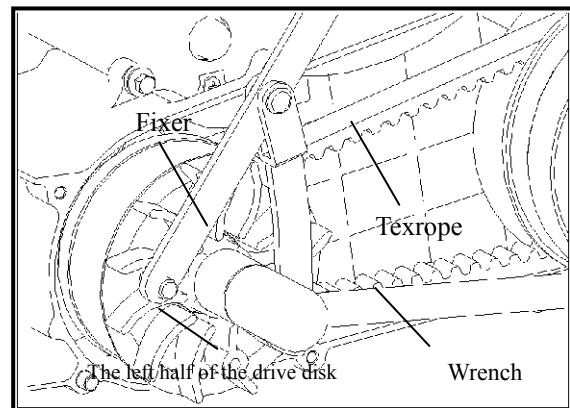

### 14.4 Drive disk

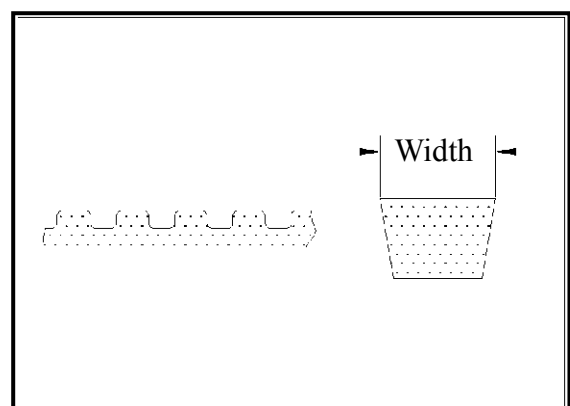



## 14.4.1 Disassembly

Dismantle the fixing nut of the drive disk and take down the left half of the drive disk.

Take down the triangle belt from the drive disk.

Check whether the triangle belt is chapped and whether the rubber and cotton yarn fall off or are abnormally worn out.

Measure the width of the triangle belt.

**Allowable limit : 16mm.**

**\*Attention:**

When replacing, select the original parts.

Dismantle the right-half components of the drive wheel.

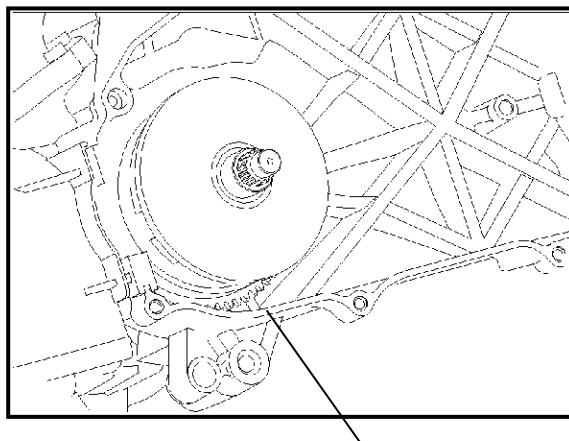

Right-half components  
of the drive wheel

#### 14.4.2 Decompose the right-half components of the drive wheel.

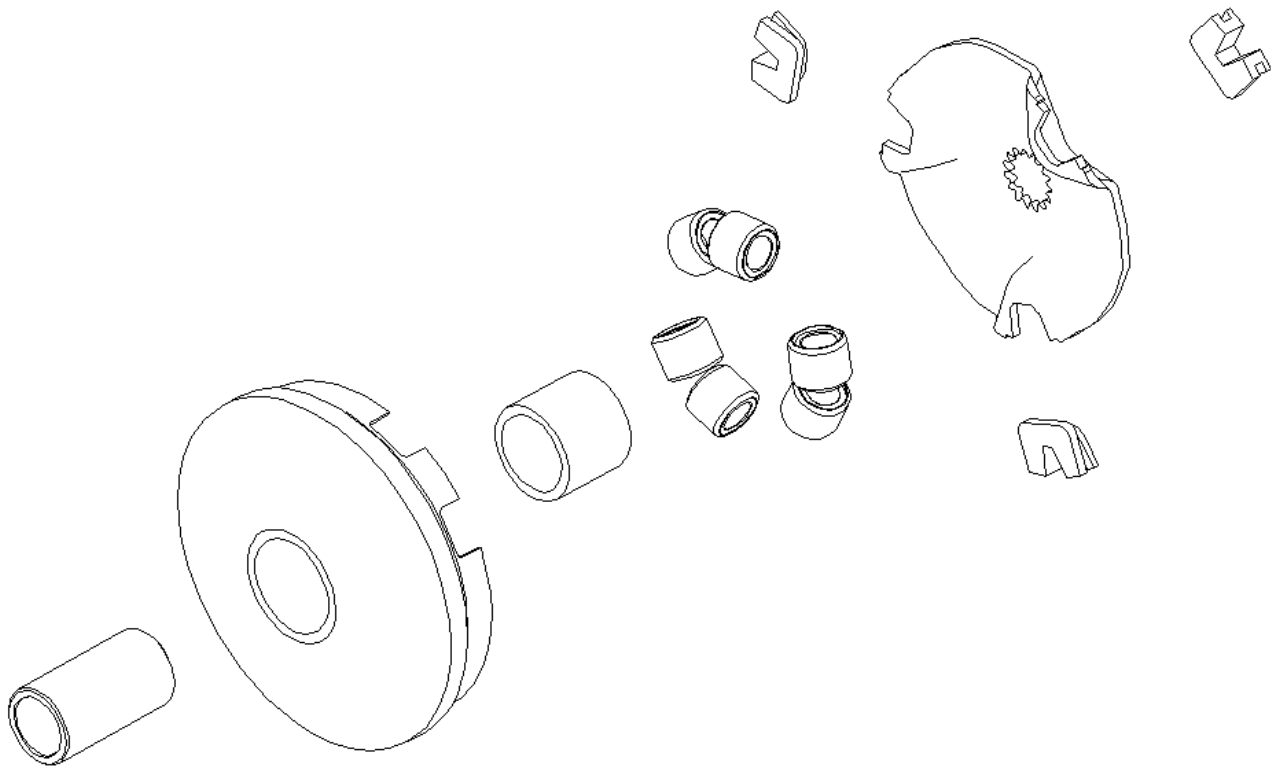

Check the abrasion of the ball bearing.  
Measure the external diameter of the ball bearing.

**Allowable limit : 14.4mm.**

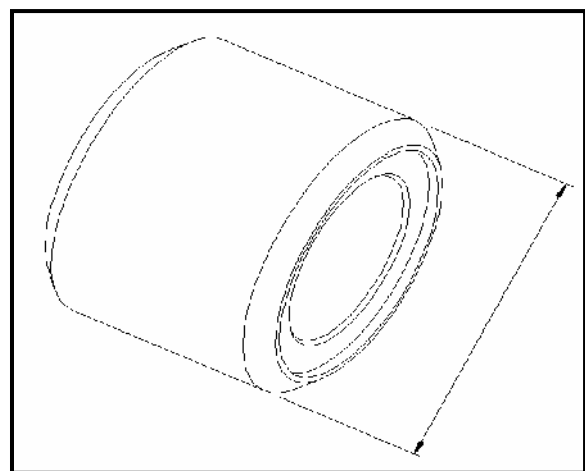

Measure the right-half internal diameter of the driven wheel.

**Allowable limit : 26.06mm.**

Measure the external diameter of the sliding sleeve.

**Allowable limit : 25.94mm.**

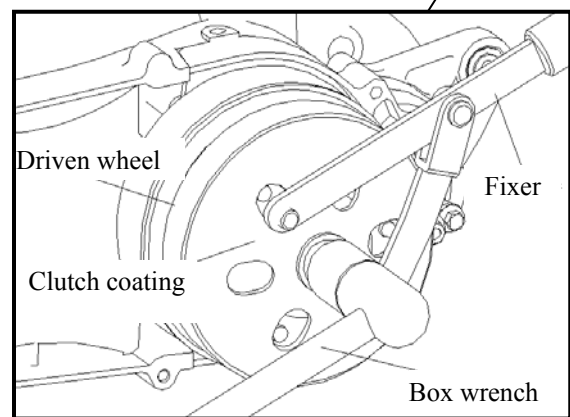
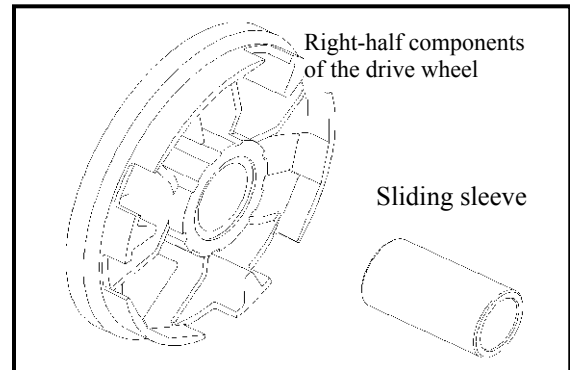

## 14.5 Clutch/driven wheel

### 14.5.1 Disassembly

Fix the outer part of clutch with the fixing tool and dismantle the fixing nut.

Take down the outer part of clutch, clutch/driven wheel.

### 14.5.2 Decomposing the clutch

Dismantle the check ring and decompose the clutch.

**\*Attention:**

When decomposing, there should be no grease adhesive to the friction plate of clutch.

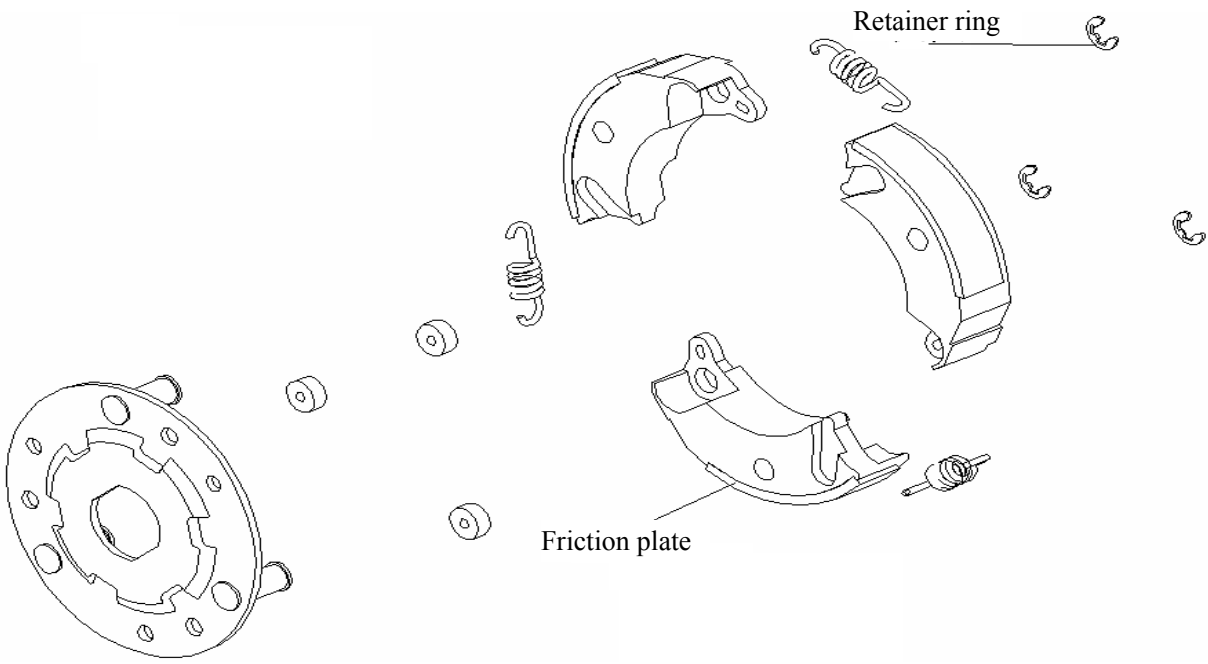

Check the abrasion of the outer part of clutch.  
Measure the internal diameter of the outer part of clutch.

**Allowable limit : 118.5mm.**

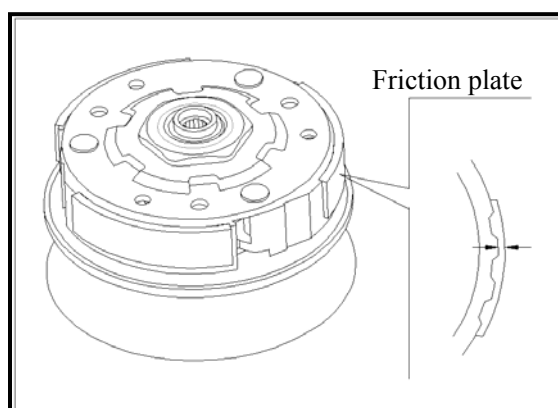
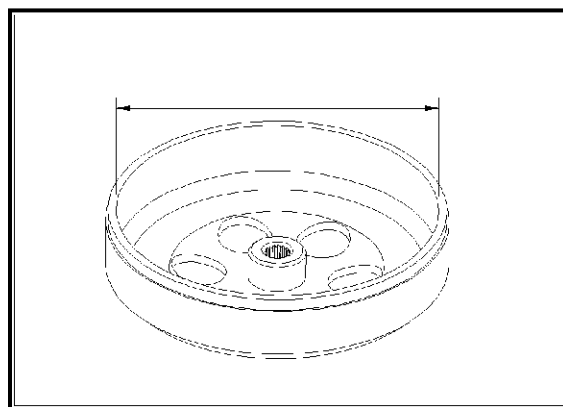

Check the abrasion of the friction plate of clutch.  
Measure the thickness of the friction plate.

**Allowable limit : 1.5mm.**

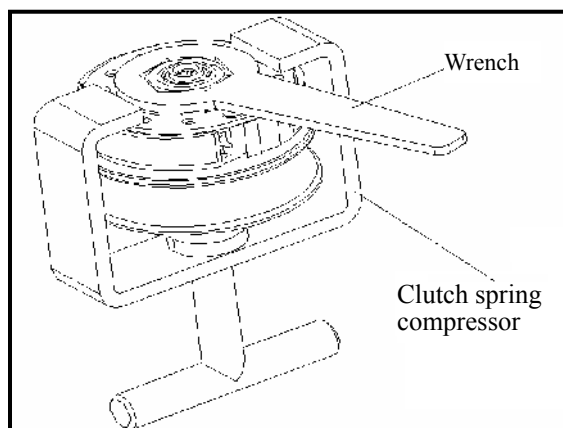

## 14.6 Disassemble the clutch and the driven wheel

When dismantling the clutch-pressing spring, use the clutch spring compressor in the operation.

**\*Attention:**

The spring compressor must be used in dismantling to prevent damaging the spring.

Fix the spring compressor and dismantle the fixing nut of clutch.

Loosen the compressor and decompose the clutch and driven wheel.

Take down the protective jacket of the spring.

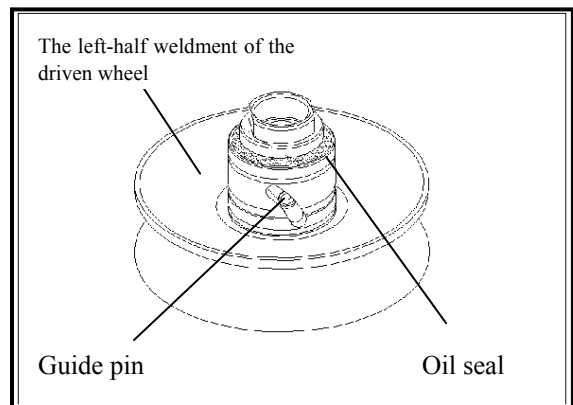
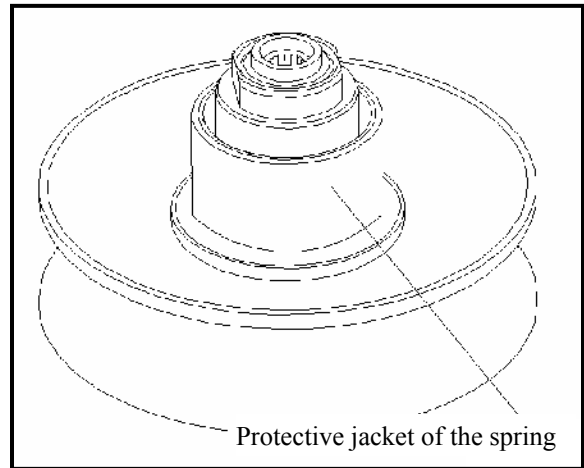

Dismantle the guide pin.  
Take down the left-half weldment of the driven wheel.  
Dismantle the oil seal from the left-half part of the driven wheel.

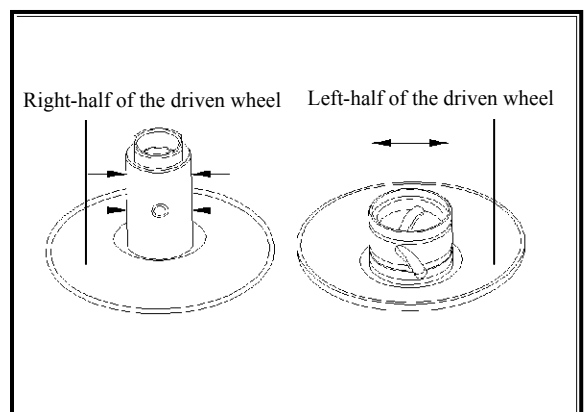
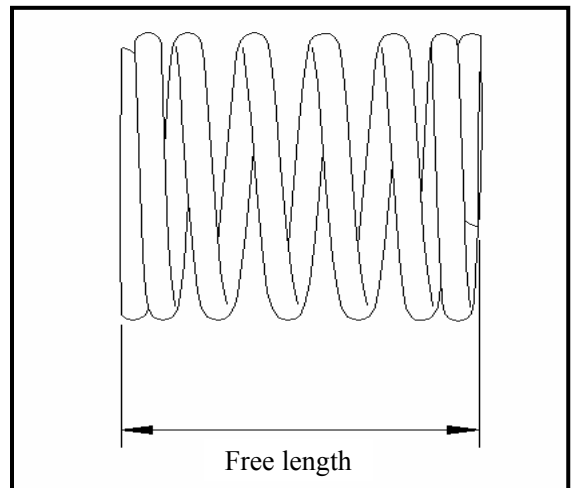

Check the free length of the clutch spring.

**Allowable limit : 68mm.**

Check the abrasion of the driven wheel.  
Measure the external diameter of the right-half shaft sleeve of the driven wheel.

**Allowable limit : 32.94mm.**

Measure the internal diameter of the left-half sliding sleeve of the driven wheel.

**Allowable limit : 33.06mm.**

### 14.6.1 Replacement of the right-half bearing of driven wheel

Take down the needle bearing from the right-half driven wheel.  
Dismantle the elastic check ring and the outer rolling bearing.

**\*Attention:**  
The dismantled bearing can not be used again.

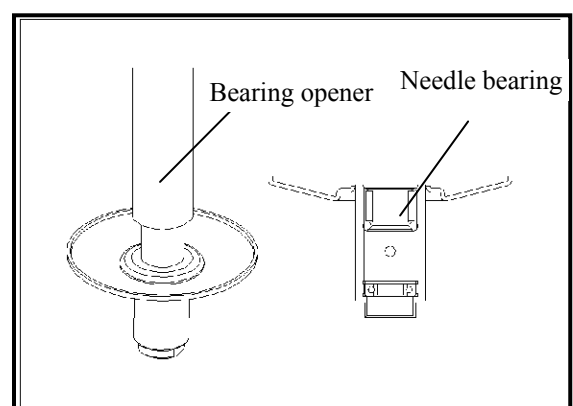
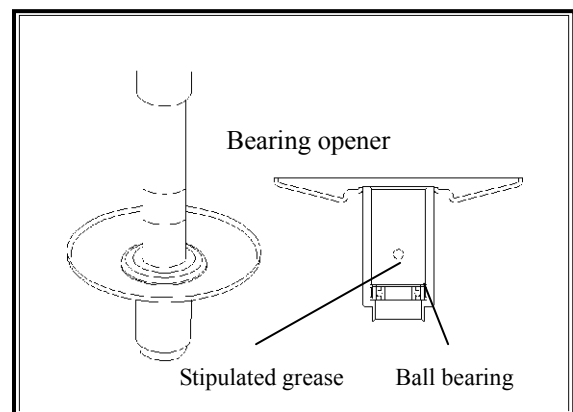
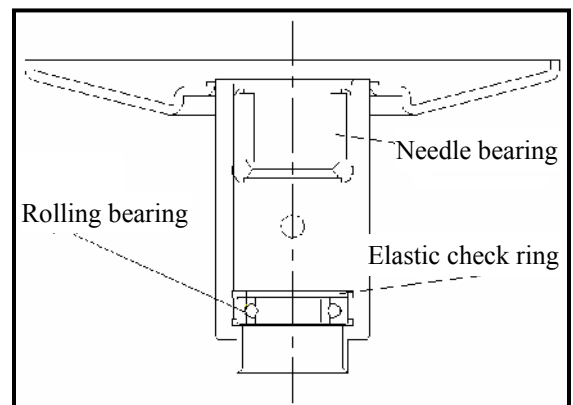



Paint grease on the outer rolling bearing and put it into the shaft sleeve.

**\*Attention:**

Compress the outer rolling bearing into the shaft sleeve with the marked side outward. Then fill the 8-9g grease in the whole shaft cavity.

Assemble the elastic check ring.

Install the needle bearing.

Use the tools in the picture to compress the needle bearing.

## 14.6.2 Combination of clutch and driven wheel

Clean the grease on the driven wheel surface.  
 Install the oil seal in the left-half sliding sleeve of the driven wheel.  
 Paint grease on the O-typed ring and install it on the left-half sliding sleeve of the driven wheel.

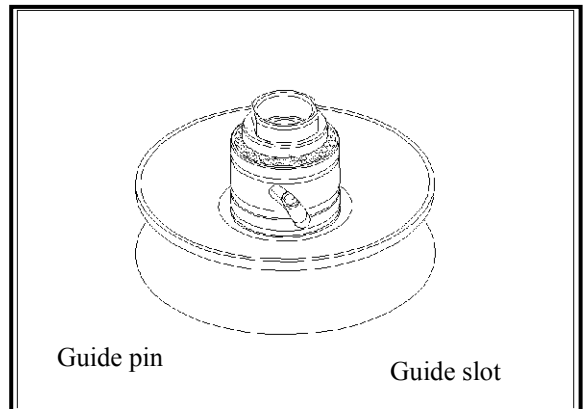
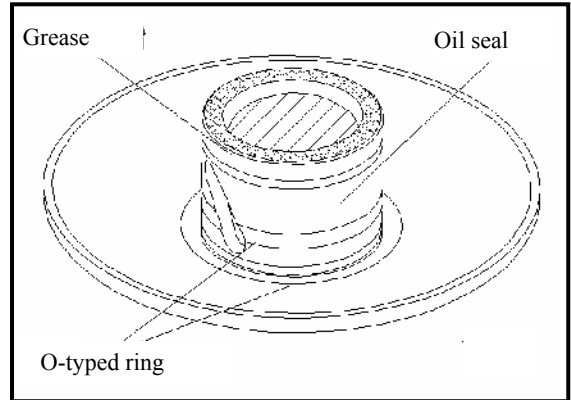

Combine the left-half and right-half parts of the drive wheel.  
 Paint grease on the guide pin install in the guide slot.

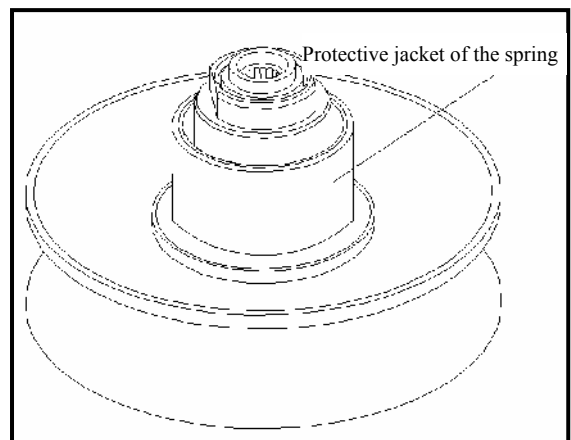

Install the protective jacket of the spring.  
 Wipe and clean the leakage grease.

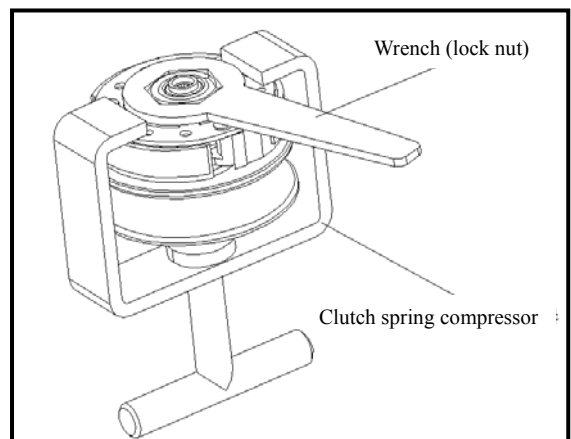

Install the clutch-pressing spring and clutch on the driven wheel.

Use clutch spring to compress and compose. After compression, install the locking nut.

**\*Attention:**

the spring should be compressed properly. Otherwise, the spring will be damaged.

## 14.7 Installation

The order of assembling the driven disk, clutch and driven wheel is opposite to that of disassembly.

## 14.8 Foot start mechanism

### Disassembly /Check

Dismount left crankcase cover.

Loosen screw, take out plate.

Take off start claw component.

Take off start shaft component.

Inspect the wear condition of the start shaft

Inspect the wear condition of the start shaft sleeve,

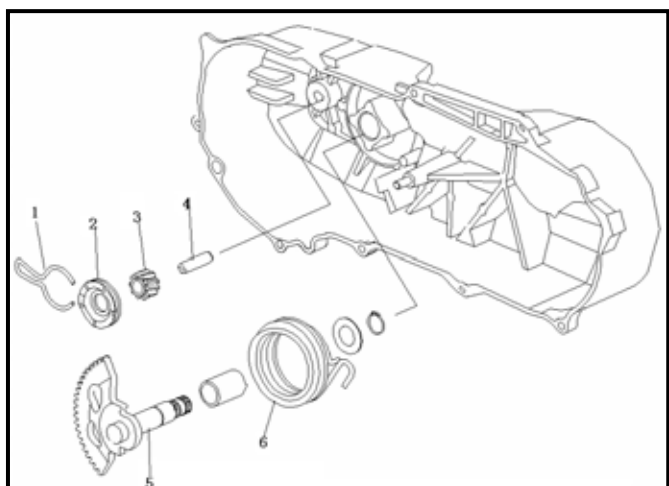

idle wheel shaft force position.

Inspect the wear condition of the idle wheel.

Measure the clamping force of the snip ring.

**General standard value: 8-12N.**

**Note: 1. Snap ring. 2. Start claw. 3. Idle gear. 4. Idle gear shaft. 5. Start shaft component. 6. Foot start shaft spring.**

## Decelerator

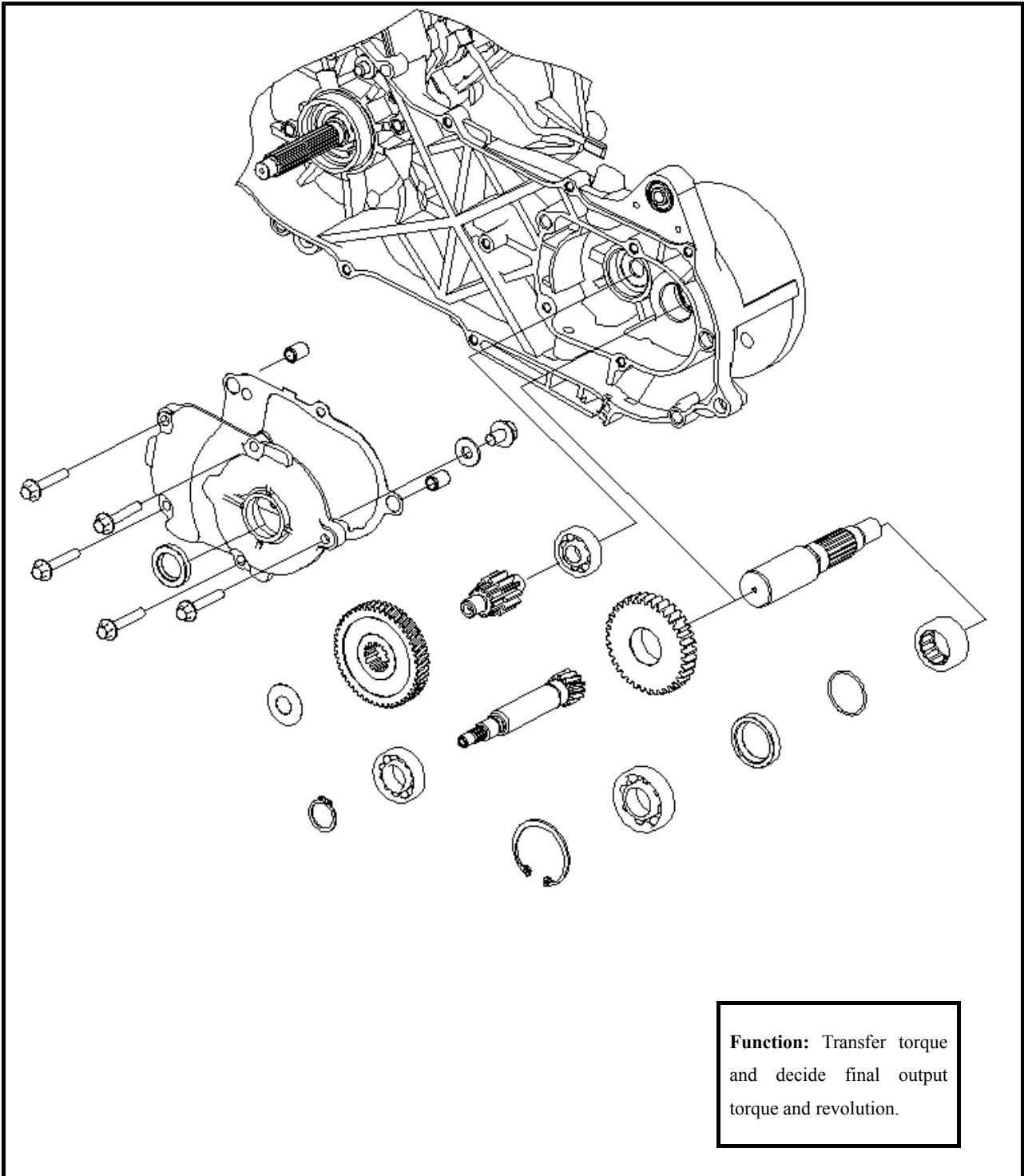

## **XV. Decelerator**

Preparation data -----	15.1
Fault diagnosis-----	15.2
Gear case -----	15.3
Installation-----	15.4

### **15.1 Preparation data**

**Function:** convey the torque and determine the torque and rev of the final output.

### **15.2 Fault diagnosis**

**The motor can not move when the engine is started.**

The drive gear is broken.

The drive gear is burnt out.

**The gear oil is leaked.**

The gear oil is too much.

The oil seal is damaged.

### **15.3 Gear Case**

#### **15.3.1 Disassembly**

Dismount oil drain nut, drain out oil from the gearbox.

Loosen the bolt and take down the gear case cover.

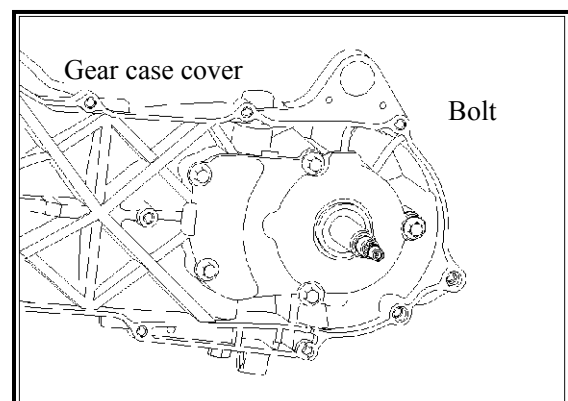



Take down the gasket and the guide pin.  
Take off the clutch main shaft, output shaft gear.  
Take off the middle shaft, middle shaft gear.

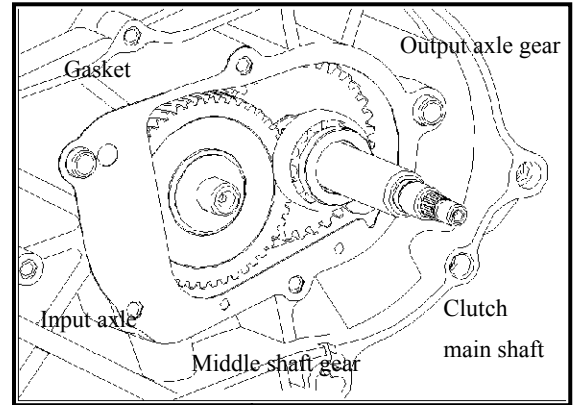

### 15.3.2 Output gearbox cover inspection

Clutch main shaft, gear, bearing wear, damage inspection.  
Gearbox cover bearings exchange.  
The clutch main shaft must be pressed during the clutch main shaft bearings exchange.  
Take off from the gearbox cover.

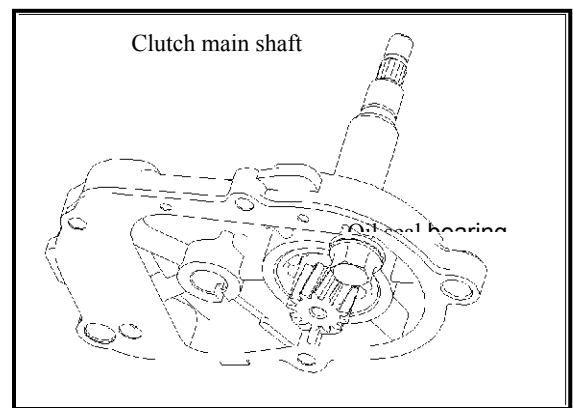

**\*Attention:**

The bearing which is pushed out can not be used and should be replaced.  
The disassembly of bearings and oil seal should use special tools.

Dismantle the oil seal on the gear case and push out the bearing.

**\*Attention:**

The bearing which is pushed out can not be used and should be replaced.  
The disassembly of bearings and oil seal should use special tools.

## 15.4 Installation

The order of assembly is opposite to that of disassembly.



**\*Attention:**

The assembly of bearings and oil seal should use special tools to prevent damage.

## **Crankcase**

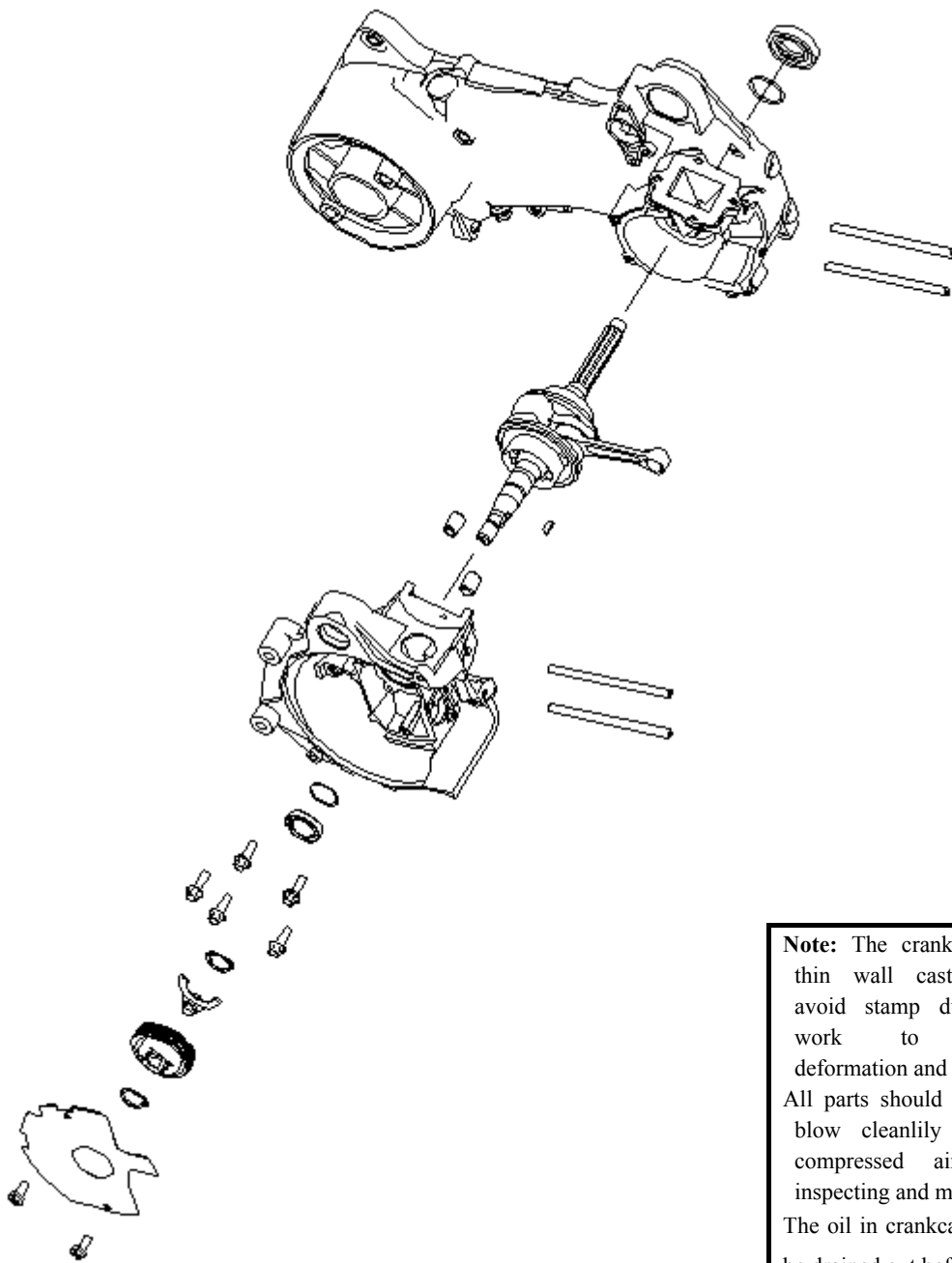

**Note:** The crankcase is a thin wall casting part, avoid stamp during the work to prevent deformation and breakage. All parts should clean and blow cleanlily by high compressed air before inspecting and measuring. The oil in crankcase should be drained out before work.

## XVI. Crankcase

Preparation data -----	16.1
Fault diagnosis-----	16.2
Crankcase-----	16.3
Installation -----	16.4

### 16.1 Preparation data

#### Matters needing attention in operation

Since the crankcase is a thin-section casting, please avoid impact on it during operation in case there is any distortion or rupture.

All parts should be cleaned before inspection and test and should be blow dry with high pressure air.

Before operation, discharge the lubricating oil in the crankcase.

**Function of the crankcase :** The crankcase is the bearing part of the engine. Its primary function is supporting the crankshaft, clutch, gearbox, cylinder body as well as the cylinder cover and bearing bursting impact of combustion and movement inertia force of crankshaft connecting rod system and constituting some closed ( oil, air seal) space.

The crankcase has a hanging hole which links the engine and the frame with other parts by connecting with the hanging hole.

#### Preparation reference

Unit : mm

Item		Standard value	Allowable limit
Crankshaft	clearance of connecting rod big end in right and left direction	0.25-0.40	0.55
	Radial clearance of the big end of connecting rod	0.015-0.025	0.05

#### Tools

Multiple use fixer

Driver's perch

Guide rod

Clutch spring compressors

Box spanner

Bearing driver

## 16.2 Fault diagnosis

Strange noises in crankcase

Parts shattered or broken in crankcase

The bearings of crankshaft pin are loosened.

The crankshaft bearings are loosened.

Clutch depressed

## 16.3 Crankcase

### 16.3.1 Disassembly of crankcase

Loosen bolt, take off the start drive gear.

Take off the gear on the satellite wheel seat.

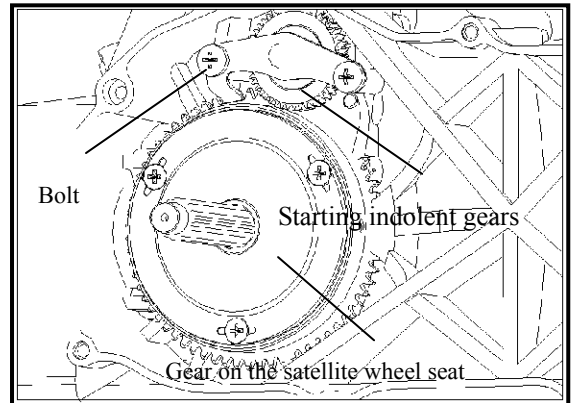

Dismount crankcase fixing bolts.

Dismount left, right crankcase.

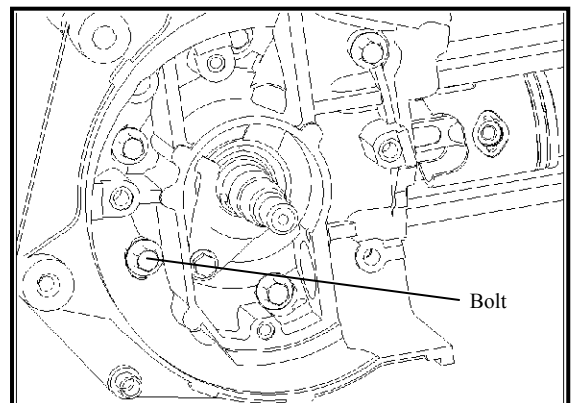

#### \*Attention:

Don't damage the gasket.

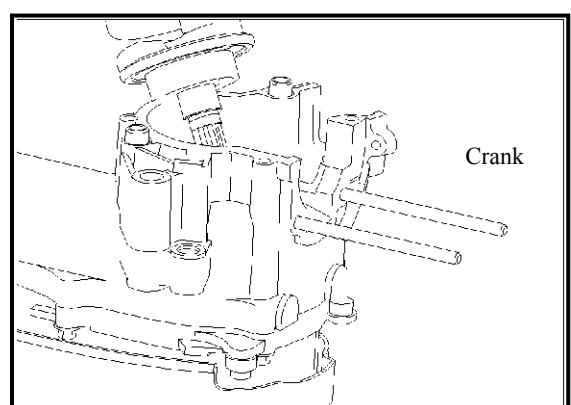
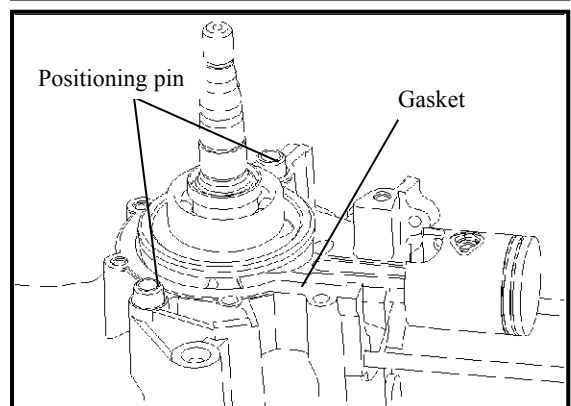

Take down the gasket and the guide pin.

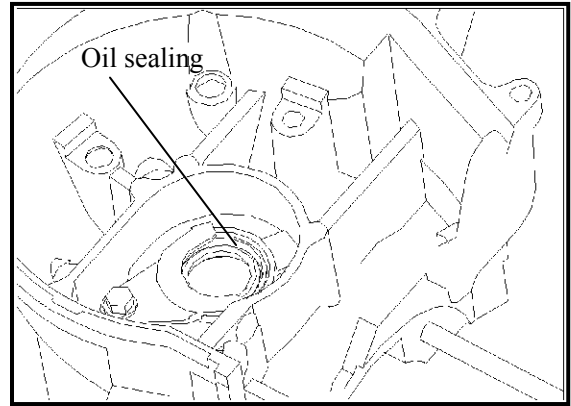

Take off the crankshaft from the crankcase.  
Scrape off the gasket on the crankcase joint face.

**\*Attention:**

Don't damage the crankcase joint face.

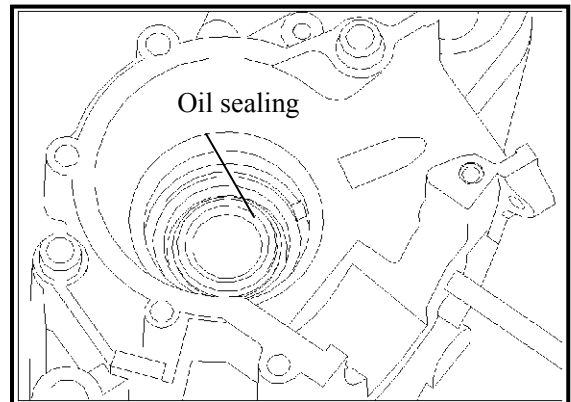

Dismount oil sealing from the left crankcase.

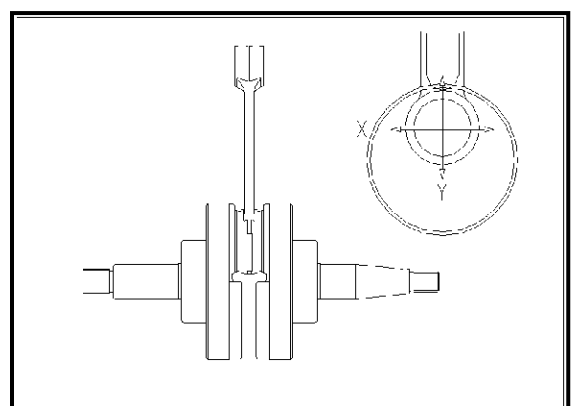
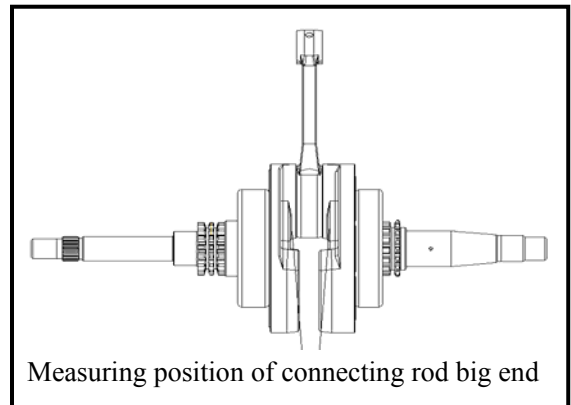

Dismount oil sealing from the right crankcase.

### **16.3.2 Inspection**

Clearance measurement of connecting rod big end in right and left direction

**Allowable limit : 0.6mm.**

Clearance measurement of connecting rod big end in X and Y direction

**Allowable limit : 0.05mm.**

Inspect whether there are strange noises or loosening in rotation of the crank shaft bearing.

If there is strange noises or loosening , replace the crankshaft set.

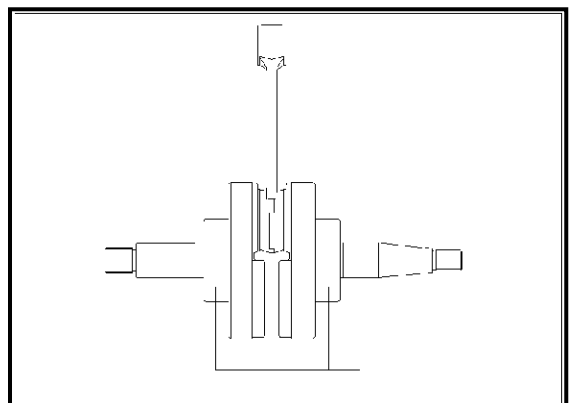

Crankcase bearing

**\*Attention:**

The dismantled oil seal can not be used again.

The dismantling of the oil seal should use special tools.

## **16.4 Installation**

The order of assembling crankcase is opposite to that of the disassembly.

**\*Attention:**

The installation of oil seal should use special tools in order to prevent the damage against the oil seal.



# Exhaust emission system inspection and maintenance

## Muffler

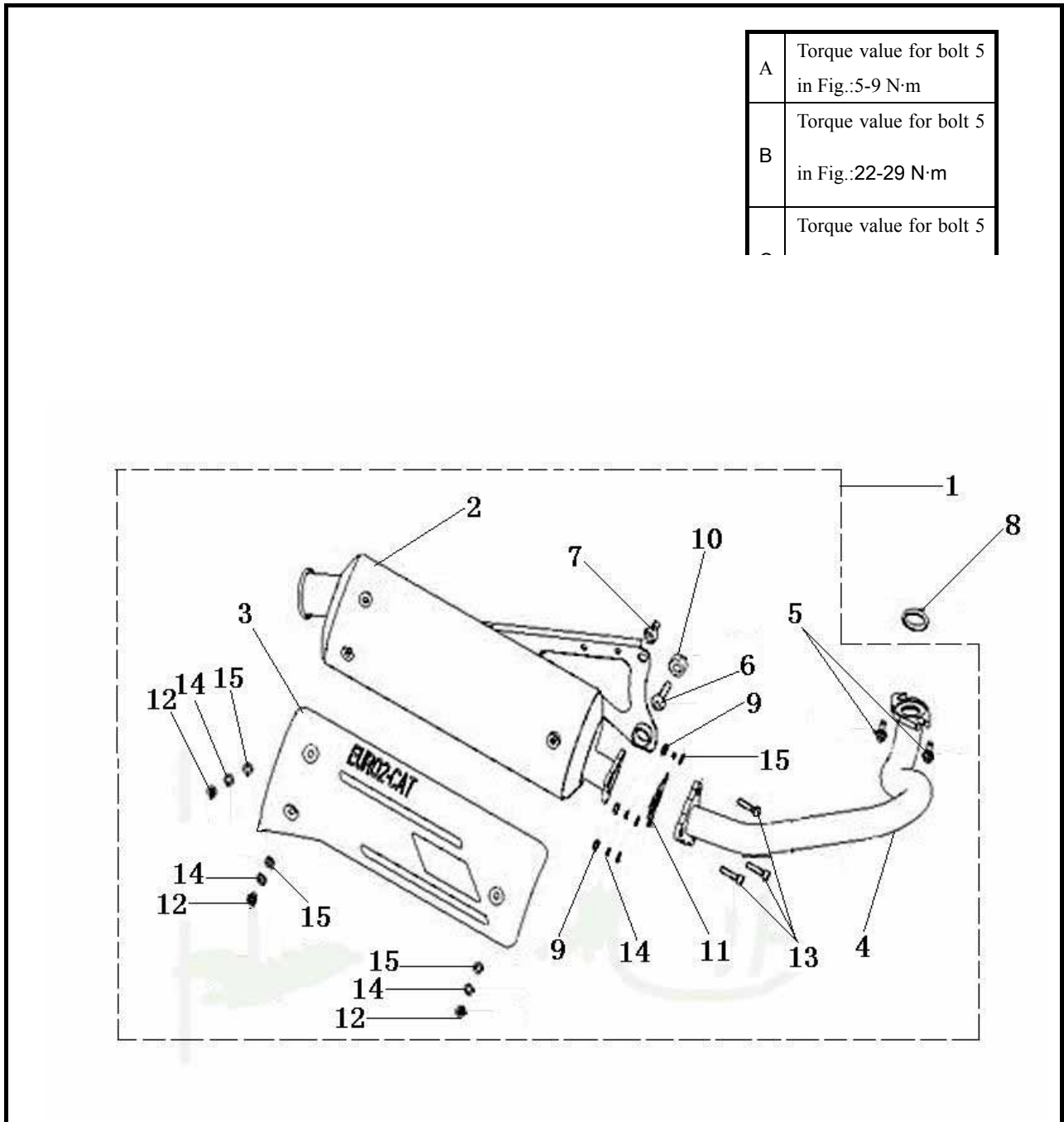

1. Silencer assembly. 2. Silencer body. 3. Silencer decoration cover. 4. Silencer front section. 5. Bolt M6×16. 6. Bolt M8×35. 7. Bolt M8×20. 8. Exhaust pipe gasket component. 9. Nut M6. 10. Silencer damping sleeve. 11.

Connecting flange sealing gasket. 12. Screw M6×10. 13. Screw M6×25. 14. Spring washer 6. 15. Washer 6.

## **XVII. Exhaust emission and control system**

Warranty of Exhaust emission and control system -----	17.1
Regular maintenance guideline/ensurance of emission standard -----	17.2
Mechanical function of the exhaust control system -----	17.3
Catalyst converter system -----	17.4
Countermeasures to idle speed emission exceeding specified value -----	17.5

### **17.1 Warranty of Exhaust emission and control system**

1. The exhaust emission and control system of this motorcycle conforms to European Union EC/97/24/5/I and the revised version of 2002/81/EC B stage. Our Company gives warranty if the user fully follows regular service and specified maintenance of the system in effective service life.

#### 2. Warranty scope

##### 1) Function warranty of exhaust emission and control system

We guarantee that within riding of 15 thousand km, regular or irregular exhaust inspection standards implemented by the government will be satisfied.

3. If the following conditions occur, this warranty clause is not applicable, but maintenance and service at a reasonable price will be provided to customers by our dealers or service departments at province or city level.

1) Regular maintenance is not performed in accordance with the specified time or service kilometers by our Company.

2) Those who do not have regular inspection , adjustment or service at our dealers or service centers or who fail to bring forward the maintenance records.

3) Overload or improper use

4) Reconstruction of the vehicle, disassembly of original binding parts or mounting other equipment at will

5) Used for racing or frequent riding on roads for non-motorized vehicles

6) Damage caused by typhoon, flood and other natural disasters, or damage and fault caused by negligence , traffic accidents , collision with foreign objects.

7) Long-term disuse without regular maintenance

8) Odometer damaged without immediate repair or factitious reconstruction, disuse and replacement

9) Please go to the check point for regular exhaust inspection every 3 months.

The new motorcycle produced by the Company has passed EC 97/24/9 standards implemented by the European Union after noise inspection.

## 17.2 Regular maintenance guideline

To prevent further environment pollution, the State requires all automotive vehicles by manufacturers should meet standards of air pollution emission. Our Company does its utmost to purify air and reduce air pollution besides ensuring that production conforms to standards.

Each of the motorcycles has passed strict inspection before delivered out of the company and meets standards of air pollution emission. But since customers differ in use of our products, we've established the following regular inspection table for exhaust emission to ensure normal emission. Please inspect, adjust or service the motorcycle at schedule time.

For special problems of use , please inquire the dealers or service centers of Qianjiang.

Related emission regulations are as follows :

Emission regulation	CO	HC+ NO <sub>x</sub>
Emission standard	≤1.0g/km	≤1.2g/km

□ If there is any change to the emission standard, take the up-to-date state regulation as final.

If the motorcycle is banned due to nonperformance of periodic inspection at dealers or service centers of Qianjiang, we do not shoulder any responsibilities. Please make necessary inspection at any time in order to maintain optimized vehicle conditions.

Note : □ Increase cleaning times of air filter if the motorcycle is used on sandstone roadways or in severely polluted environment, so that service life of the engine may be extended.

□ When the vehicle is driven at high speed or in frequent use with considerable service kilometers, its maintenance degree should be increased.

**Ensure the emission standards and pay attention to the following matters:**

- 1) Please use 92 or 95 unleaded gasoline only.
- 2) Please use machine oil of specified Standard only.
- 3) Please maintain the motorcycle according to stipulations in the regular maintenance table.
- 4) As to exhaust control system, random adjustment or replacement ( including use of spark plug, idle adjustment, ignition timing, carburetor adjustment ) is strictly forbidden .

5) Matters needing attention :

· The disorder of ignition, charge and fuel system will have great impact on the catalyst device, therefore, if you feel disorder of the engine, please go to designated dealers or service centers of our Company for inspection, adjustment or service.

· Please use 92 or 95 unleaded gasoline only, or else the catalyst device ( four-stroke system ) will be damaged.  
(Two-stroke system)

6) The exhaust control system of the product conforms to state regulations , so make sure to use parts from Qianjiang when replacing any part of the system. And the replacement should be carried out by the designated dealers or service centers.

## **17.3 Mechanical function of the exhaust control system**

### **Outline**

The countermeasure of exhaust gas is taking the four-stroke single-cylinder engine , carburetor mode as the reference and adopts Air induction device to maintain fine exhaust level. In addition, the charcoal Canister Purge is employed in vaporized exhaust.

※ **Improvement of engine**

Middle spark plug ,semicircular combustion chamber and improvement of compression ratio , ignition time , such improvement in exhaust system alone has achieved high intake and exhaust efficiency which enables increase of combustion efficiency.

※ **Air induction device**

Introduce the air into the vent-pipe so that the CO and HC incomplete combustion could be turned into innocuous gas in the second reaction.

Difference	Device	Constituting part	Objective and function
Exhaust system	Catalyst device	Catalyst converter	Canned oxygenation catalyst installed in the center of the vent pipe enables the oxygenation of CO, HC and NOX.

—Adjustable parameters and suggested set value

·Idle adjustment- engine speed  $1750 \pm 100$ rpm/min

CO concentration 0.5-1.0%

## 17.4 Catalyst converter system

### 17.4.1 Structure :

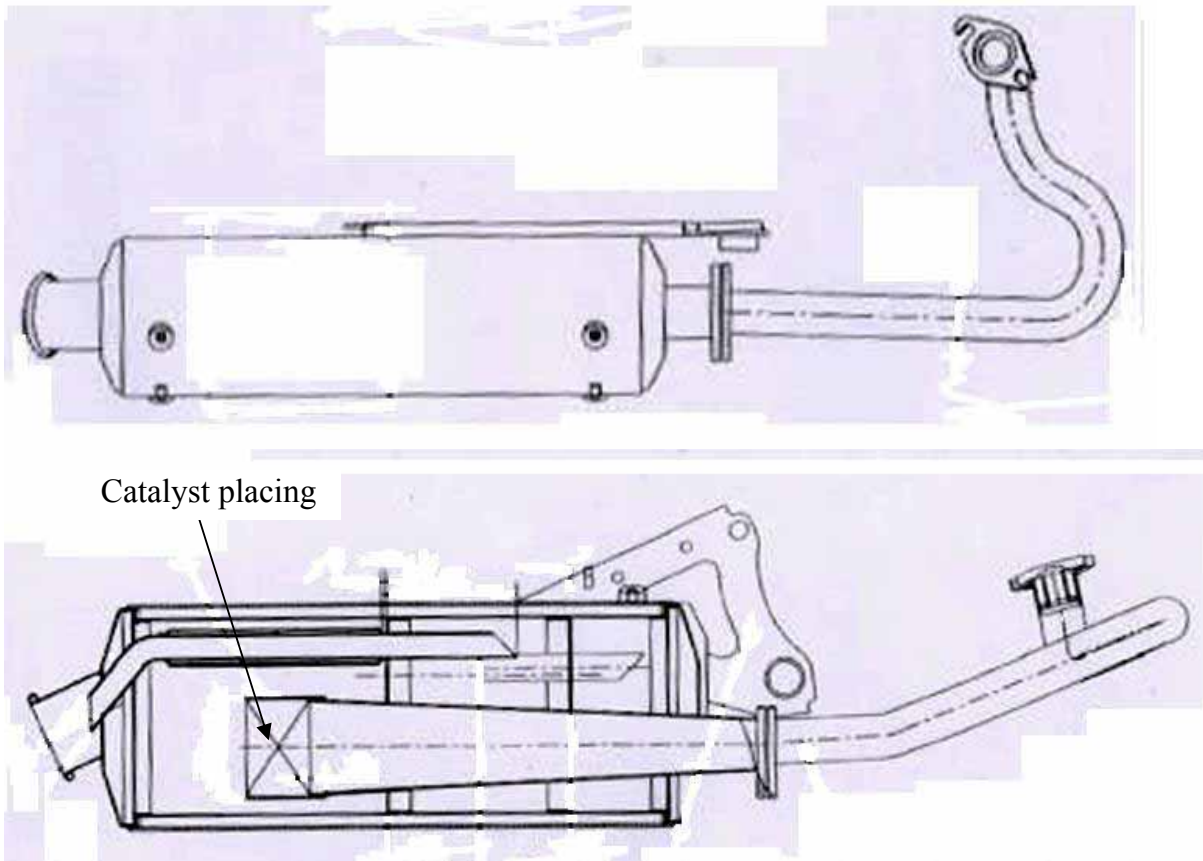

### 17.4.2 Description

1. The function of the converter catalyst is to convert HC, CO and  $\text{NO}_x$  after incomplete combustion into innocuous gas such as  $\text{H}_2\text{O}$ ,  $\text{CO}_2$ , and  $\text{N}_2$  then discharge them out.

2. The converter catalyst contains rare metal like platinum and rhodium and only unleaded gasoline can be used.

□ Note that leaded gasoline will invalidate the catalyst.

• **Matters needing attention in overhaul of vehicles ( vent pipes ) loaded with catalyst converter:**

1) For Keep the vehicles loaded with catalyst converter away from inflammable materials. , the engine is too hot to be touched shortly after it is started or stalled.

2) Keep the vehicles loaded with catalyst converter away from inflammable materials.

3) The vent pipe contains CO that does harm to health, therefore don't run the engine in enclosed space.

4) The vehicle loaded with catalyst converter can not use leaded gasoline. ( To guard against catalyst poisoning

5) do not start the engine by pushing the vehicle. If startup must be done by pushing, wait until the temperature of engine and catalyst converter drops.

6) Do not shift up or stall when descending.

7) Do not drive vehicle with bad ignition.

8) Do not repair the engine ignition system by dismantling the spark plug and starting the engine to inspect whether the spark plug is sparkless. If such operation is necessary, it cannot be performed for a long time.

## 17.5 Countermeasure of idle speed emission exceeding specified value ( Two-stroke )

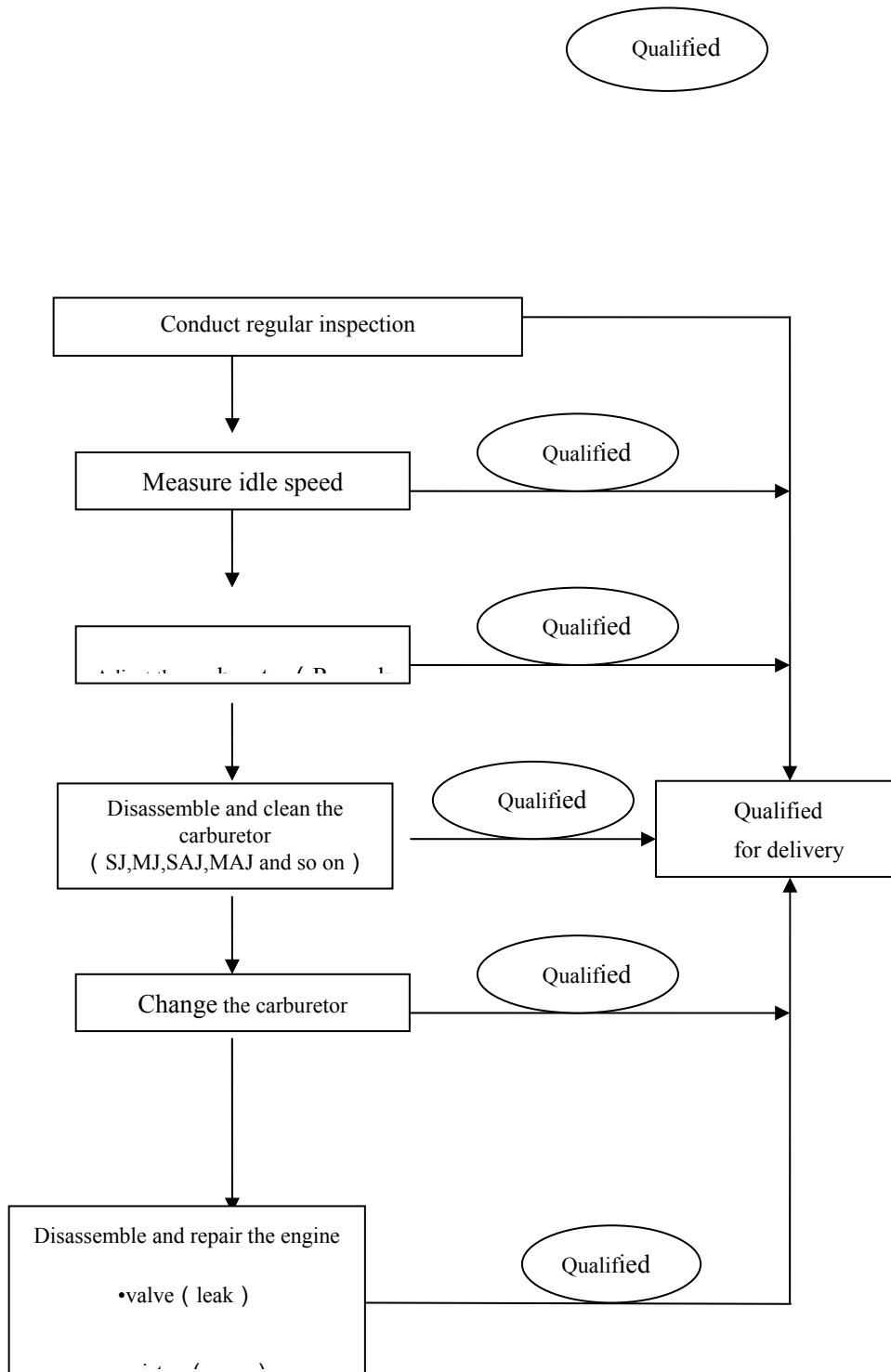

Remark 1: Measure with idle speed measuring procedure.

Remark 2: Adjust the engine speed within the stipulation with a set screw and measure idle speed CO/HC.



## 50T-21R ELECTRICITY PRINCIPLE DIAGRAM

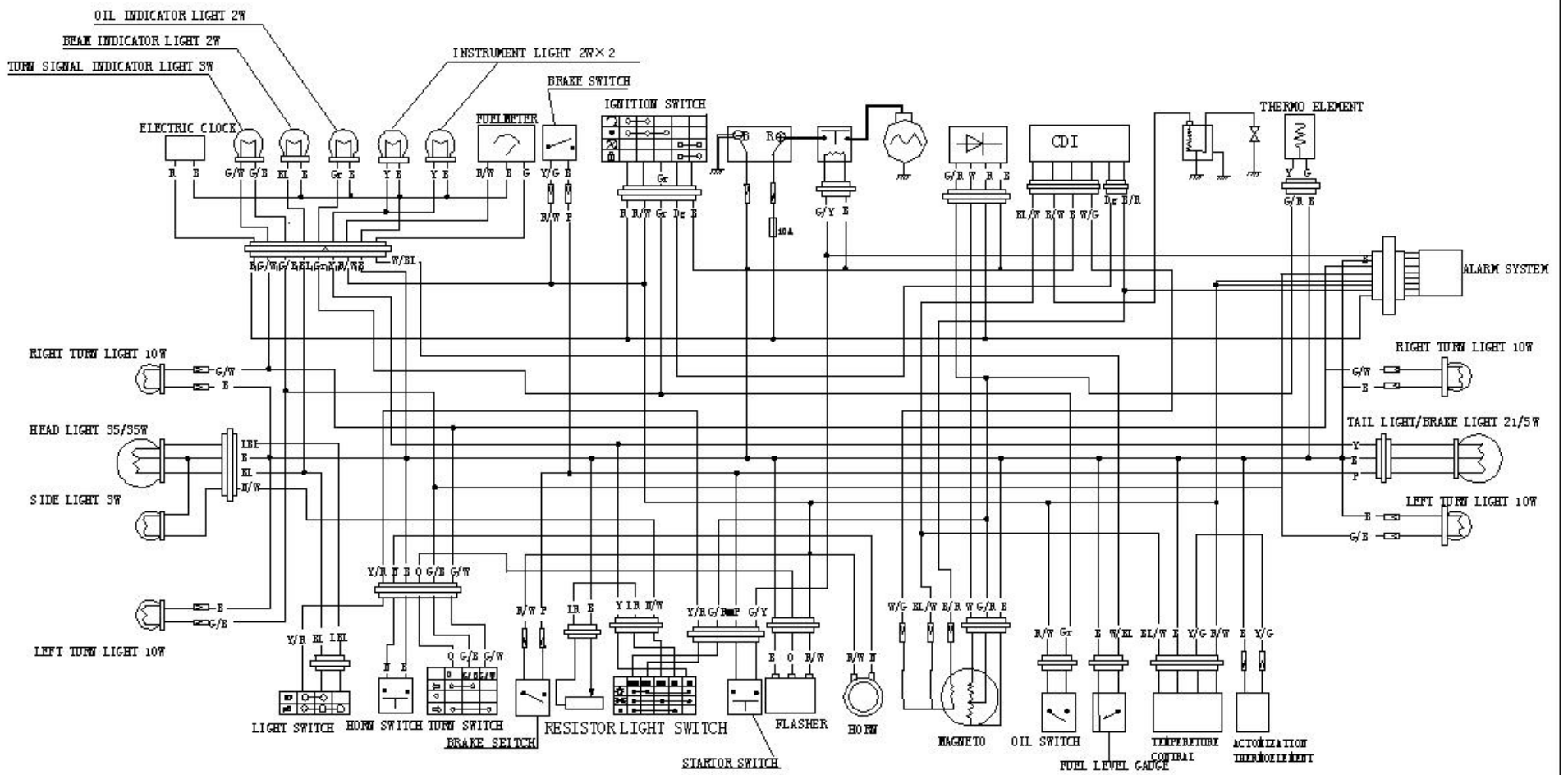

SYMBOL	B	R	W	BL	G	O	Y	P	N	LBL	Dg	C/Y	G/W	G/B	G/R	R/W	W/BL	B/W	N/W	Y/G
COLOR	BLACK	RED	WHITE	BLUE	GREEN	ORANGE	YELLOW	PURPLE	BROWN	LIGHT BLUE	DARK GREEN	GREEN YELLOW	GREEN WHITE	GREEN BLACK	GREEN RED	RED WHITE	WHITE BLUE	BLACK WHITE	BROWN WHITE	YELLOW GREEN